

TRMT8E

1/8th Scale Monster Truck

Instruction Manual

MAN-TRMT8E-2016.3.07



To ensure that you are using the most recent version of this manual:
www.redcatracing.com/manuals/TRMT8EMANUAL.pdf





WARNING!

AGE WARNING!

- ▶ This radio controlled (RC) vehicle is not a toy! You must be 14 years of age or older to operate this vehicle. Adult supervision is required.

RISK OF RUNAWAY VEHICLE OR INJURY!

- ▶ Never turn on the vehicle or plug in the battery pack without first having the controller turned on.

RISK OF FIRE!

RISK OF EXPLOSION!

- ▶ There is a risk of fire and explosion when dealing with batteries. Rechargeable batteries may become hot and catch fire if left unattended or charged too quickly.
- ▶ Use extra caution when charging LiPO batteries. Use only LiPO specific chargers. Use a LiPO safe charging pouch when charging LiPOs. Charge away from flammable materials.
- ▶ Never charge at a rate higher than 1 C. (2000Mah pack= 2amps charge rate). Overcharging can lead to fire and explosion. Always store battery packs in a cool dry place.
- ▶ Never leave the battery plugged into the ESC when the vehicle is not in use.
- ▶ Never connect two batteries to one another.

RISK OF BURNS!

- ▶ The batteries, electronic speed controller (ESC), electric motor, and other areas of the vehicle can get hot. Burns can occur if touched after vehicle operation.
- ▶ Allow adequate time to cool before handling.

RISK OF ELECTRICAL SHOCK!

- ▶ Use caution when charging batteries. Do not touch positive and negative leads together.
- ▶ Do not lay battery on metal. Use only chargers specified for the battery type being charged.
- ▶ Keep batteries and chargers away from water.

RISK OF INJURY!

- ▶ Hobby grade RC vehicles can cause serious injury or death if not operated correctly.
- ▶ Never use vehicle in crowds. Never chase people or animals. Only drive in safe open areas.
- ▶ Keep body parts away from moving parts.

RISK OF DAMAGE!

- ▶ Never operate RC vehicles on public roads. Damage of vehicle and property can occur. Only operate on open private property.
- ▶ Never charge the battery pack while it is still plugged into the RC vehicle. Always unplug the battery pack from the electronic speed controller (ESC) and remove the battery from the RC vehicle before charging. Failure to do so will result in damage to the vehicle's electronics and void the electronics warranty.

RISK OF RUNAWAY VEHICLE OR INJURY AND DAMAGE!

- ▶ Do not mix old and new batteries. Do not mix alkaline, lithium, standard (carbon zinc), or rechargeable (nickel cadmium) batteries. Do not charge or charge batteries in a hazardous location. Only use new AA batteries in your radio transmitter. Replace transmitter batteries often to ensure full control of the vehicle.
- ▶ Perform a radio range check BEFORE running your RC vehicle to avoid a runaway vehicle.

FCC COMPLIANCE STATEMENT!

- ▶ The radio included with your vehicle complies with part 15 of the FCC Rules.

Operation is subject to the following two conditions:

- (1) This device may not cause harmful interference, and
- (2) This device must accept any interference received, including interference that may cause undesired operations.

Note: This equipment has been tested and found to comply with the limits for a Class B digital device, pursuant to Part 15 of the FCC Rules. These limits are designed to provide reasonable protection against harmful interference in a residential installation. This equipment generates, uses and can radiate radio frequency energy and, if not installed and used in accordance with the instructions, may cause harmful interference to radio communications. However, there is no guarantee that interference will not occur in a particular installation. If this equipment does cause harmful interference to radio or television reception, which can be determined by turning the equipment off and on, the user is encouraged to try to correct the interference by one of the following measures: Reorient or relocate the receiving antenna. Increase the separation between the equipment and receiver. Connect the equipment into an outlet on a circuit different from that to which the receiver is connected. Consult the dealer or an experienced radio/TV technician for help.

- ▶ **WARNING:** Any changes or modifications not expressly approved by the party responsible for compliance could void the user's authority to operate this equipment.
- ▶ **WARNING:** While operating the Radio, a separation distance of at least 20 centimeters must be maintained between the radiating antenna and the body of the user or nearby persons in order to meet the FCC RF exposure guidelines.



Perform a radio range check:

- ▶ Install new AA batteries into the bottom of the transmitter.
- ▶ Turn on the transmitter.
- ▶ Turn on the ESC power switch, which is found in the vehicle.
- ▶ Check that the controls are working properly.
- ▶ Keep fingers away from potentially moving parts and hold the vehicle off the ground.
Note: Always turn on the transmitter first to prevent runaways.
- ▶ Check that the controls are working properly. The steering wheel should operate the steering and the trigger should operate the motor. Pulling the trigger should make the vehicle go forward, pushing the trigger should apply the brake and reverse. You may need to adjust the throttle trim found on the transmitter to keep the wheels from spinning while the trigger is in the neutral position.
- ▶ Have a buddy hold the vehicle and walk 50 yards away. You and your buddy should decide on a routine beforehand, since it will be difficult to communicate with each other while testing. An example would be:
 - ▶ Turn the steering wheel left and count to ten
 - ▶ Turn the steering wheel right and count to ten
 - ▶ Pull the trigger and count to ten
 - ▶ Push the brakes and count to ten.
 - ▶ You will want to repeat these steps moving further out as you progress until you are beyond the maximum distance you plan to run the vehicle.
- ▶ If the radio performed without any glitches or twitching at maximum distance, you are ready.

Water Warning:

- ▶ After vehicle gets wet, please unplug the ESC from the battery to avoid putting users in danger. Also, rust proofing the bearings and metal parts is highly recommended.



- ▶ If you feel driving in water is necessary, please seal all holes in the tires and rims before performing this action to prevent the fire foam from absorbing water inside the tires.

TRAXXAS

Adjustable Pillow Balls

Adjustable Pillow Balls

Oil Filled Shocks

Battery Box

ON/OFF Switch

Motor

Oil Filled Shocks

LED Lights

ESC

LED Lights

Oil Filled Shocks

Receiver Box

Steering Servo

Oil Filled Shocks

Battery Box

Adjustable Pillow Balls

Adjustable Pillow Balls



Thank you for choosing the Team Redcat TR-MT8E. The TR-MT8E is designed to be fun to drive and uses top quality parts for performance and durability. Before you start using your new RC kit, we suggest you read through the instruction manual first. Be sure to check all tips before you start. We hope you enjoy your new Team Redcat RC.

Features:

- ▶ Factory assembled
- ▶ Bright LED Lights included
- ▶ Reinforced Differentials
- ▶ Hardened Steel Driveshafts
- ▶ Stylish Body
- ▶ Large Wheels and Tires
- ▶ Rear Wing and Wheelie Bar
- ▶ High Quality Ball Bearings
- ▶ Super Strong, Long Travel Suspension
- ▶ Adjustable Turnbuckles
- ▶ Center Driveshaft Dust Cover

Specifications:

- ▶ 1/8 4WD EP Monster Truck (RTR)
- ▶ Ground Clearance: 88mm
- ▶ Weight: 4980g
- ▶ Length: 560mm
- ▶ Width: 440mm
- ▶ Wheelbase: 350mm
- ▶ Height : 260mm
- ▶ Wheel Track : 440mm
- ▶ High Torque 2500KV Brushless Motor
- ▶ Heavy Duty Waterproof 100A 4S ESC
- ▶ Savox Heavy Duty Waterproof Servo
- ▶ 2.4GHz Radio System



Thank you for purchasing the TR-MT8E. To drive the vehicle, you will need to acquire the following items.

1 Included tools

- Cross Wrench (17mm)

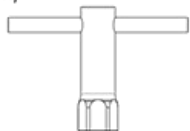

- L Type Hex Wrench (2.5mm) #117031

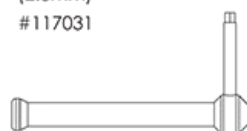

2 Required items

- AA Alkaline Or Rechargeable Batteries For Transmitter, 4pcs



- 2S 7.4v Rechargeable Lipo Battery Pack X 2

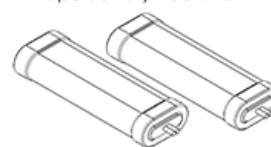

- Battery Pack charger

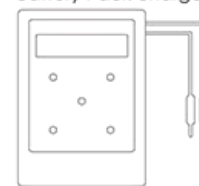

3 Helpful equipment

- Hobby Knife (Warning!! This knife cuts nylon parts and fingers with equal ease. Be careful.)



- Body Scissors (for body cutting) #116006



- Needlenose Pliers



- Hex Wrench Metric Size 1.5mm #117057-1



- Hex Wrench Metric Size 2.0mm #117057-2



- Hex Wrench Metric Size 2.5mm #117057-3



- Hex Wrench Metric Size 3.0mm #117057-4



- Nut Driver 5.5mm (for 3mm nut) #117010



Instruction & Setup Manual

1 Transmitter Function

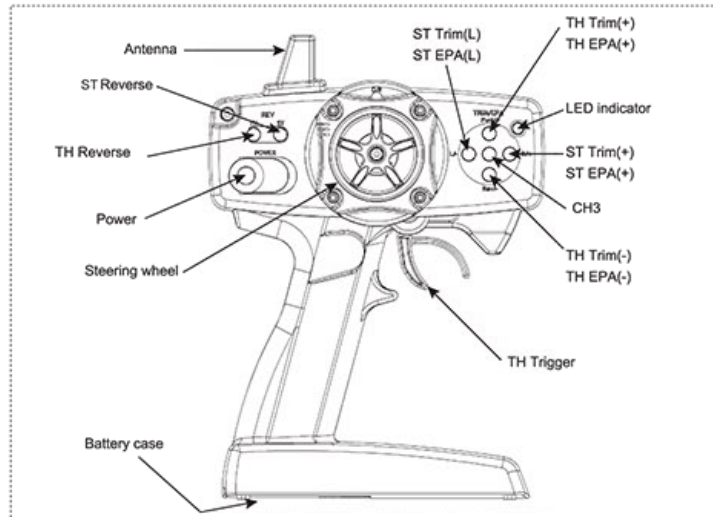

2 Operating Procedure

- 01**
- Install 4pcs AA batteries into the transmitter.
 - Do not mix old and new batteries. Do not mix alkaline batteries, standard (carbon-zinc) or rechargeable (nickel-cadmium) batteries.

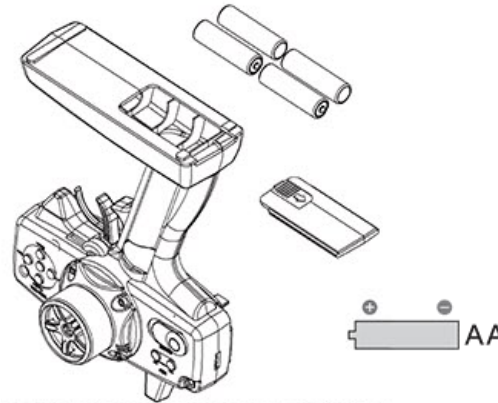

- 02**
- Turn the steering wheel right to steer the front tires right.
 - Turn the steering wheel left to steer the front tires left.



- 03**
- Pull the throttle trigger to move the vehicle forward.
 - Push the throttle trigger forward to brake and reverse the vehicle.



3 Binding (connecting the receiver to transmitter)

Binding the Receiver to the Transmitter

"Binding" is tuning the receiver to the frequencies used by the transmitter. Bind the receiver to the transmitter as follows:

1. With both transmitter and receiver turned off, place the units no more than 30 cm (1 ft) apart.
2. While holding down the receiver's BIND button, power on the ESC. The receiver's LED will start to flash steadily, indicating that the unit is in binding mode, a state that lasts up to 30 seconds.
3. Turn the transmitter on. It will immediately go into binding mode, a state that lasts one second.
4. When the receiver's LED shines steadily, binding is complete.

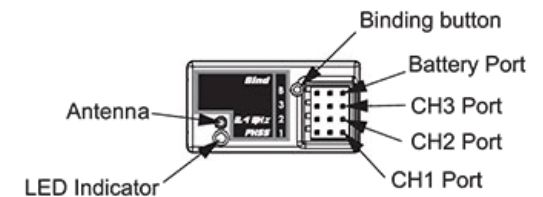



ESC Features

- ▶ Completely water-proof and dust-proof.
(Please remove the cooling fan when running car in water, and after running, please clean and then dry the ESC to avoid the oxidation of copper connectors)
- ▶ The built-in switching mode BEC has powerful output to supply all electronic equipment.
- ▶ Proportional ABS brake function with 5 steps of maximum brake force adjustment and 8 steps of drag-brake force adjustment. Also compatible with the mechanical disc-brake system.
- ▶ Multiple protection features: Low voltage cut-off protection / Over-heat protection / Throttle signal loss protection / Motor blocked protection
- ▶ Easily programmed with the SET button of the ESC.

ESC Specifications

Model	WP-S8A-RTR
Cont./Burst Current	100A/650A
Motor Supported	Sensorless brushless motors
Cars Applicable	1/8 SCT/Buggy/Truggy/Truck
Motor Limit	2S Lipo: KV≤6000 3S Lipo: KV≤4000 4S Lipo: KV≤2600
Resistance	0.0005 ohm
Battery	6-12 cells NiMH 2-4S Lipo
BEC Output	<i>Note1</i> 6V/3A Switch mode
Dimensions	59.5(L) x 48(W) x 42(H)
Weight (With Wires)	173g

NOTE 1: The cooling fans of ESC is supplied by the built-in BEC, so it is always working under 6V.

ESC Connections

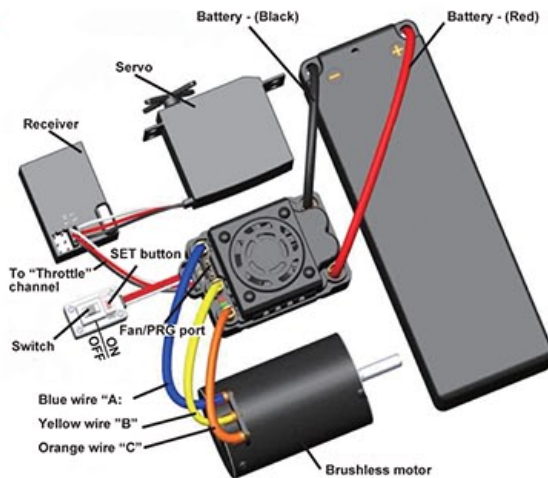

Using your ESC

WARNING! For safety, please keep the wheels from contacting anything when switching on the ESC.

1. Connect The ESC, Motor, Receiver, Battery And Servo

The #A, #B, #C wires of the ESC can be connected with the motor wires freely (without any sequence). If the motor runs in the opposite direction, please swap any two wire connections.

2. Throttle Range Setting (Throttle Range Calibration)

To make the ESC match the throttle range of the controller, you must calibrate it when you begin to use a new ESC or a new transmitter.

The following pictures show how to set the throttle range.

- A) Switch off the ESC, turn on the transmitter.
B) Hold the "SET" key and then switch on the ESC. Release the "SET" key as soon as possible when the red LED begins to flash. (*Note2*)

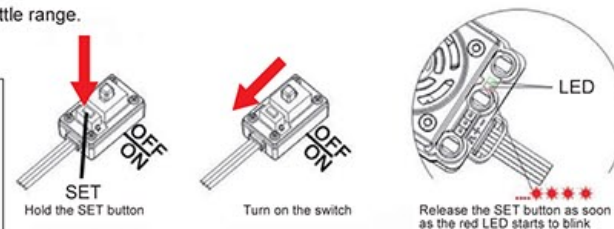

Note2: If you don't release the "SET" key as soon as the red LED begins to flash, the ESC will enter the program mode, in such a case, please switch off the ESC and re-calibrate the throttle range again from step A to step 0.

- C) Set the 3 points according to the steps shown in the pictures on the right side.

- 1) The neutral point**
While leaving the trigger in neutral position, click the SET key, the green LED flashes 1 time.
 - 2) The end point of forward direction**
While holding the trigger in the full throttle position, click the SET key, the green LED flashes 2 times.
 - 3) The end point of backward direction**
While holding the trigger in the full brake/reverse position, click the SET key, the green LED flashes 3 times.
- D) Throttle range is calibrated; motor can be started after 3 seconds.

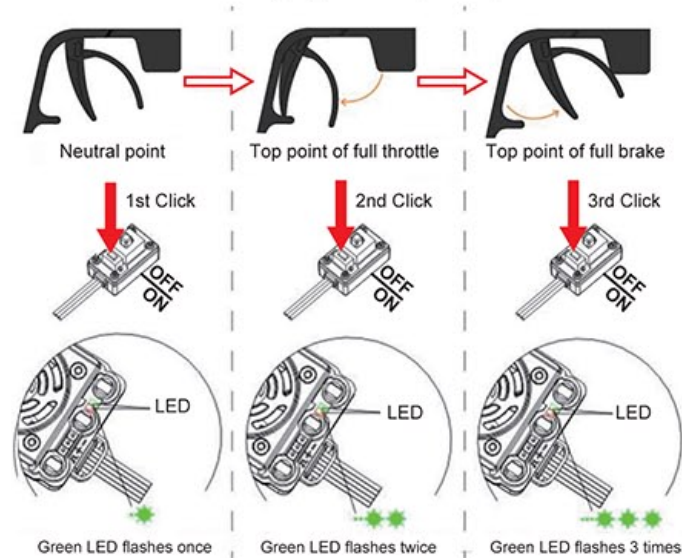

3. Check LED Status In Normal Running

- ▶ Normally, if the throttle trigger is located in the neutral range, neither the red LED nor the green LED lights.
- ▶ The red LED lights when the car is running forward or backward and it will flash quickly when the car is braking.
- ▶ The green LED lights when the throttle trigger is moved to the full brake position.

Programmable Items List

(The *italics* text in the following form are the default settings)

Programmable Items	Programmable Value								
	1	2	3	4	5	6	7	8	9
1. Running Mode	Forward with Brake	<i>Forward / Reverse with Brake</i>	Forward and Reverse						
2. Drag Brake Force	0%	5%	10%	20%	40%	60%	80%	100%	
3. Low Voltage Cut-Off Threshold	Non-Protection	2.6V / Cell	2.8V / Cell	<i>3.0V / Cell</i>	3.2V / Cell	3.4V / Cell			
4. Start Mode(Punch)	Level 1	Level 2	Level 3	Level 4	<i>Level 5</i>	Level 6	Level 7	Level 8	Level 9
5. Max Brake Force	25%	<i>50%</i>	75%	100%	Disable				

1. Programmable Values

1.1. Running Mode: In "Forward with Brake" mode, the car can go forward and brake, but cannot go backward, this mode is suitable for competition; "Forward/reverse with Brake" mode provides the backward function, which is suitable for daily driving.

Note: "Forward/Reverse with Brake" mode uses "Double-click" method to make the car go backward. When you move the throttle trigger from forward zone to backward zone for the first time (The 1st "click"), the ESC begins to brake the motor, the motor speeds down but it is still running, not completely stopped, so the backward action is NOT activated immediately. When the throttle trigger is moved to the backward zone again (The 2nd "click"), if the motor speed is slowed down to zero (i.e. stopped), the backward action will happen. The "Double-Click" method can prevent mistakenly reversing when the brake function is frequently used in steering. Be aware, while using reverse, the motor will go immediately forward when the trigger is pulled. It is recommended to allow the vehicle to come to a complete stop from reverse before applying forward throttle.

"Forward/Reverse" mode uses "Single-click" to make the car go backward. When you move the throttle stick from forward zone to backward zone, the car will go backward immediately. This mode is usually used for the Rock Crawler and not for any buggy, truggy, or truck.

1.2. Drag Brake Force: Set the amount of drag brake applied at neutral throttle to simulate the slight braking effect of a neutral brushed motor while coasting.

1.3. Low Voltage Cut-Off: The function prevents the lithium battery pack from over discharging. The ESC detects the battery's voltage at any time, if the voltage is lower than the threshold for 2 seconds, the output power will be cut off, and the red LED flashes in such a way: "tr-tr-, tr-tr-, tr-tr-".

1.4. Start Mode (Also called "Punch"): Select from "Level-1" to "Level-9" as you like. Level-1 has a very soft start effect, while level-9 has a very aggressive start effect. From Level-1 to Level-9, the start force is increased. Please note that if you choose "Level-7" to "Level-9" mode, you must use good quality battery with powerful discharge capability, otherwise these modes cannot get the burst start effect as you want. If the motor cannot run smoothly (that means the motor is cogging), it may be caused by the weak discharge rate of the battery, please choose a stronger battery or a softer gear ratio.

1.5. Maximum Brake Force: The ESC provides proportional brake function. Brake force is related to the position of the throttle trigger. Maximum brake force refers to the force when the throttle trigger is located at the end point of the backward zone. A very large brake force can shorten the brake time, but it may damage the drive train. The "Disable" option inhibits the inherent brake function of the speed controller. When this option is selected, the brake function is realized by a traditional mechanical disc-brake system driven by a servo (optional).

2. Reset All Items To Default Values

At any time when the throttle is located in neutral zone (except in the throttle calibration or parameters program process)

Trouble	Possible Reason	Solution
After power on, motor doesn't work, and the cooling fan doesn't work	The connections between battery pack and ESC are not correct	Check the power connections Replace the connectors
After power on, motor can't work, but emits "beep-beep-, beep-beep-" alert tone. (Every "beep-beep-" has a time interval of 1 second)	Input voltage is abnormal, too high or too low	Check the voltage of the battery pack
After power on, red LED always lights, the motor doesn't work	Throttle signal is abnormal	Plug the control wire into the throttle channel of the receiver correctly.
The motor runs in the opposite direction when it is accelerated	The wire connections between ESC and the motor are not correct	Swap any two wire connections between the ESC and the motor.
The motor suddenly stops running while in working state	The throttle signal is lost	Check the transmitter and the receiver Check the signal wire from the throttle channel of your receiver
	The ESC has entered the Low Voltage Protection Mode or Over-heat Protection Mode	Red LED flashing means Low Voltage. Green LED flashing means Over-heat
When accelerating quickly, the motor stops or trembles	1) The battery has a bad discharge performance 2) Gear ratio is too aggressive 3) The "Start Mode (Punch)" of the ESC is too aggressive	1) Use a better battery 2) Use lower KV motor or softer gear ratio 3) Set the "Start Mode (Punch)" to a softer value
When the throttle stick is in the neutral range, the red LED and the green LED flashes synchronously	Over current protection, motor demagnetization, or motor is over load	1) Reduce the load (Use softer gear ratio or reduce the input voltage) 2) Change the motor
Cannot connected with the LED Program Card or LCD Program Box	Mistakenly uses the Rx wire to connect to the program card/box.	Connect the program card/box to the special programming port of the ESC, don't use the Rx wire.

Hold the "SET" key for over 3 seconds, the red LED and green LED will flash at the same time, which means each programmable item has been reset to its default value.

Program the ESC:

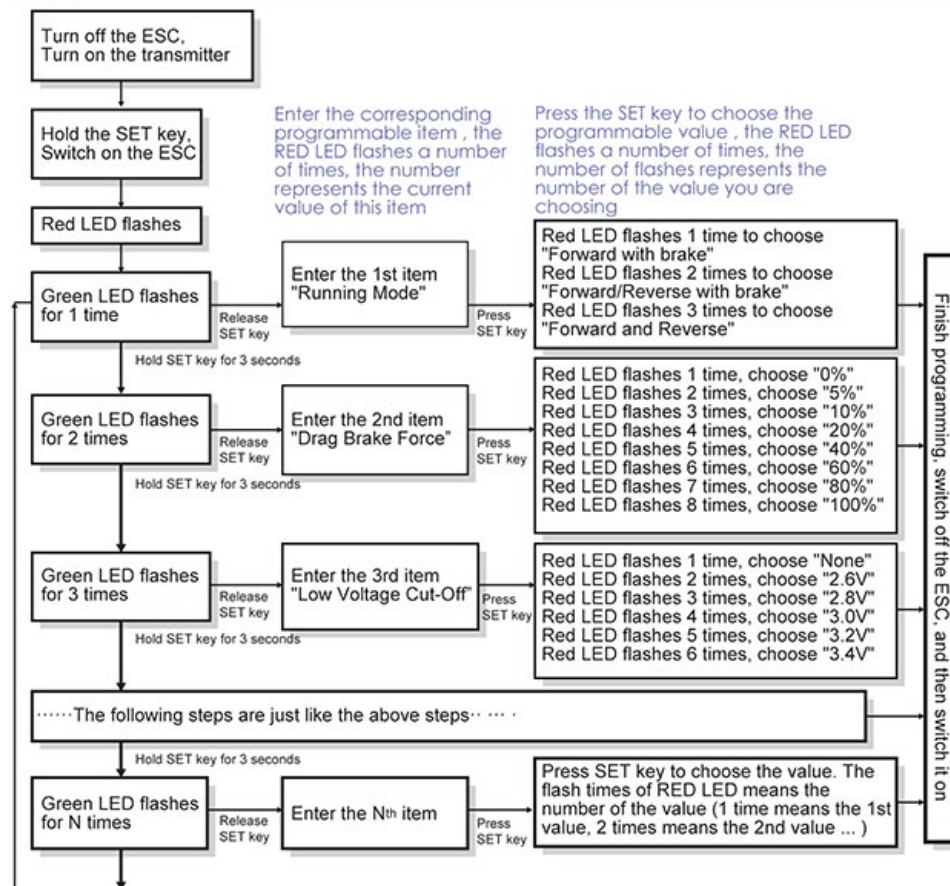

Note:

- In the program process, the motor will emit "Beep" tones while the LED, on the ESC, is flashing.
- ... A long constant flash (ESC) and long "Beep" tone (motor) represents the number "5". add the following short beeps to "5" to get the whole number. Here are some examples:
 "A long solid flash" (& Motor sounds "B---") = the No. 5 item
 "A long solid flash + a short flash" (Motor sounds "B---,B") = the No. 6 item (5+1=6)
 "A long solid flash + 2 short flashes" (Motor sounds "B---,B,B") = the No. 7 item (5+2=7)
 "A long solid flash + 3 short flashes" (Motor sounds "B---,B,B,B") = the No. 8 item (5+3=8)
 "A long solid flash + 4 short flashes" (Motor sounds "B---,B,B,B,B") = the No. 9 item (5+4=9)

2. Program the ESC with the LED program box (Optional equipment)

Note3: The Rx wire of the ESC (for connecting receiver) CANNOT be used to connect with the LED Program Card. Only use the special port between the terminals ABC to connect to the Program Card.

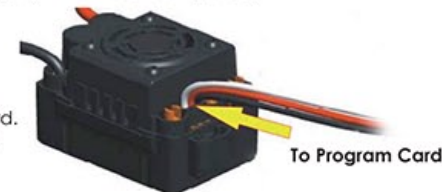



Exploded view

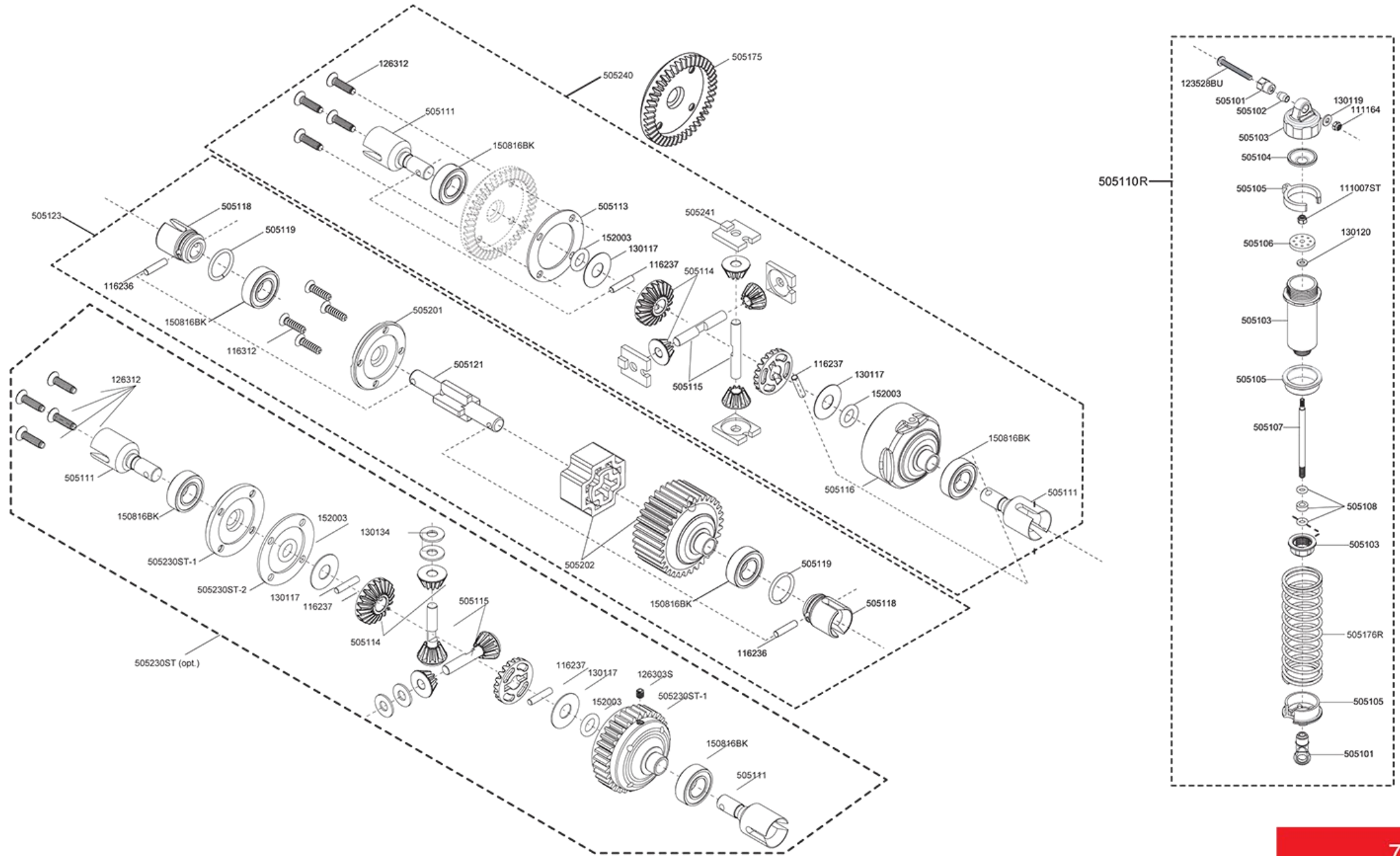

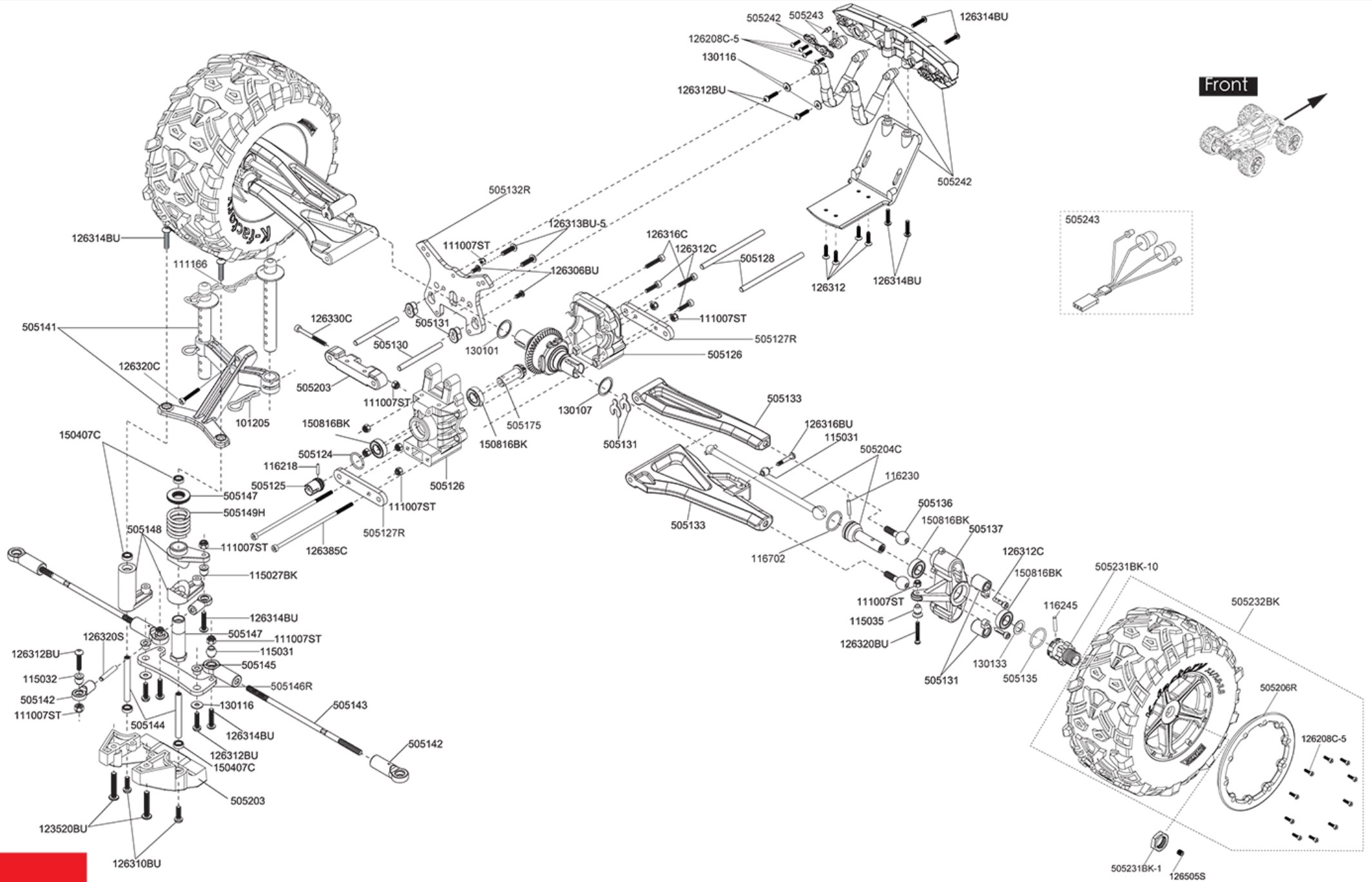



Exploded view (chassis)

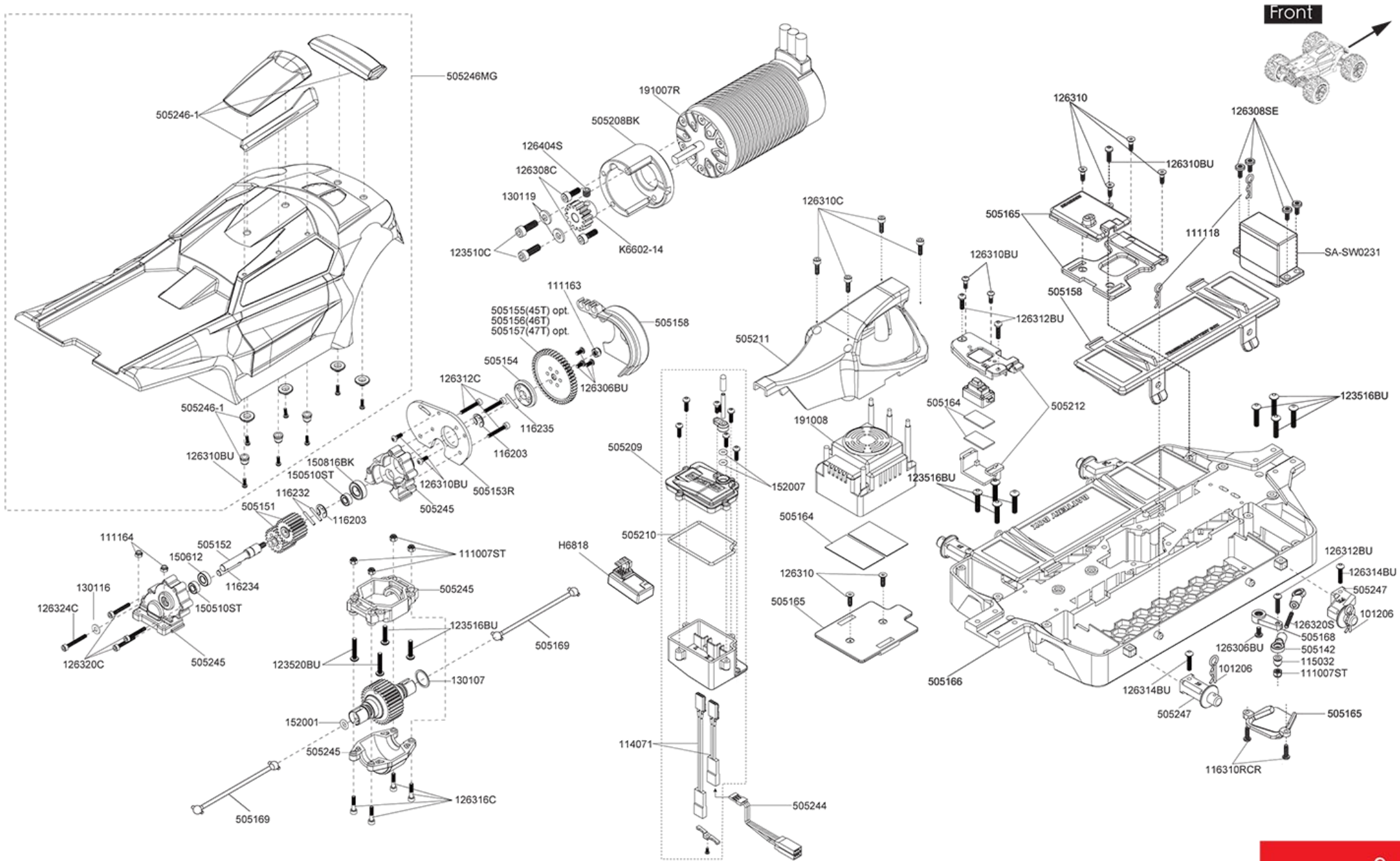

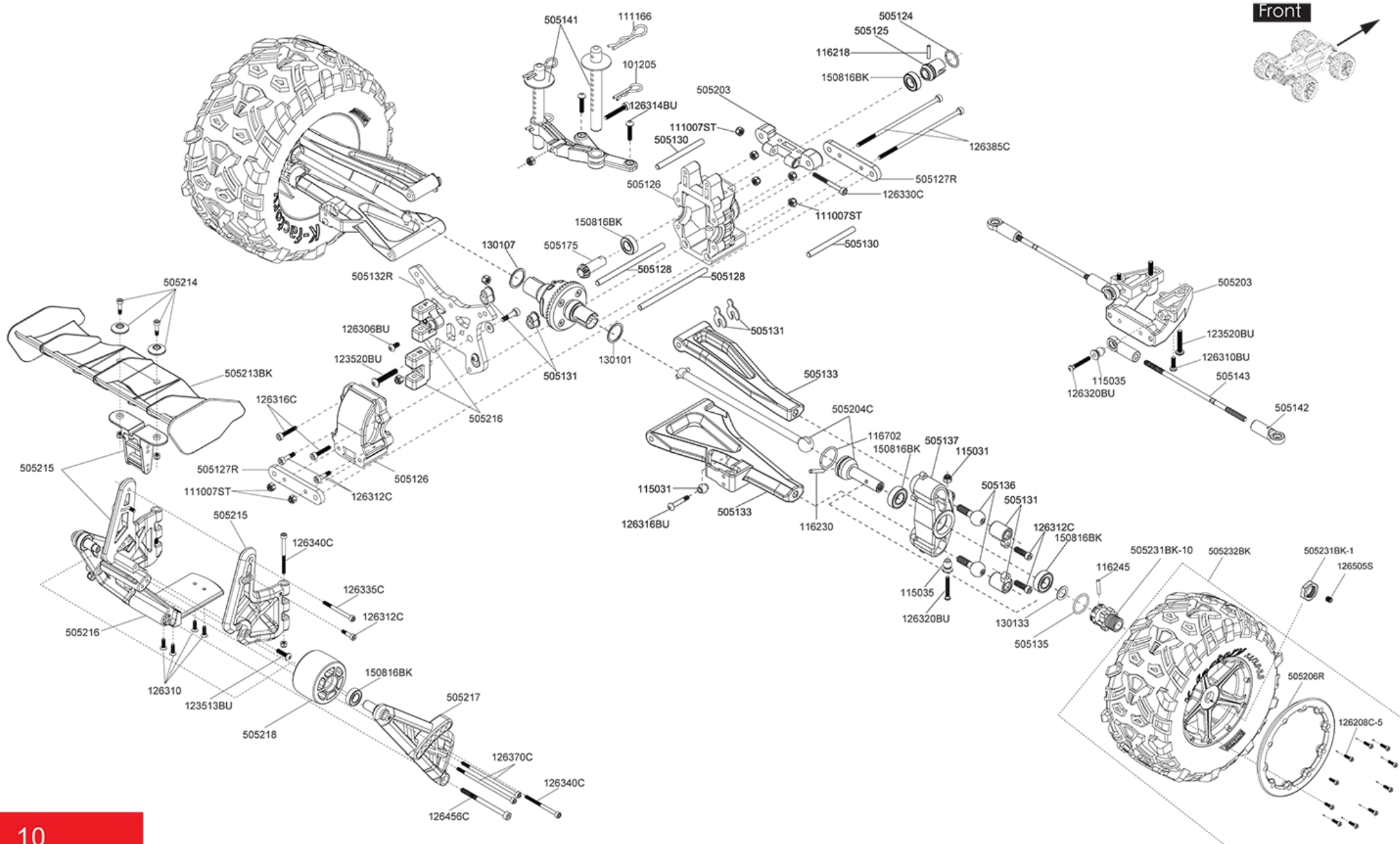



Parts	
Item No.	Item Description
101205	R Clip R8 (10)
101206	R Clip R8 (10)
111007ST	3mm Steel Locknut (10)
111118	R5 R-clip (10)
111163	4mm Lock Nut (10)
111164	3.5mm Lock Nut (10)
111166	R8 Angled Body Clip (10)
114071	Singal Extension Cord (2)
115027BK	Ball End & 5.8mm Single Flanged Steel Ball (6) Black
115031	6.8mm Flanged Steel Ball (10)
115032	5.8mm Single Flanged Steel Ball (6)
115035	6.8mm Single Flanged Steel Ball (6)
116203	E-clip 5 (10)
116218	2.5x12.8mm Pin (10)
116230	2.5x15.8mm Pin (10)
116232	2x13.8mm Pin (10)
116234	5x23.9mm Pin (10)
116235	2x14.8mm Pin (10)
116236	2.5x10.8mm Pin (10)
116237	2.5x11.8mm Pin (10)
116245	2.5x13.8mm Pin (10)
116310RCR	3x10mm Steel RH TP Screw (cross) (6)
116312	3x12mm Steel F.H. Self-Tapping Screw (6)
116702	C-17 Clip (6)
123510C	3.5x10mm Steel Cap Screw (6)
123513BU	3.5x13mm Steel Button Head Screw (6)
123516BU	3.5x16mm Steel BH Screw (6)
123520BU	3.5x20mm Steel BH Screw (6)
123528BU	3.5x28mm Steel BH Screw (6)
126208C-5	2.5x8mm Steel Cap Screw (6)
126303S	3x3mm Set Screw (6)
126306BU	3x6mm Steel Button Head Screw (6)
126308C	3x8mm Steel Cap Screw (6)
126308SE	3x8mm Steel Flat Round Servo Mount Screw (6)
126310	3x10mm Steel F.H. Screw (6)
126310BU	3x10mm Button Head Screw (6)
126310C	3x10mm Cap Screw (6)
126312	3x12mm Steel F.H. Screw (6)
126312BU	3x12mm Button Head Screw (6)
126312C	3x12mm Cap Screw (6)
126313BU-5	3.5x13mm Steel Button Head Screw (6)
126314BU	3x14mm Button Head Screw (6)
126316BU	M3X16mm BH Screw(10)

Parts	
Item No.	Item Description
126316C	3x16mm Cap Screw (6)
126320BU	3x20mm Steel Button Head Screw (6)
126320C	3x20mm Cap Screw (6)
126320S	3x20m Set Screw (6)
126324C	3x24mm Cap Screw (6)
126330C	3x30mm Cap Screw (6)
126335C	3x35mm Cap Screw (6)
126340C	3x40mm Cap Screw (6)
126370C	3x70mm Cap Screw (6)
126385C	3x85mm Cap Screw (6)
126404S	4x4mm Set Screw (6)
126456C	4x56mm Cap Screw (6)
126505S	M5x5mm Set Screw(6)
130101	13.2x15.9x0.2mm Shim (6)
130107	13.2x15.9x0.5mm Shim (6)
130116	3.2x8x0.7 Washer (10)
130117	6.2x15x0.3 Washer (10)
130119	3.6x8x1mm Washer (10)
130120	3x7x1mm Washer (10)
130133	8.1x12x0.5mm Shim (10)
130134	4.2x9.6x0.7mm Washer (10)
150407C	4X7X2.5mm Collar(4)
150510ST	5x10x4mm Steel Bearing (4)
150612	6x12x4mm Bearing (4)
150816BK	8x16x5mm Bearing-Black
152001	O-RING P5(10)
152003	O-RING P6(10)
152007	O-Ring P3(10)
191007R	Brushless Motor 2500KV (14.8V)
191008	WP-8100 ESC for Brushless Motor (14.8V)
505101	Shock Pivot Ball Mount (4)
505102	Shock Pivot Ball (4)
505103	Shock Body (2)
505104	Shock Bladder 17mm (4)
505105	Shock Spring Holder
505106	Shock Piston
505107	Shock Shaft (2)
505108	Shock O-Ring & Washer
505110R	Shock Absorber Set
505111	F/R Differential Outdrive (2)
505113	Differential Case Gasket (4)
505114	Differential Bevel Gear Set (for 1 diff)
505115	Differential Bevel Shaft (2)

Parts	
Item No.	Item Description
505116	Bevel Gear Case
505118	Center Solid Axle Outdriver (2)
505119	C-Clip 10.8x1.1mm (4)
505121	Center Solid Axle
505123	Complete Center Spool Kit
505124	C-Clip 13x1.3mm (4)
505125	Center Joints Outdriver (2)
505126	Differential Box
505127R	Lower Arm Mount-Red (2)
505128	Lower Arm Hinge Pin 4x70mm (2)
505130	Upper Arm Hinge Pin 4x48mm (2)
505131	Nylon Adjuster & Pivot Ball Mount
505132R	Shock Tower-Red
505133	Arm Set
505135	C-Clip 15x1.3mm (4)
505136	Pivot Ball (11mm) (4)
505137	Steering Block (2)
505141	Body Post Set (F/R)
505142	Ball Cup 5.8mm (10)
505143	4x110mm Rod (2)
505144	Servo Saver Inner Post
505145	Steering Bushing
505146R	Steering Linkage Plate-Red
505147	Servo Saver Post
505148	Servo Saver Nylon Parts
505149H	Servo Saver Spring(Hard)
505151	Reduction Gears
505152	Spur Gear Shaft
505153R	Motor Mount Plate-Red
505154	Spur Gear Hub
505158	Spur Gear, Battery , Driveshafts Cover
505164	Double Side Tape
505165	ESC&Motor Mount , Front Nylon Cover
505166	Chassis
505168	Alum. Servo Arm
505169	Center Universal Joint
505175	Machined Bevel Gear -36T/11T
505176R	Shock Spring K=1.6-Red (2)
505201	Center Gear Cover (for 3mm screws)
505202	Center Gear (33T) (for 3mm screw)
505203	Front/Rear Upper Arm Hinge Pin Mount (4)
505204C	New Universal Driveshaft (2)(C Clip ver.)
505206R	Tire Ring-Red (2)

Parts	
Item No.	Item Description
505208BK	Motor Mount (for 4S Motor)-Black
505209	Waterproof Receiver Box
505210	Receiver Box Seal (2)
505211	Cover for Waterproof ESC
505212	Waterproof Switch Mount
505213BK	Rear Wing-Black
505214	Screws and Shims for Rear Wing (2)
505215	Rear Wing Support
505216	Rear Wing Support Mount
505217	Wheelie Support (2)
505218	Wheelie Wheel
505230ST	Center Differential Set With Steel Case
505231BK-1	Serrated Wheel Nut (2)- Black
505231BK-10	Alum. Splined Wheel Hubs and Nuts +10mm (2)-Black
505232BK	Mounted Tire 7.1" Size - Splined wheel hubs (2)
505240	Complete FG Differential Set (F/R)
505241	Differential Quadrangle Shim (4)
505242	Size-up Bumper Set
505243	Front LED Light
505244	Extension Cord "Y" Type
505245	Quick-released Central Box
505246-1	Body Upper Protection
505246MG	Body - Metal Gray
505247	Lateral Body Support (2+2)
H6817	HT3GDS 2.4G Transmitter w/Receiver
H6818	HR3GR 3 Channel 2.4G Receiver
K6602-14	M1.0 Pinion Gear for 5mm Shaft 14T
SA-SW0231	SW-0231 Waterproof Servo (15KG)

Accessory Parts	
Item No.	Item Description
HX-580030C-D	LIPO Battery, 5800mAh 30c 7.4V
HX-403	LIPO Battery Charger
505230ST-1	Center Differential Steel Case
505230ST-2	Gasket (for center differential steel case)
505173	Quick Release Battery Holder
505155	Diff. Planetary Gear Shafts (shafts only) (2)
505156	Spur Gear 46T (CNC Machined)

505225T1

CNC Machined Battery Holder (2)-T1



505226T1

CNC Machined Battery Holder Mount (2)-T1



505224T1

The Fifth Wheel Multi-Angle Adjusting Mount-T1



505176R

Shock Spring K=1.6 (Red) (2)



505103A

Alum. Shock Body (2)



505227T1

Alum. Body Post (2)-T1

505227ST

Steel Body Post (2)



5052146T1

Alum. Shims for Rear Wing (2)-T1



505223T1

CNC Machined Alum. Lower Arm (2)-T1



505221T1

6.3mm CNC Machined Alum. Shock Tower (F/R)-T1



505222T1

CNC Machined Alum. Upper Arm (2)-T1



505228 (FRONT) 505229 (REAR)

CNC Machined Stainless Chassis Guard



505231BK -0 / -10 / -15

Alum. Splined Wheel Hubs and Nuts (2)-Black



505220

Steel Shock Pivot Ball Mount (2)



505245

Quick-Release Center Diff. Box



5051185T

Steel Center Solid Axle Outdriver (2)



5052305T

Center Differential Set With Steel Case



505125ST

ST Steel Center Joints Outdriver (2)

505111ST

ST Steel F/R Differential Outdrive (2)



505146T1

Steering Linkage Plate-T1

505127T1

Lower Arm Mount-T1 (2)



Instruction Manual

MAN-TRMT8E-2016.3.07

TRMT8E



To ensure that you are using the most recent version of this manual:
www.redcatracing.com/manuals/TRMT8EMANUAL.pdf