

MODEL: RS10 XT



1/10 SCALE ROCK CRAWLER

ROCKSLIDE RS10 XT OWNERS MANUAL



Fast • Affordable • Fun

MAN-RS10XT-2015.25.08-V4

•To ensure that you are using the most recent version of this manual:

www.redcatracing.com/manuals/RS10XTmanual.pdf

•To ensure that you have the most recent version of the Electronic Vehicles Manual:

www.redcatracing.com/manuals/ELECTRIC-MANUAL.pdf

WARNING

AGE WARNING!

- ▶ This radio controlled (RC) vehicle is not a toy! You must be 14 years of age or older to operate this vehicle. Adult supervision is required.

RISK OF RUNAWAY VEHICLE OR INJURY!

- ▶ Never turn on the vehicle or plug in the battery pack without first having the controller turned on.

RISK OF FIRE!

RISK OF EXPLOSION!

- ▶ There is a risk of fire and explosion when dealing with batteries. Rechargeable batteries may become hot and catch fire if left unattended or charged too quickly.
- ▶ The ESC in this vehicle is not designed to be used with LiPO batteries. An external low voltage cutoff, or LiPO ready ESC is required to run LiPO batteries.
- ▶ Use extra caution when charging LiPO batteries. Use only LiPO specific chargers. Use a LiPO safe charging pouch when charging LiPOs. Charge away from flammable materials.
- ▶ Never charge at a rate higher than 1 C. (2000Mah pack= 2amps charge rate). Overcharging can lead to fire and explosion. Always store battery packs in a cool dry place.
- ▶ Never leave the battery plugged into the ESC when the vehicle is not in use.
- ▶ Never connect two batteries to one another.

RISK OF BURNS!

- ▶ The batteries, electronic speed controller (ESC), electric motor, and other areas of the vehicle can get hot.
- ▶ Burns can occur if touched after vehicle operation. Allow adequate time to cool before handling.

RISK OF ELECTRICAL SHOCK!

- ▶ Use caution when charging batteries. Do not touch positive and negative leads together.
- ▶ Do not lay battery on metal. Use only chargers specified for the battery type being charged.
- ▶ Keep batteries and chargers away from water.

RISK OF INJURY!

- ▶ Hobby grade RC vehicles can cause serious injury or death if not operated correctly.
- ▶ Never use vehicle in crowds. Never chase people or animals. Only drive in safe open areas.
- ▶ Keep body parts away from moving parts.

RISK OF DAMAGE!

- ▶ Never operate RC vehicles on public roads. Damage of vehicle and property can occur. Only operate on open private property.
Be cautious of your surroundings. Do not rock climb on cliffs or areas where you, or the vehicle, could fall and get hurt or damage the vehicle.
- ▶ Never charge the battery pack while it is still plugged into the RC vehicle. Always unplug the battery pack from the electronic speed controller (ESC) and remove the battery from the RC vehicle before charging. Failure to do so will result in damage to the vehicle's electronics and void the electronics warranty.

RISK OF RUNAWAY VEHICLE OR INJURY AND DAMAGE!

- ▶ Only use new AA batteries in your radio transmitter. Replace transmitter batteries often to ensure full control of the vehicle.
- ▶ Do not mix old and new batteries. Do not mix alkaline batteries, standard (carbon-zinc) or rechargeable (nickel-cadmium) batteries.
- ▶ Perform a radio range check BEFORE running your RC vehicle to avoid a runaway vehicle.

1. Before Using The RS10XT

Thank you for purchasing the Redcat Racing RS10XT rock crawler.

The RS10XT is a hobby grade vehicle and is not a toy. Please read the entire manual before attempting to operate this vehicle.

Before running the RS10XT, please look over the entire vehicle to ensure there are no damaged or loose parts. Once the vehicle has been used, we can only assume broken parts are a result of improper use. Be sure to check the vehicle over before use.

2. Technical Data

- Length: 450mm
- Width: 268mm
- Height: 148mm
- Wheelbase: 317mm-320mm (adjustable)
- Motor: Two RC390 motors
- Wheel Dia: 130mm
- Wheel Width: 55mm
- Servo: Two 15kg servos
- Gear Ratio: 1 :38.6 (10T motor pinion used),
1 :48.2 (8T motor pinion used)
- Battery: Ni-MH 7.2v, 1800mAH (stick battery)



This data is subject to change without notice as result of product improvement.

3. Main Features

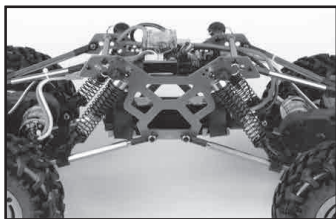

- Aluminum side plates
- Rigid radio plate
- Low C.O.G battery tray
(holds stick battery)

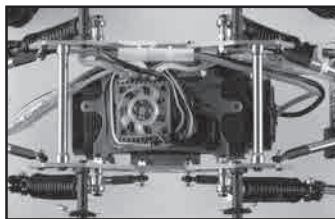

- Computer radio with four
wheel steering.
- Crawler ESC w/ Cooling Fan

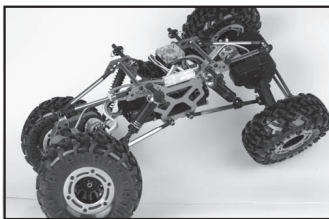

- Lots of articulation enables the
RS10XT to maneuver the
toughest terrain.

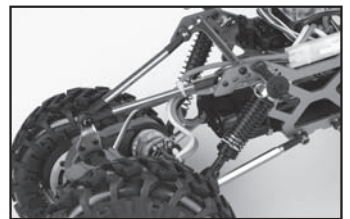

- Updated 4-link suspension
design offers the ultimate in
crawling performance.



- Authentic aluminum bead-lock
rims secure the tires during
hard core off-road use.

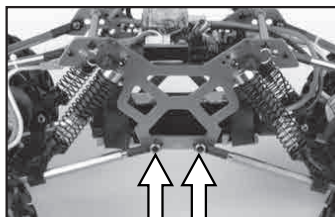

- Adjustable wheel base provides
many setup options. There are
three mounting options on the
lower frame rail.



- Two 15KG Servos perform
reliable steering tasks,
Servo/Motor-on-axle design
puts the weight where you
need it.

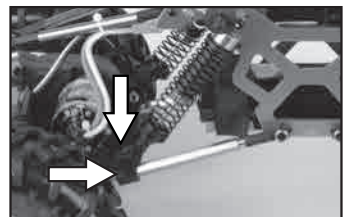

- Shock location can also be
adjusted as desired. Unscrew
the lower mount and adjust it
in or out towards your desired
position.

4. Using the 2.4GHz radio system

General information

- 2.4GHz transmitter and receiver.
- Full functional, computer transmitter, with LCD screen.
- Four steering modes for extreme versatility.
- Always remove batteries from this product when not in use.
- Do not mix old and new batteries. Do not mix alkaline batteries, standard (carbon-zinc) or rechargeable (nickel-cadmium) batteries.



Preparation before using



-Slide out the battery cover to expose the empty battery compartment. Insert four AA size batteries ensuring the (+) side of each battery corresponds with the (+) mark on the battery tray.



-Do not damage or deform the antenna on the transmitter or receiver, this may cause signal loss.

Full functional 2.4GHz transmitter



1	Antenna
2	LCD screen
3	Steering Wheel
4	Steering Trim / Reverse Switch
5	Throttle Trim
6	Power Switch (Slide it to turn on/off)
7	Steering Dual Rate Control Dial (D/R)
8	Trim Switch (for rear wheels)
9	Trigger
10	Steering Mode Switch
11	SEL function button

Full function steering modes

This 2.4GHz transmitter contains various steering modes, which are perfect for the rock crawler.



Press this button to toggle steering modes.

LCD screen on the transmitter

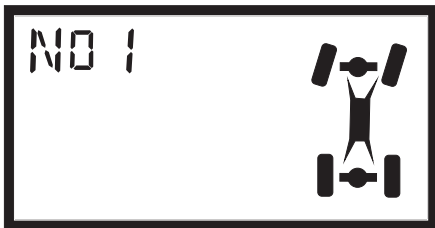

MODE 1

Front wheel steering

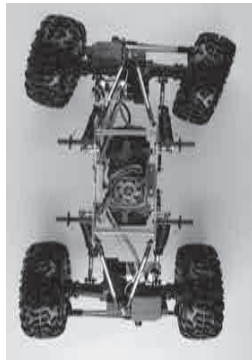

Mode 1 engages front wheel steering only. The rear steering remains straight.

LCD screen on the transmitter

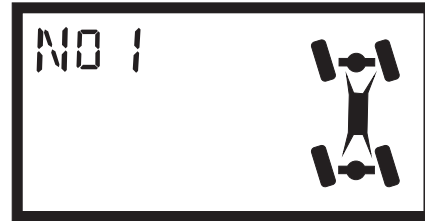

MODE 2

Four wheel steering
- wheels in the same direction

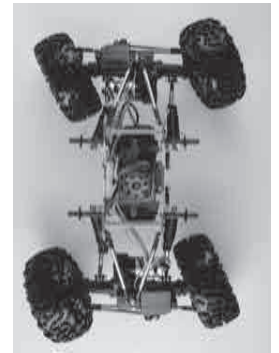

Mode 2 engages front and rear wheel crab steer. Both the front and rear wheels steer in the same direction, allowing the RS10 to drive sideways.

LCD screen on the transmitter

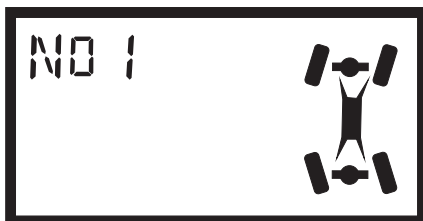

MODE 3

Four wheel steering
- wheels in opposite direction



Mode 3 engages 4-wheel steering. The front and rear wheels steer in the opposite direction, allowing the RS10 to turn in a tight radius.

LCD screen on the transmitter

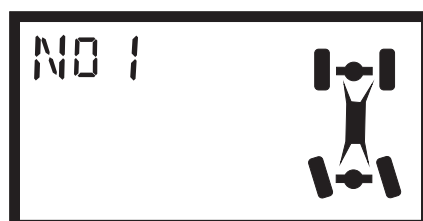

MODE 4

Rear wheel steering

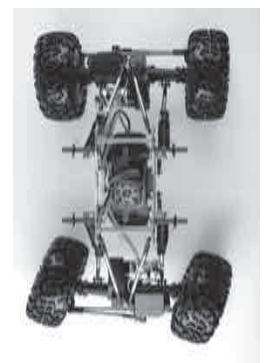

Mode 4 engages rear wheel steering only. The front steering remains straight.

Steering Trim/Steering Reverse Function



LCD screen on the transmitter

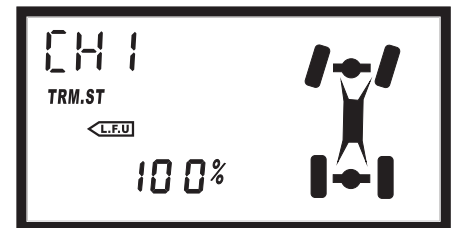
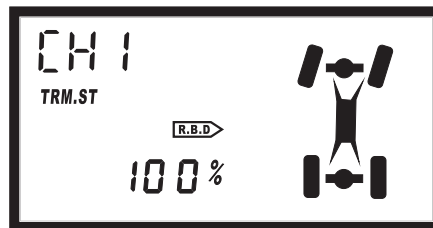

TRM.ST (Steering Trim) range is around 0-100% for both left and right steering on the front wheels.

Toggle this switch to select your desired steering trim volume.

To Reverse Steering:

Press SEL (Select Button) on your radio once, the LCD display appears as Channel 1 (NOR.)

Toggle the SWITCH (Steering Trim /Reverse Switch) to change from NOR to REV as shown below:

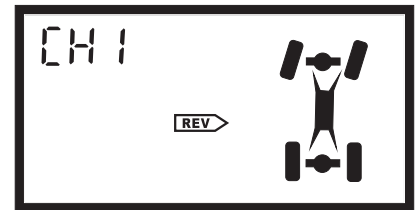
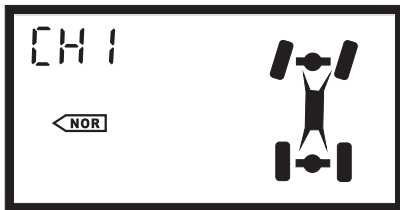

Throttle Trim/Throttle Reverse Switch



LCD screen on the transmitter

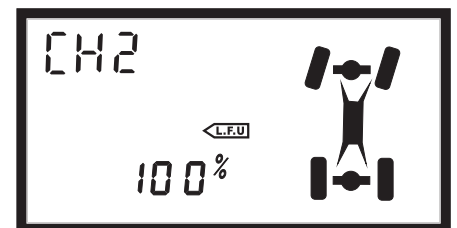
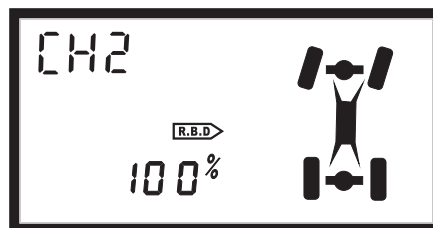

TRM. TH (Throttle Trim) range is around 0-100%. Toggle this switch to select the desired throttle trim amount.

To Reverse Throttle:

Press SEL (Select Button) on your radio until the LCD display appears as Channel 2 (NOR.)

Toggle the SWITCH (Steering Trim /Reverse Switch) to change from NOR to REV as shown below:

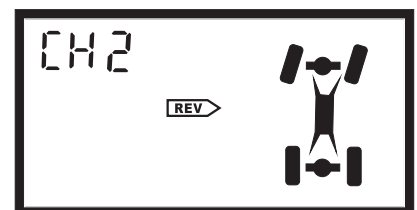
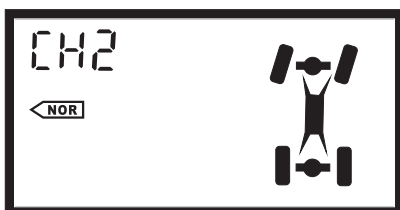

Steering Dual Rate (D/R)

This lever adjusts the overall travel of the steering servo, push the lever forward for maximum steering. Pull the lever back to reduce steering travel. D/R adjustable range is around 5-100%.

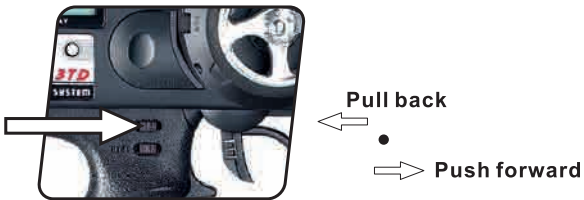

LCD screen on the transmitter

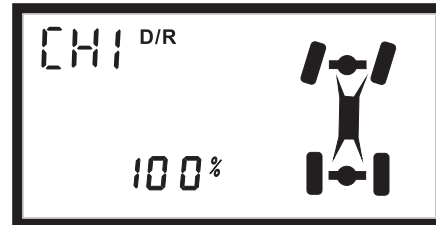

Trim Switch (For Rear Wheels)

This dial is to center the rear wheels. The range is 0-100% in either direction.



LCD screen on the transmitter

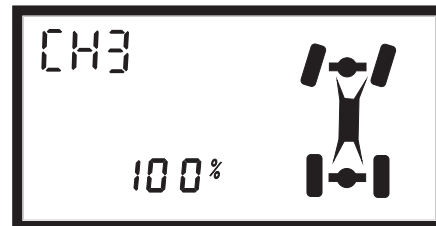

Steering Wheel



Controls steering. Turn the wheel to the right and the crawler turns right. Turn the wheel to the left and the crawler turns left.

Throttle/Brake Trigger



Controls forward motion, braking, and reverse. Pull the trigger to move forward, release the trigger to decelerate, and push the trigger to brake. Pushing the trigger a second time activates the reverse function.

SEL Function Button

This 2.4GHz transmitter contains various select functions. While pressing the SEL button, the transmitter will cycle through the different functions with each touch of the button.



5. ESC And Receiver Placement

The RS10XT is a fully assembled RTR vehicle. The following is intended to familiarize you with the placement of electrical components.

Electronic Speed Controller (ESC)

The ESC is attached to the radio tray with foam mounting tape.

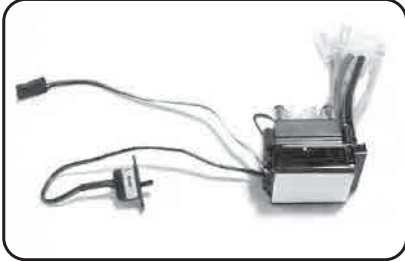

If you remove the ESC, clean off the old tape residue and use a new piece of foam mounting tape to re-install.

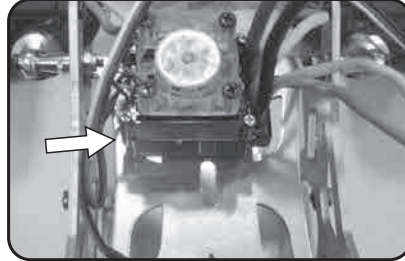

The power switch is secured with two self tapping screws. (2*6mm)- Screw No.: S093

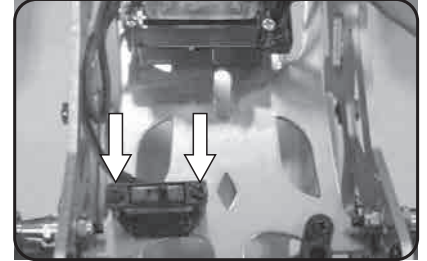

Receiver

The 2.4GHz receiver is attached to the radio tray with foam mounting tape.



If you remove the receiver, clean off the old tape residue and use a new piece of foam mounting tape to re-install.

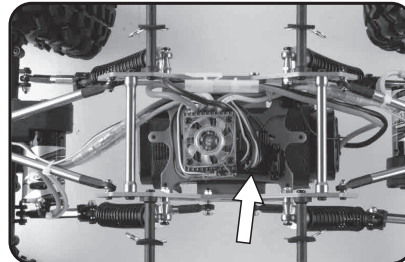

Slide the receiver antenna through the antenna mount (see the photo). Install the antenna tube (found in the package.) over the antenna and insert into the antenna mount.

The motor connectors (front/rear motor) are secured to the chassis with plastic ties. Be sure the yellow motor wire is connected to the yellow ESC wire and blue to blue.

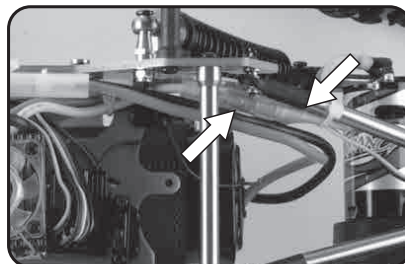
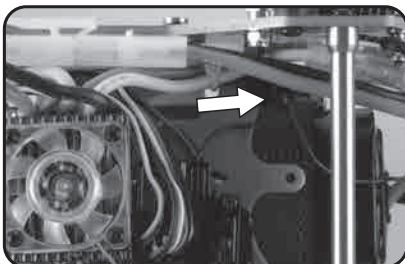

Splash-proof Receiver

The new splash-proof 2.4Ghz receiver is provided with an extra binding plug.

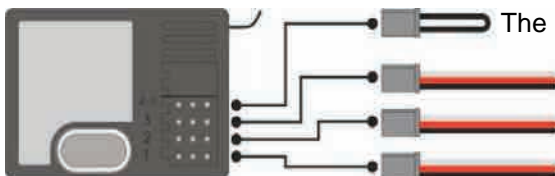

The binding plug (to Channel 4)

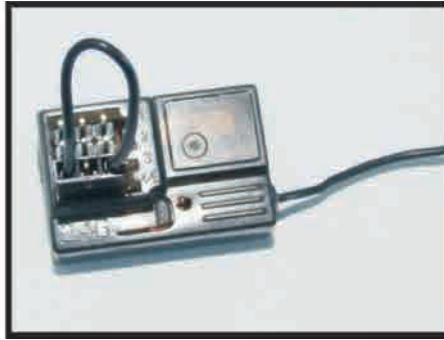
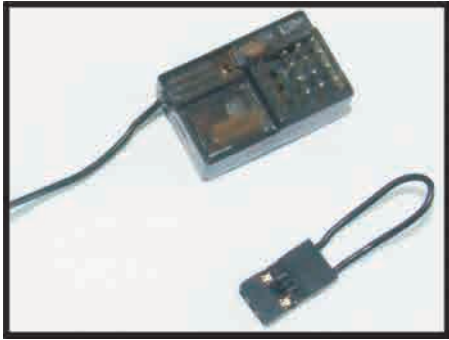

How to bind the receiver with the transmitter?

- 1) Insert the bind plug into Channel 4 before switching on the receiver.
- 2) Switch on the receiver. The LED light will flash.
- 4) Press and hold the SEL button on the transmitter.

The LED on the receiver will continue to flash. The radio is binding.

When the receiver's LED is lit solid, binding is complete.

Note: Repeat the above steps if binding fails.

- 5) Center the steering trim on the transmitter after binding is complete to set fail safe.
- 6) Remove the binding plug.

LED Indicator:

- RAPID FLASHING: BINDING IS IN OPERATION.
- SLOW FLASHING: NO SIGNAL WAITING FOR OPERATION
- SOLID LIGHT: IN OPERATION
- NO LIGHT: RECEIVER IS OFF, BATTERY IS DEAD OR MISSING, RECEIVER IS DISCONNECTED OR BROKEN

6. Turning the vehicle on/off



Transmitter Power Switch

To turn the vehicle on:

1. Switch on the transmitter.
2. Switch on the ESC power switch.

To turn off the vehicle:

1. Switch off the ESC power switch.
2. Switch off the transmitter.

Remember to remove the batteries from the vehicle and transmitter when not in use.

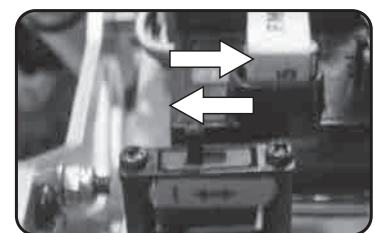

ESC power switch

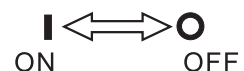

7. Charging the NiMH battery



WARNING

Never tempt to use this charger to charge the batteries of your transmitter.



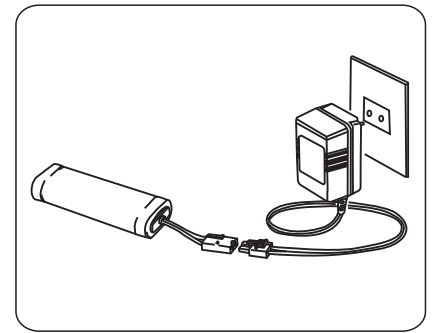













- Only use NiMH specific chargers to charge Ni-MH battery packs.
- Never overcharge your Ni-MH battery packs.
- Never charge the battery pack unattended.
- Always use the battery after it is fully charged.



8. Troubleshooting Guide

PROBLEM	CAUSE	REMEDY
Your RS10XT rock crawler fails to move.	<ol style="list-style-type: none"> 1) Transmitter or receiver is off. 2) Batteries are not placed correctly in the transmitter. 3) Battery pack on the car is low. 4) Transmitter and receiver are not bound correctly. 	<ol style="list-style-type: none"> 1) Turn both transmitter and receiver on. 2) Correctly align batteries in the transmitter. 3) Charge the battery pack. 4) Bind the transmitter and receiver.
Servo does not operate normally.	<ol style="list-style-type: none"> 1) Transmitter and/or receiver batteries are low. 2) Servo gears stripped or otherwise damaged. 	<ol style="list-style-type: none"> 1) Replace/recharge transmitter and/or receiver batteries. 2) Replace servo or servo gears.
Radio operates erratically.	<ol style="list-style-type: none"> 1) Transmitter batteries are low. 2) Radio is damaged from dropping. 	<ol style="list-style-type: none"> 1) Replace transmitter batteries. 2) Replace transmitter/receiver.
Operating range is short.	<ol style="list-style-type: none"> 1) Transmitter batteries are low. 	<ol style="list-style-type: none"> 1) Replace transmitter batteries.
Motor does not work.	<ol style="list-style-type: none"> 1) Motor wires loose or damaged. 	<ol style="list-style-type: none"> 1) Double-check motor wires. Repair/replace as necessary.
The crawler moves when turned on.	<ol style="list-style-type: none"> 1) Throttle Trim is out of adjustment. 	<ol style="list-style-type: none"> 1) Adjust Throttle Trim again.
Steering works, but throttle does not work.	<ol style="list-style-type: none"> 1) Motor wires are loose or damaged. 2) ESC is incorrectly plugged into the receiver. 	<ol style="list-style-type: none"> 1) Check motor wires. Plug in correctly and/or repair damage. 2) Plug the ESC into the receiver correctly.





PART LIST-1

RCT-H001	RCT-H111	RCT-H112	RCT-H004
 <p>Aluminum Side Plate (left/right)</p>	 <p>Upper Link Mounts + Screws 4pcs(Round Head Self Tapping Screw 2.6*8mm) + Screws 2pcs (Round Head Screw 2.5*17mm) + Washers 2pcs (2.5*5.5*0.5)</p>	 <p>Radio Tray+ Stick Battery Plate + Battery Strap+Screws 4pcs (Round Head Screw 2.5*6) + Nuts 4pcs (M2.5)</p>	 <p>Drive Shaft (front/rear) L=62.5mm</p> <p style="text-align: right;">2P</p>
RCT-H005	RCT-H007	RCT-H008	RCT-H009
 <p>Wheel Shaft (front/rear)</p> <p style="text-align: right;">2P</p>	 <p>Motor Pinion Gear(8T)+ Set Screw 2.5*2.5mm</p> <p style="text-align: right;">2P</p>	 <p>Wheel Frame(metal)+Cap Head Screw 2*8mm(12pcs)</p>	 <p>Aluminum Wheel Hex.+ Wheel Pin 2*10mm+Set Screw 3*3mm</p> <p style="text-align: right;">4P</p>
RCT-H010	RCT-H012	RCT-H013	RCT-H015
 <p>Aluminum Side Plate Post</p> <p style="text-align: right;">2P</p>	 <p>Gear Pin-1 (Dia.: 5mm, Length 41mm)</p> <p style="text-align: right;">2P</p>	 <p>Gear Pin-1 (Dia.:4mm, Length 21.6mm)</p> <p style="text-align: right;">4P</p>	 <p>Shock Set Bush</p> <p style="text-align: right;">8P</p>
RCT-H016	RCT-H017	RCT-H018	RCT-H019
 <p>Front/Rear Upper Linkage Ball Stud.(Dia.: 5.8mm)</p> <p style="text-align: right;">8P</p>	 <p>Front/Rear Lower Linkage Ball Stud.(Dia.: 5.8mm)</p> <p style="text-align: right;">8P</p>	 <p>Front/Rear Spur Gear Mount Pin 2*12mm</p> <p style="text-align: right;">6P</p>	 <p>Steering Hub Bush</p> <p style="text-align: right;">8P</p>











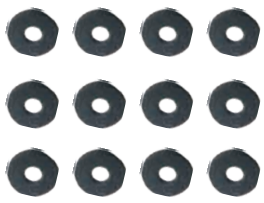

PART LIST-2

RCT-H020A	RCT-H021	RCT-H022	3338-H016
 <p>Linkage Bar Bolt</p>	 <p>Spring Pad(Inner Dia.:2.5mm) (apply to motor with screws)</p>	 <p>Washer(2.5*5.5*0.5mm) 8P Washer (3.1*6*0.5mm) 8P</p>	 <p>Gear Shaft Outdrive Cup {front/rear}</p> <p style="text-align: right;">2P</p>
H007	H009	H016	H032
 <p>Ball Bearing 5*11*4mm</p> <p style="text-align: right;">6P</p>	 <p>Ball Bearing 10*15*4mm</p> <p style="text-align: right;">4P</p>	 <p>Steering Linkage Ball Stud. (Dia.:5.8mm)</p> <p style="text-align: right;">8P</p>	 <p>Ball Bearing 4*7*2.5mm</p> <p style="text-align: right;">6P</p>
H036	H049	RCT-T001	RCT-T003
 <p>Ball Bearing 8*16*5mm</p> <p style="text-align: right;">6P</p>	 <p>Ball Bearing 4*9*4mm</p> <p style="text-align: right;">6P</p>	 <p>Front/rear Lower Linkage Set +4PCS of Ball Stud. (RCT-H017)</p>	 <p>Front/rear Steering Linkage Set+4pcs of Ball Stud. (H016)</p>
RCT-T004	RCT-T005	RCT-T006	RCT-T020
 <p>Front/rear Servo Linkage Set +4PCS of Ball Stud. (H016)</p>	 <p>Front/Rear Shock Set</p>	 <p>Front/Rear Spur Gear Complete</p>	 <p>Front/Rear Upper Linkage Set + 3pcs of Ball Stud.(RCT-H016) +1pcs of Ball Stud. (RCT-H017)</p>

















PART LIST-3

<p>RCT-P002</p>  <p>Servo Plate+Servo Mount+ Shock Lower Retainer 2P</p>	<p>RCT-P003</p>  <p>Front/rear Gear Box Housing + Dust Cover</p>	<p>RCT-P004</p>  <p>Front/rear Axle Assembly</p>	<p>RCT-P005</p>  <p>Spur Gear(47T)+Drive Gears+ Gear Gasket + Gear Seal Set + Gear Casing</p>
<p>RCT-P008</p>  <p>Body Post</p>	<p>RCT-P011</p>  <p>One Pair Wheel Complete (left/right) 2P</p>	<p>RCT-P060</p>  <p>Front/rear Steering Hub(left/ right)+ Linkage Set Kit</p>	<p>RCT-P070</p>  <p>Servo Arm+Power Switch Mount +Antenna Mount</p>
<p>H002</p>  <p>Lock Nut M3 6P</p>	<p>H003</p>  <p>Flange Lock Nut M4 6P</p>	<p>H017</p>  <p>Lock Nut M2.5 6P</p>	<p>H020</p>  <p>Body Clip A/B-Big 12P</p>
<p>H021</p>  <p>Body Clip A/B-Small 12P</p>	<p>H153</p>  <p>E-Clip (2MM) 8P</p>	<p>H205</p>  <p>Lower Linkage Washer (2.5*7*1.5mm) 8P</p>	<p>P011</p>  <p>Zip Tie (Small) 8P</p>

PART LIST-4

P019	P100	01003-CHARGER-T	E600T
 <p style="text-align: right;">2P</p> <p>Receiver Antenna Tube</p>	 <p style="text-align: right;">12P</p> <p>Body Post Pad</p>	 <p>U.S. Standard Ni-MH Battery Charger</p>	 <p>RC390 Motor (Front) Yellow Wire (-), Blue Wire(+)</p>
E600R	HX-2200MH-T	3CH-24GHZ-RADIO	E710
 <p>RC390 Motor (Rear) Blue Wire (-), Yellow Wire(+)</p>	 <p>Optional Reachable NiMH Battery Pack 7.2V, 2200mAh</p>	 <p>3 Channel 2.4GHz Radio with Receiver</p>	 <p>Receiver</p>
E401	HX-15CS	RCT-T007	RCT-H106
 <p>Crawler ESC</p>	 <p>15KGs Metal Gear Servo</p>	 <p>Optional Front/rear Diff. Assembly</p>	 <p>Optional Steer Gear Kit (motor pinion is 10T)</p>
S016	S018	S028	S029
 <p style="text-align: right;">12P</p> <p>Set Screw (M3*3mm)</p>	 <p style="text-align: right;">12P</p> <p>Round Head Self Tapping Screw (2.6*8mm)</p>	 <p style="text-align: right;">12P</p> <p>Round Head Screw (2.5*14mm)</p>	 <p style="text-align: right;">12P</p> <p>Round Head Self Tapping Screw (2.6*10mm)</p>

PART LIST-5

S030	S031	S059	S060
			
12P	12P	12P	12P
Round Head Self Tapping Screw (3*10mm)	Cap Head Screw (2*8mm)	Round Head Screw (3*8mm)	Round Head Screw (2.5*12mm)
S063	S089	S093	S098
			
12P	12P	12P	12P
Round Head Screw (2.5*17mm)	Round Head Self Tapping Screw (2.6*6mm)	Round Head Self Tapping Screw (2*6mm)	Round Head Screw (3*21mm)
S099	S100	S101	S102
			
12P	12P	12P	12P
Round Head Screw (3*14mm)	Round Head Screw (2.5*8mm)	Round Head Screw (2.5*6mm)	Countersunk Self Tapping Screw (2*6mm)
S104	S027	S015	S096
			
12P	12P	12P	12P
Round Head Screw (3*10mm)	Round Head Screw (2.5*10mm)	Step Set Screw (3*3-2*7mm)	Round Head Screw (3*24mm)

Assembly Diagram-1

Shock Assembly

RCT-T005

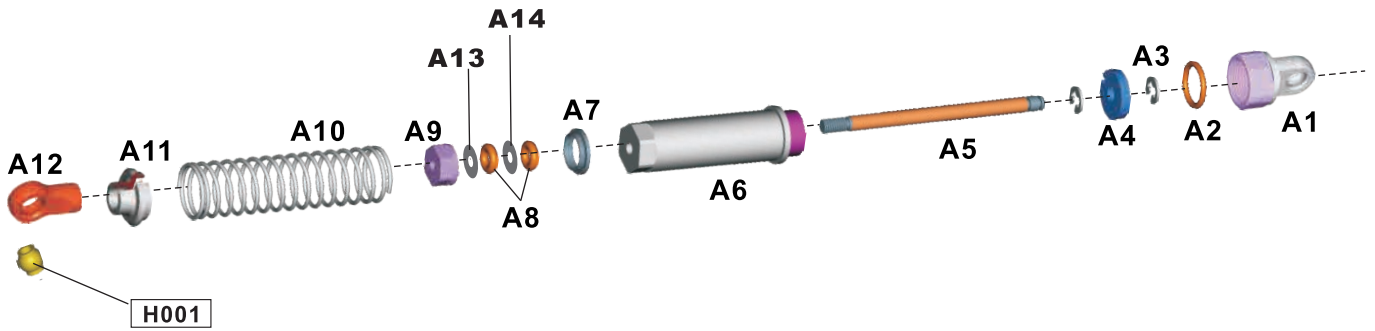

A13: washer (3*6*0.15mm)
 A14: washer (3*6*0.5mm)

Front/Rear Gear Box Assembly

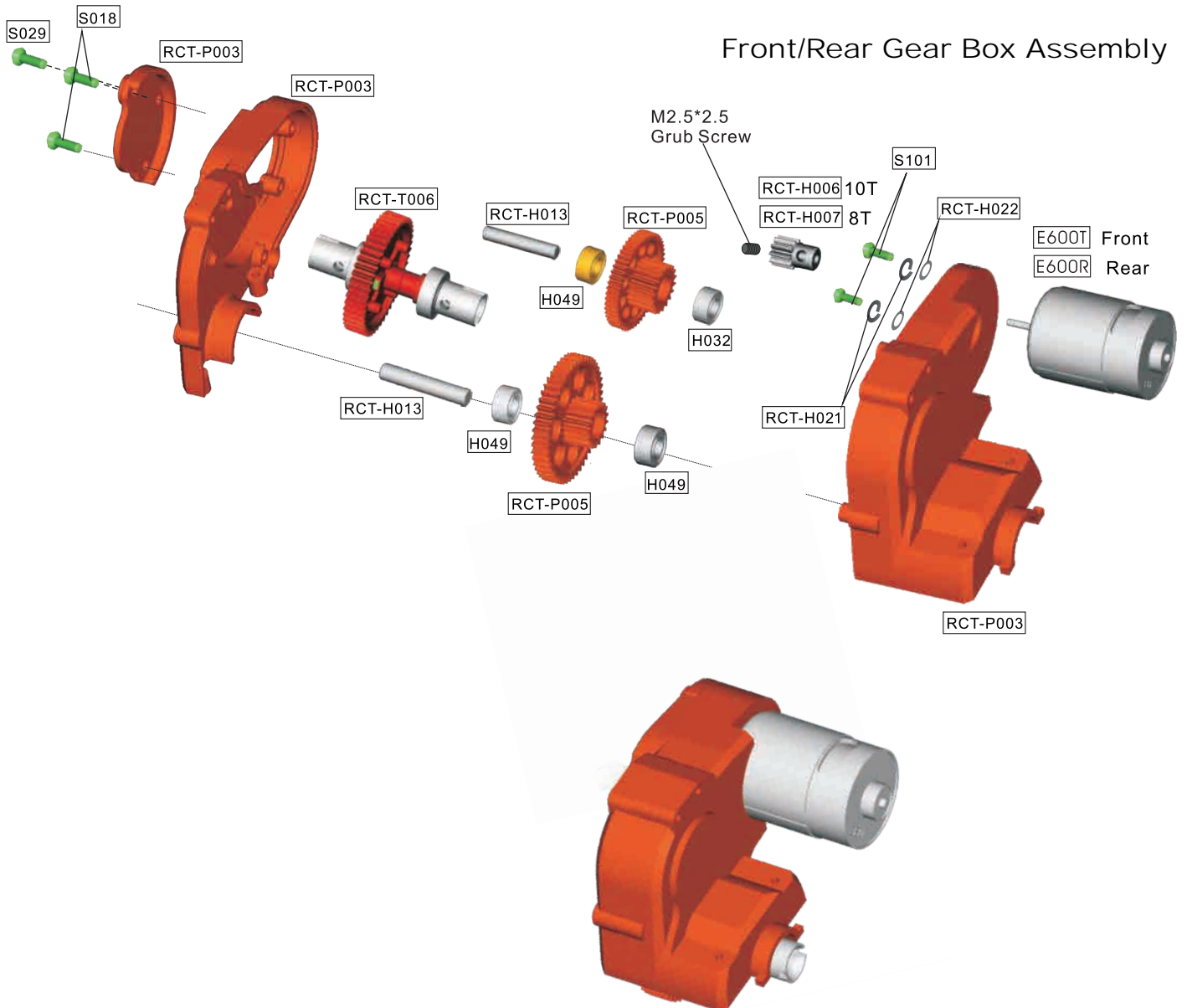

Assembly Diagram-2

Front/Rear Spur Gear Assembly

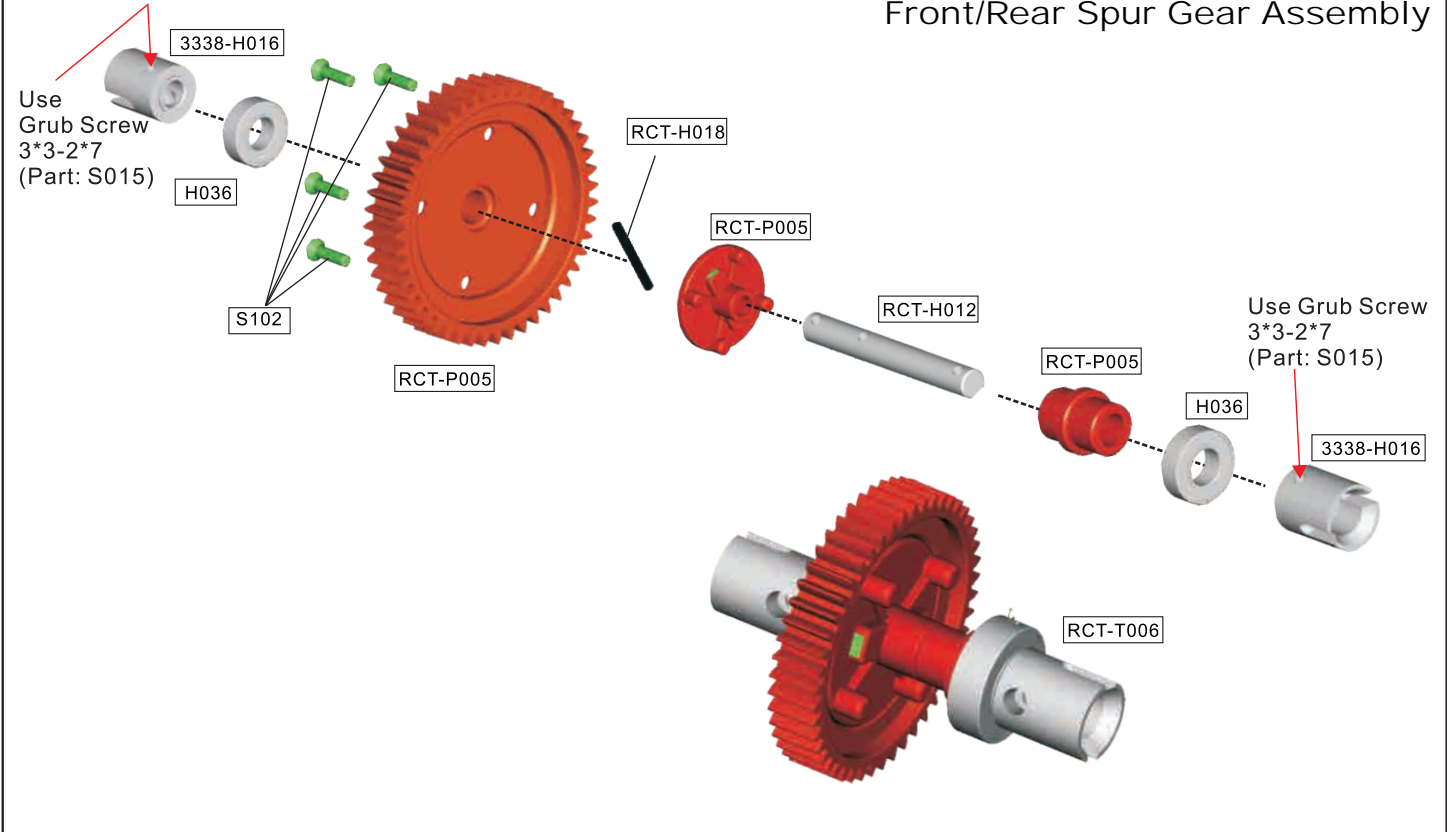

MODEL: RS10 XT



WWW.REDCATRACING.COM

MAN-RS10XT-2015.25.08-V4

- To ensure that you are using the most recent version of this manual:
www.redcatracing.com/manuals/RS10XTmanual.pdf
- To ensure that you have the most recent version of the Electronic Vehicles Manual:
www.redcatracing.com/manuals/ELECTRIC-MANUAL.pdf