

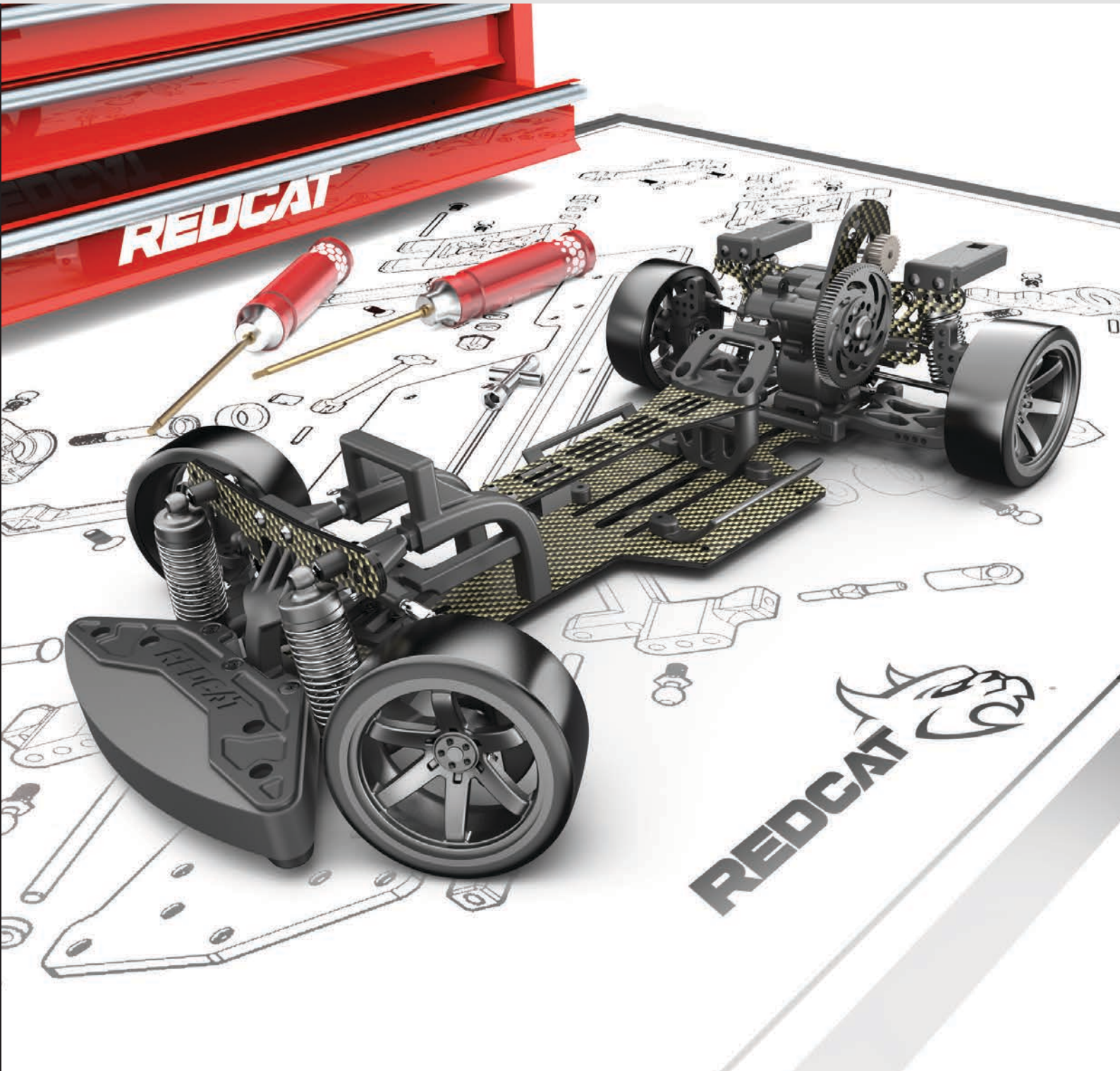

RDS

BUILDER'S KIT



1:10TH SCALE BRUSHLESS ELECTRIC
2WD COMPETITION SPEC DRIFT CAR

REDCATRACING.com

Warnings

AGE WARNING!

This radio controlled (RC) vehicle is not a toy. It is the responsibility of the parents or guardian to ensure that minors receive appropriate guidance and supervision when operating or working on this product.

It is the buyer's responsibility to ensure that this product is safely operated. You must be 14 years of age or older to operate this vehicle.

The buyer assumes all risks associated with the use of this product. Namero LLC d/b/a Redcat Racing and their retail partners, dealers, distributors, manufacturers and affiliates cannot control the use and operation of this product and as such shall not be held responsible or liable for any injury, accident or damage resulting from the use of this product.

Always fully read all instructions, manuals and warnings that come with your RC vehicle and any accessories required to operate the product.

Never operate your RC vehicles on public roads, near bystanders, children, pets or other animals.

Always leave a safe distance around your RC vehicles when driving so that in the event you lose control you don't damage the vehicle, hurt yourself or others.

Never lose sight of your vehicle while it is in operation and be aware of your surroundings.

Always keep clear of the wheels or other moving parts on the vehicle and never attempt to pick up the vehicle if the wheels are in motion.

Always perform a prerun inspection to ensure that there is no damage and that all screws and wheel nuts are secure. If damage is found, repair or replace prior to use.

Do not attempt to touch the motor, esc, battery or other electrical components during or immediately after use as these items will get hot during operation.

Always allow the vehicle time to cool down between runs. Overheating the electronics can shorten the life of your electronic components.

Never leave the battery connected when not in use and store batteries in accordance with manufacturer's instructions.

Never leave a battery unattended while being charged. Never charge batteries while they are inside of the RC vehicle.

There is a risk of fire and explosion when dealing with batteries. Rechargeable batteries may become hot and catch fire if left unattended or charged too quickly.

Always use extra caution when charging LiPo batteries.

Always, only use a LiPo specific chargers when charging LiPo batteries.

Always use a LiPo safe charging pouch when charging LiPo batteries.

Always charge batteries away from flammable materials and in a well ventilated space.

Never charge at a rate higher than 1C. (2000Mah pack = 2 amp charge rate). Overcharging can lead to fire and explosion.

Always store battery packs in a cool dry place.

Never use a LiPo battery that has previously overheated and/or shows signs of damage or swelling. If you suspect the battery to be damaged, immediately discontinue use and properly dispose of the battery.

Never dispose of a LiPo battery with regular trash. To safely dispose of LiPo batteries, refer to your local disposal authority or recycling center.

Always check the ESC settings to ensure that they match the battery type during operation. If using a LiPo battery, the ESC must be set to LiPo or damage may occur.

Never mix old and new batteries. Do not change or charge batteries in a hazardous location. Do not mix alkaline, lithium, standard (carbon zinc), or rechargeable (NiMH, cadmium) batteries.

If you do not agree with or are unable to follow these warnings and are not willing to accept full and complete liability for the use of this RC product; immediately return the product to your place of purchase in new and unused condition.

Advertencias

¡ADVERTENCIA SOBRE LA EDAD!

Este vehículo de radio control (RC) no es un juguete. Es responsabilidad de los padres o tutores garantizar que los menores reciban la orientación y supervisión adecuadas cuando manipulen este producto.

Es responsabilidad del comprador asegurarse de que este producto funcione de manera segura. Debe tener 14 años de edad o más para poder manipular este vehículo.

El comprador asume todos los riesgos asociados con el uso de este producto. Namero LLC d/b/a Redcat y sus socios minoristas, vendedores, distribuidores, fabricantes y afiliados no pueden controlar el uso y el funcionamiento de este producto y no serán responsables de ninguna lesión, accidente o daño que resulte por el mal uso de este producto.

Siempre lea absolutamente todas las instrucciones, manuales y advertencias que vienen con su vehículo RC y los accesorios necesarios para manipular el producto.

Nunca manipule sus vehículos RC en carreteras públicas, cerca de peatones, niños, mascotas y otros animales.

Deje siempre una distancia segura alrededor de sus vehículos RC al conducir, de manera de que, en caso de que pierda el control, no dañe el vehículo y nadie salga herido.

Nunca pierda de vista su vehículo mientras está en funcionamiento y esté atento a su entorno.

Manténgase alejado siempre de las ruedas u otras partes móviles del vehículo. Nunca intente levantarlo si las ruedas están en movimiento.

Realice siempre una inspección previa al funcionamiento para asegurarse de que no haya daños y que todos los tornillos y tuercas de las ruedas estén bien puestos. Si encuentra algún daño, repárelo o reemplácelo antes de usarlo.

No intente tocar el motor, la esc, la batería u otro componente eléctrico durante o después de usarlo, ya que estos se calientan mientras funcionan.

Deje siempre que el vehículo se enfríe entre cada viaje. El sobrecalentamiento puede acortar la vida útil de los componentes electrónicos.

No deje nunca la batería conectada cuando no esté en uso y guárdela como indican las instrucciones del fabricante.

No deje nunca una batería sin supervisión mientras esté cargando. Nunca cargue la batería mientras se encuentre dentro del vehículo RC.

Existe un riesgo de incendio y explosión con las baterías. Las baterías recargables pueden calentarse e incendiarse si se dejan sin supervisión o se cargan muy rápido.

Tenga mucho cuidado cada vez que cargue una batería LiPo.

Solo use cargadores específicos para cargar las baterías LiPo.

Use una bolsa de carga segura Lipo cada vez que cargue las baterías.

Cargue siempre las baterías lejos de materiales inflamables y en un espacio ventilado.

No cargue nunca la batería con más de 1C. (2000Mah pack = carga de 2 amperios). La sobrecarga puede provocar incendios y explosiones.

Guarde los paquetes de las baterías en un lugar fresco y seco.

No use nunca una batería LiPo sobrecalentada y/o muestre daños o hinchazón. Si sospecha que la batería está dañada, deje de usarla inmediatamente y deséchela de manera adecuada.

No deseche nunca una batería LiPo junto a la basura normal. Para desecharlo de manera adecuada, consulte a las autoridades locales encargados de la recolección de basura o al centro de reciclaje.

Verifique la configuración de la ESC para asegurarse de que coincidan con el tipo de batería durante el uso. Si utiliza una batería LiPo, la ESC debe configurarse en LiPo ya que, de no hacerlo, ocasionaría daños.

Nunca mezcle baterías viejas y nuevas. No cambie ni cargue las baterías en un lugar peligroso. No mezcle las baterías alcalinas, de litio, estándar (carbón zinc) o recargables (NiMH cadmio).

Si no está de acuerdo con estas advertencias o no puede seguirlas y no está dispuesto a aceptar la responsabilidad total por el uso de este producto RC, devuelva el producto a su lugar de compra nuevo y sin uso.

Warnhinweise

ALTERS WARNUNG! Dieses funkgesteuerte (RC) Fahrzeug ist kein Spielzeug. Es liegt in der Verantwortung der Eltern oder des Erziehungsberechtigten, sicherzustellen, dass Minderjährige bei der Bedienung oder Arbeit an diesem Produkt eine angemessene Anleitung und Überwachung erhalten.

Es liegt in der Verantwortung des Käufers, sicherzustellen, dass dieses Produkt sicher betrieben wird. Sie müssen 14 Jahre oder älter sein, um dieses Fahrzeug zu betreiben.

Der Käufer trägt alle mit der Verwendung dieses Produkts verbundenen Risiken. Namerco LLC d/b/a Redcat Racing und ihre Handelspartner, Händler, Distributoren, Hersteller und verbundenen Unternehmen können die Verwendung und den Betrieb dieses Produkts nicht kontrollieren und sind daher nicht verantwortlich oder haftbar für Verletzungen, Unfälle oder Schäden, die durch die Verwendung dieses Produkts entstehen.

Lesen Sie immer alle Anweisungen, Handbücher und Warnhinweise, die mit Ihrem RC-Fahrzeug und dem für den Betrieb des Produkts erforderlichen Zubehör geliefert werden, vollständig durch.

Betreiben Sie Ihre RC-Fahrzeuge niemals auf öffentlichen Straßen, in der Nähe von Personen, Kindern und Haustieren anderer Tiere.

Lassen Sie während der Fahrt immer einen Sicherheitsabstand um Ihre RC-Fahrzeuge herum, damit Sie im Falle eines Kontrollverlustes das Fahrzeug nicht beschädigen, sich selbst oder andere verletzen.

Verlieren Sie Ihr Fahrzeug während des Betriebs nie aus den Augen und achten Sie auf Ihre Umgebung.

Halten Sie sich immer von den Rädern oder anderen beweglichen Teilen des Fahrzeugs fern und versuchen Sie niemals, das Fahrzeug aufzunehmen, wenn die Räder in Bewegung sind.

Führen Sie immer eine Vorlaufinspektion durch, um sicherzustellen, dass keine Schäden auftreten und alle Schrauben und Radmutter fest sitzen. Wenn Schäden festgestellt werden, reparieren oder ersetzen Sie diese vor der Verwendung.

Versuchen Sie nicht, den Motor, die Batterie oder andere elektrische Komponenten während oder unmittelbar nach dem Gebrauch zu berühren, da diese Gegenstände während des Betriebs heiß werden.

Lassen Sie dem Fahrzeug immer Zeit, sich zwischen den Fahrten abzukühlen. Eine Überhitzung der Elektronik kann die Lebensdauer Ihrer elektronischen Komponenten verkürzen.

Lassen Sie den Akku niemals angeschlossen, wenn er nicht in Gebrauch ist, und lagern Sie ihn gemäß den Anweisungen des Herstellers.

Lassen Sie einen Akku während des Ladevorgangs niemals unbeaufsichtigt. Laden Sie die Akkus niemals auf, während sie sich im Inneren des RC-Fahrzeugs befinden.

Beim Umgang mit Batterien besteht Brand- und Explosionsgefahr. Wiederaufladbare Batterien können heiß werden und Feuer fangen, wenn sie unbeaufsichtigt bleiben oder zu schnell geladen werden.

Seien Sie beim Laden von LiPo-Akkus immer besonders vorsichtig.

Verwenden Sie beim Laden von LiPo-Akkus immer nur ein LiPo-spezifisches Ladegerät.

Verwenden Sie beim Laden von LiPo-Akkus immer eine sichere LiPo-Ladetasche.

Laden Sie die Batterien immer außerhalb von brennbaren Materialien und in einem gut belüfteten Raum auf.

Laden Sie niemals mit einer Rate von mehr als 1C. (2000Mah Pack = 2 Ampere Laderate). Überladung kann zu Feuer und Explosionen führen.

Lagern Sie Akkupacks immer an einem kühlen, trockenen Ort.

Verwenden Sie niemals einen LiPo-Akku, der sich zuvor überhitzt hat und/oder Anzeichen von Schäden oder Schwellungen aufweist. Wenn Sie vermuten, dass der Akku beschädigt ist, stellen Sie die Verwendung sofort ein und entsorgen Sie den Akku ordnungsgemäß.

Entsorgen Sie einen LiPo-Akku niemals über den normalen Müll. Wenden Sie sich zur sicheren Entsorgung von LiPo-Akkus an Ihre örtliche Entsorgungsbehörde oder Ihr Recyclingzentrum.

Überprüfen Sie immer die ESC-Einstellungen, um sicherzustellen, dass sie während des Betriebs mit dem Batterietyp übereinstimmen.

Bei Verwendung eines LiPo-Akkus muss das ESC auf LiPo eingestellt sein, da sonst Schäden auftreten können. Mischen Sie niemals alte und neue Batterien. Wechseln oder laden Sie die Batterien nicht in explosionsgefährdeten Bereichen. Mischen Sie keine Alkali-, Lithium-, Standard- (Kohle-Zink) oder wiederaufladbaren (NiMH, Cadmium) Batterien. Wenn Sie mit diesen Warnhinweisen nicht einverstanden sind oder diese nicht befolgen können und nicht bereit sind, die volle und vollständige Haftung für die Verwendung dieses RC-Produkts zu übernehmen, senden Sie das Produkt unverzüglich in neuem und unbenutztem Zustand an Ihren Händler zurück.

Avertissements

AVERTISSEMENT D'ÂGE!

Ce véhicule radiocommandé n'est pas un jouet. Il incombe aux parents ou au tuteur de veiller à ce que les mineurs reçoivent les instructions et la supervision appropriées lorsqu'ils opèrent ou travaillent avec ce produit.

Il incombe à l'acheteur de s'assurer que ce produit est utilisé en toute sécurité. Vous devez être âgé de 14 ans ou plus pour utiliser ce véhicule.

L'acheteur assume tous les risques liés à l'utilisation de ce produit. Namerco LLC d/b/a Redcat Racing et leurs partenaires détaillants, distributeurs, fabricants et sociétés affiliées ne peuvent contrôler l'utilisation et le fonctionnement de ce produit et ne peuvent donc être tenus responsables des blessures, accidents ou dommages résultant de l'utilisation du produit.

Lisez toujours attentivement toutes les instructions, les manuels et les avertissements qui accompagnent votre véhicule radiocommandé ainsi que tous les accessoires nécessaires au fonctionnement du produit.

Ne conduisez jamais vos véhicules télécommandés sur la voie publique, à proximité de passants, d'enfants, d'animaux domestiques ou d'autres animaux.

Lorsque vous conduisez, laissez toujours une distance de sécurité autour de vos véhicules radiocommandés afin de ne pas endommager le véhicule, vous-même ou des tiers, en cas de perte de contrôle.

Ne perdez jamais de vue votre véhicule lorsqu'il est en marche et soyez conscient de votre environnement.

Tenez-vous toujours à l'écart des roues ou des autres pièces mobiles du véhicule et n'essayez jamais de le saisir si les roues sont en mouvement.

Effectuez toujours une inspection préliminaire afin de vous assurer qu'il n'y a aucun dommage et que toutes les vis et tous les écrous de roue sont bien fixés. Si des dommages sont constatés, réparez-les ou remplacez-les avant utilisation.

N'essayez pas de toucher le moteur, le compresseur, la batterie ou d'autres composants électriques pendant ou immédiatement après l'utilisation, car ces éléments chauffent pendant le fonctionnement.

Donner toujours du temps au véhicule de refroidir entre les courses. Une surchauffe de l'électronique peut raccourcir la durée de vie des composants électroniques.

Ne laissez jamais la batterie connectée quand vous ne l'utilisez pas et rangez-la conformément aux instructions du fabricant.

Ne laissez jamais une batterie sans surveillance pendant la charge. Ne chargez jamais les batteries lorsqu'elles sont à l'intérieur du véhicule radiocommandé.

Il y a un risque d'incendie et d'explosion lors de l'utilisation de batteries. Les piles rechargeables peuvent chauffer et prendre feu si elles sont laissées sans surveillance ou trop rapidement chargées.

Faites toujours très attention lorsque vous chargez des batteries LiPo.

Utilisez toujours uniquement des chargeurs LiPo spécifiques lors du chargement de batteries LiPo.

Utilisez toujours un étui de chargement sûr pour LiPo lors du chargement de batteries LiPo.

Chargez toujours les batteries loin de matériaux inflammables et dans un espace bien ventilé.

Ne chargez jamais à un taux supérieur à 1C. (Pack 2000Mah = taux de charge de 2 ampères). Une surcharge peut provoquer un incendie et une explosion.

Rangez les batteries toujours dans un endroit frais et sec.

N'utilisez jamais une batterie LiPo qui a déjà surchauffé et / ou présente des signes de dommage ou de gonflement. Si vous pensez que la batterie est endommagée, arrêtez immédiatement de l'utiliser et débarrassez-vous-en de manière appropriée.

Ne jetez jamais une batterie LiPo avec les ordures ménagères. Pour vous débarrasser en toute sécurité des batteries LiPo, contactez votre autorité d'élimination locale ou votre centre de recyclage.

Vérifiez toujours les paramètres ESC, pour vous assurer qu'ils correspondent au type de batterie pendant le fonctionnement. Si vous utilisez une batterie LiPo, le contrôleur doit être réglé sur LiPo, sinon vous risquez de l'endommager.

Ne mélangez jamais des batteries neuves et usagées. Ne changez pas et ne chargez pas les batteries dans un endroit dangereux. Ne mélangez pas des batteries alcalines, au lithium, standard (carbone zinc) ou rechargeables (NiMH, cadmium).

Si vous n'êtes pas d'accord avec ou n'êtes pas en mesure de suivre ces avertissements et si vous n'êtes pas prêt à assumer l'entière responsabilité de l'utilisation de ce produit radiocommandé, renvoyez immédiatement le produit à votre lieu d'achat, dans un état neuf et inutilisé.

BEFORE YOU START

Thank you for buying the RDS Drift Kit. Below are some requirements, suggestions and tips to help you complete your build. Before you start, be sure to read this manual from front to back, understanding all instructions and adhering to warnings. For more information on driving and setup help, please download the online manual: <https://www.redcatracing.com/pages/manuals>

Tools Needed

Flush Cut Side Cutters
 Hobby Knife
 Body Reamer
 Hex Drivers (1.3mm, 1.5mm, 2.0mm)
 Socket Drivers (5.5mm, 7.0mm)
 Adjustable Pliers (with padded jaws)
 Adjustable Wrench
 Turnbuckle Wrench (3.5mm)

Other Supplies Needed

Paint - For Clear Polycarbonate Bodies
 Paper Towels or Rags

Minimum Electronics Requirement

The RDS Builder's Kit does not include electronics. Below are the suggested minimum electronics needed to complete your build. We've created three categories to make choosing electronics easier.

Beginner

- 540 Sensorless Brushless Motor (~3300KV)
- Corresponding Sensorless Brushless ESC (60A +)
- Servo with around (0.13-0.09sec/60*) Speed
- Drift Specific Gyro (50Hz Max Output)
- NiMH/LiPo Battery pack (7.2V)
- Corresponding Charger

Intermediate

- 540 Sensored Brushless Motor (10-13 Turn)
- Fan for Motor is Recommended at this level
- Corresponding Sensored ESC (60-80A +)
- Servo with around (0.13-0.09sec/60*) Speed and (50-333Hz) Input Signal
- Drift Specific Gyro (50-333Hz Output)
- Shorty LiPo Battery Pack (7.2/7.4V +)
- Corresponding Charger

Advanced

- 540 Sensored Drift Specific Brushless Motor (10-13 Turn)
- Fan for Motor is Highly Recommended at this level
- Corresponding Sensored ESC with Boost/Turbo Capability (100-120A +)
- Servo with around (0.13-0.09sec/60*) Speed and (333Hz) Input Signal
- Drift Specific Gyro (333Hz Output)
- Shorty LCG LiPo Battery Pack (7.2/7.4V +)
- Corresponding Charger

Important Symbols

When you see the following symbols on a specific step, apply the product that corresponds with that symbol. Pay close attention to the color of the drop "O" icon and where it is located on the drawing, as this will tell you what product to apply to which part.



GREASE: Used to lubricate moving parts. When you see the GREASE symbol on a page, look for the WHITE drop "O" icon in the drawing and apply grease to the part it appears next to.
 Example: When the O icon is next to a gear, apply grease to that gear.



THREAD LOCK: Used to keep screws tight and can only be used on metal parts. Do not use when a screw is screwed into a plastic part. When you see the THREAD LOCK symbol on a page, look for the BLACK drop "O" icon in the drawing and apply thread lock to the part it appears next to.
 Example: When the O icon is next to a screw, apply a drop of thread lock to the threads of that screw before screwing it into place.



SHOCK OIL: Used to add dampening to the shocks. Applied to the shock O-rings and inside the shock body. When you see the SHOCK OIL symbol on a page, look for the GRAY drop "O" icon in the drawing. Pay close attention to the weight (wt) of the oil. The front shocks may take a different weight oil than the rear shocks. The higher the weight, the thicker the oil.



LEFT / RIGHT: Indicates a step is performed on the left and right sides of the part being worked on in that step.



FRONT / REAR: Indicates a step is performed on the front and rear of the part being worked on in that step.



TWO TIMES: Indicates an action is performed twice in that step.



FOUR TIMES: Indicates an action is performed four times in that step.

BAG A PLASTIC BAG 1

1 Rear

1 → 2 → 3

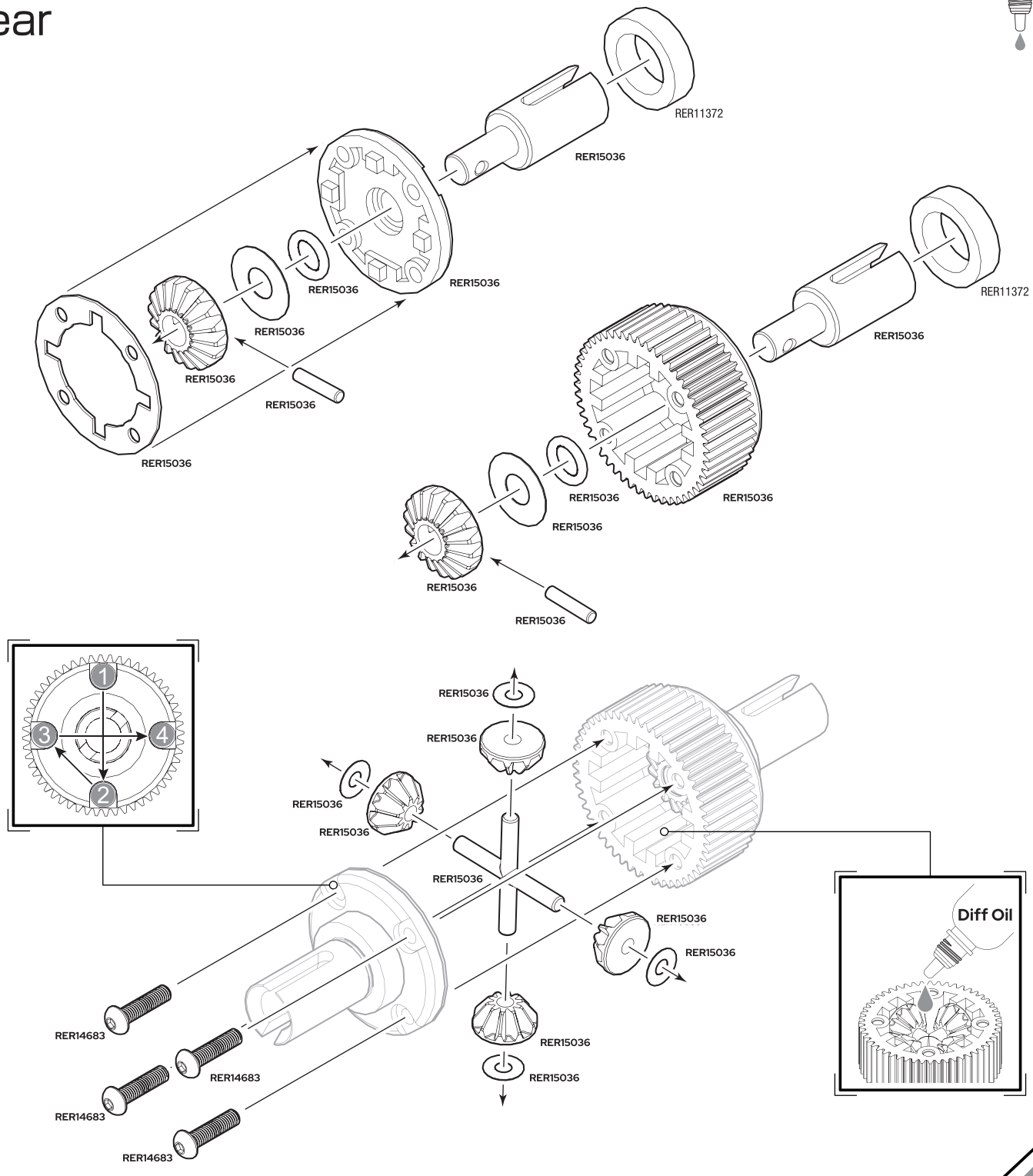

RER14683 x 4
M2.5x10mm

RER15036 x 2
2.0x8.8mm

RER15036 x 4
2.55 x 6.1 x 0.15mm

RER15036 x 2
5.0 x 11 x 0.2mm

RER11372 x 2
10x15x4mm

2

Rear

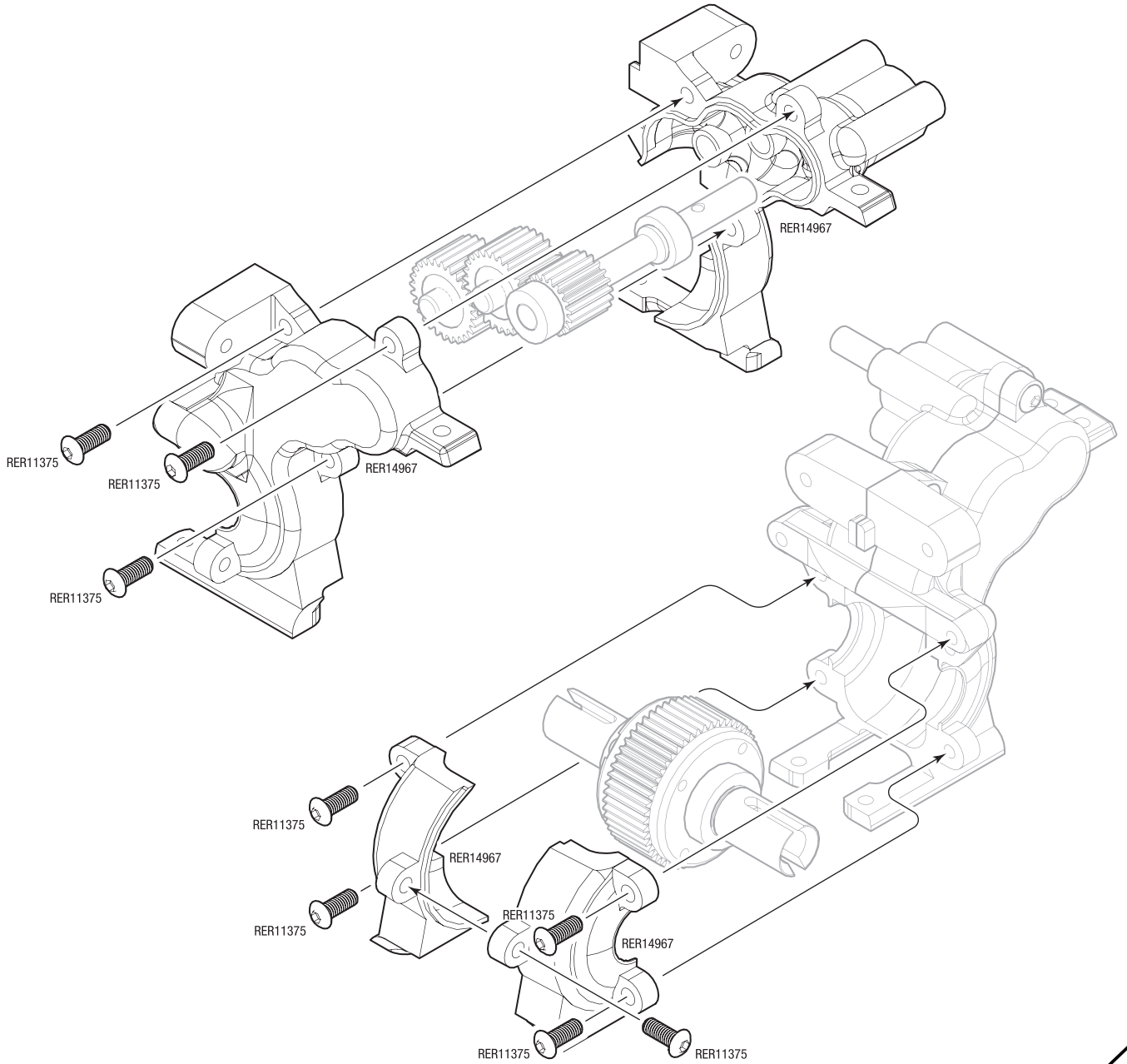
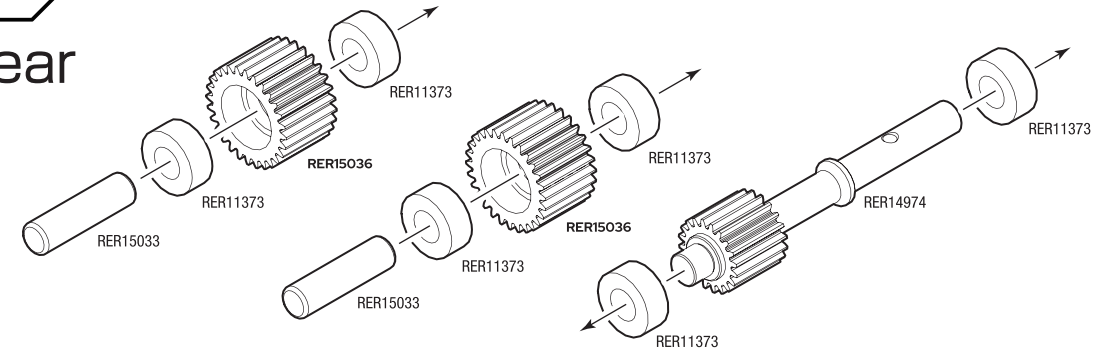

 RER11375 x 8
M3x8mm

 RER11373 x 6
5x10x4mm

3

Rear

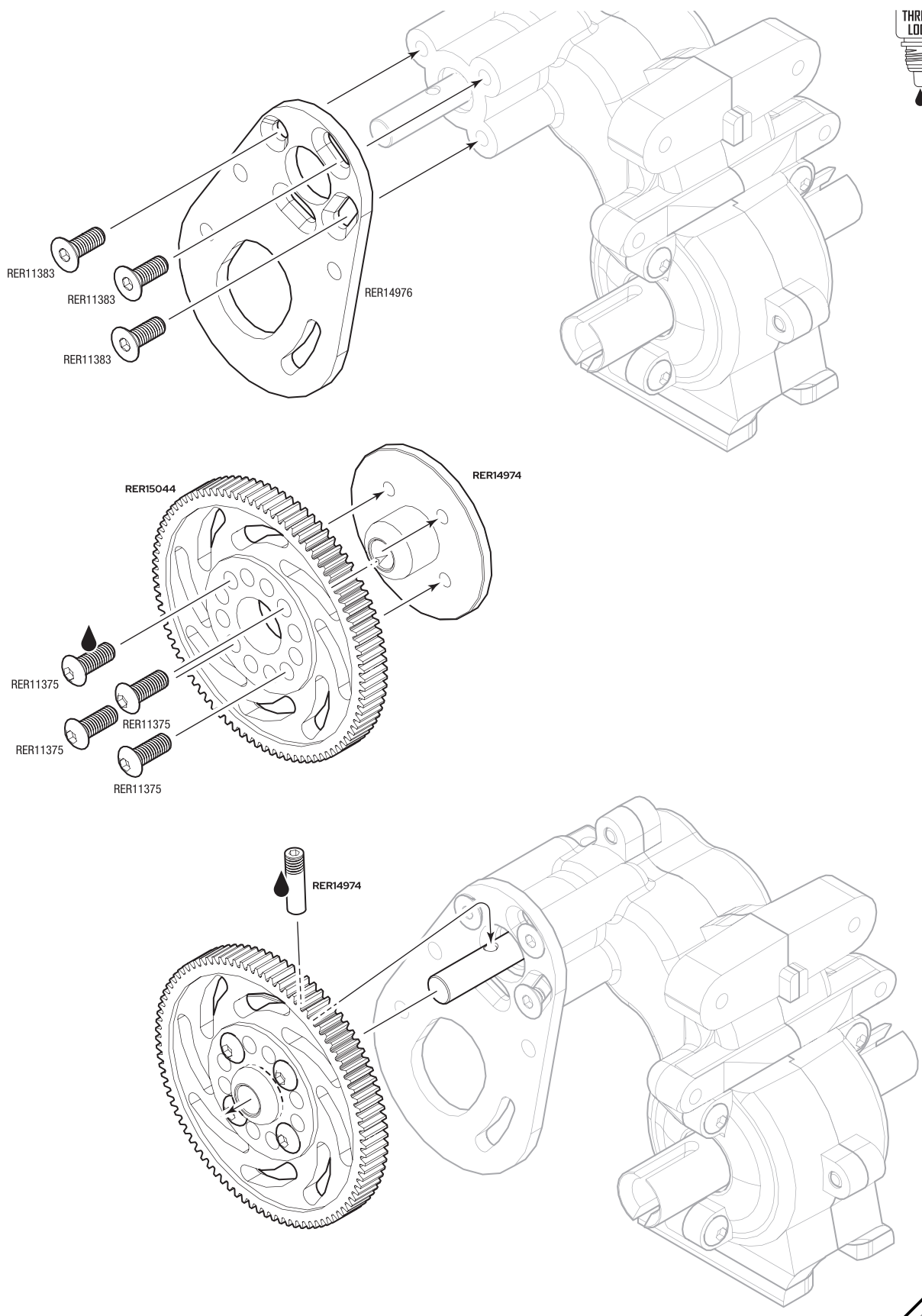

 RER11375 x 4
M3x8mm

 RER11383 x 3
M3x8mm

 RER14974 x 1
M3x2.5x11mm

4

Rear

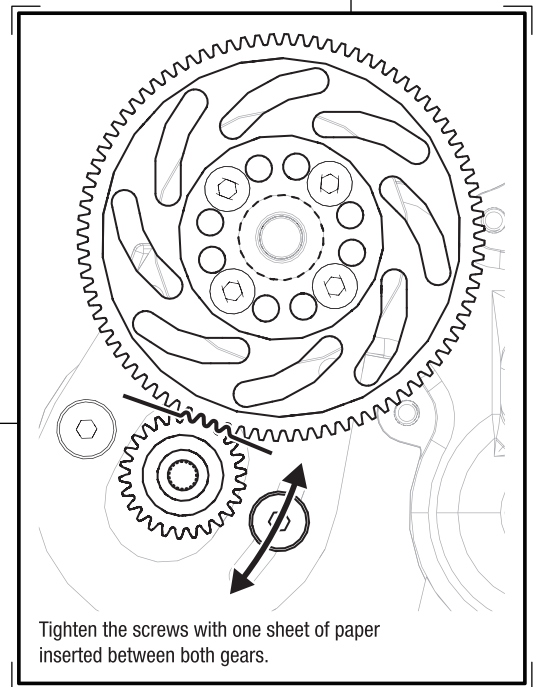
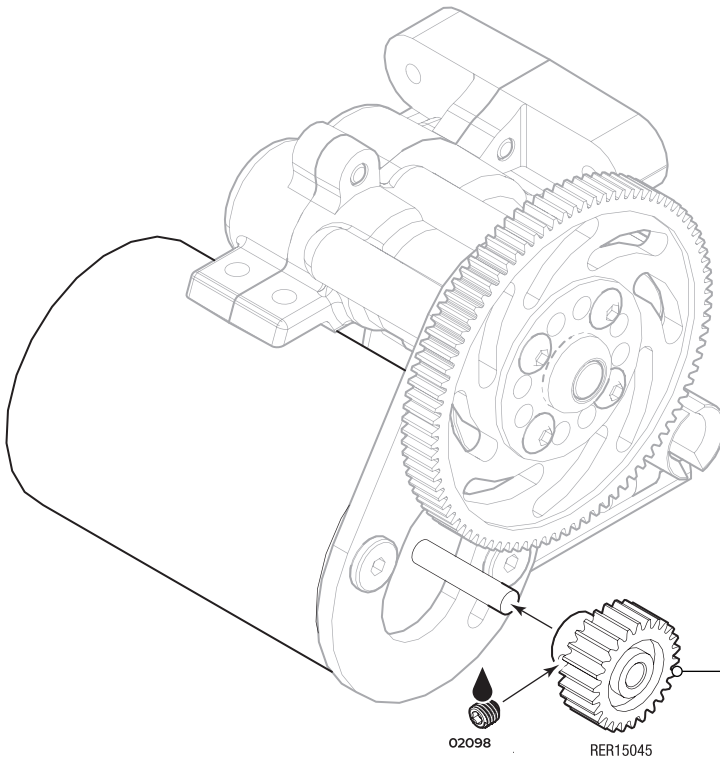
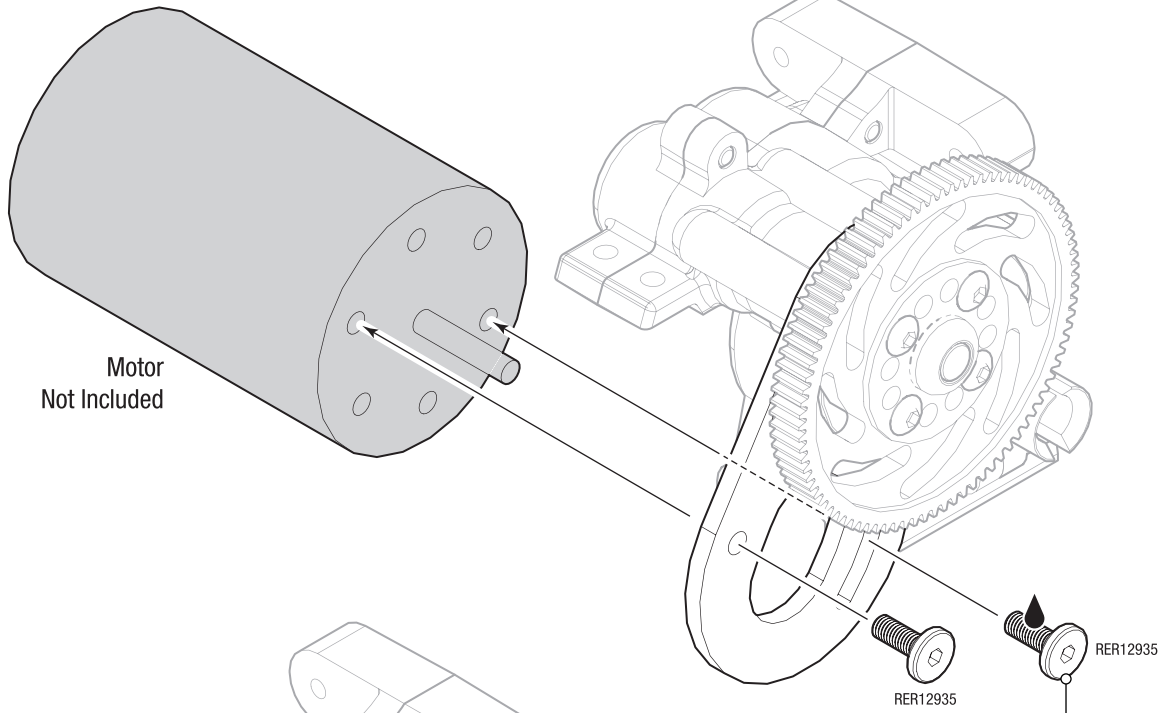

RER12935 x 2
M3x8mm



O2098 x 1
M3x3mm

BAG B

PLASTIC BAG 1

5 Front

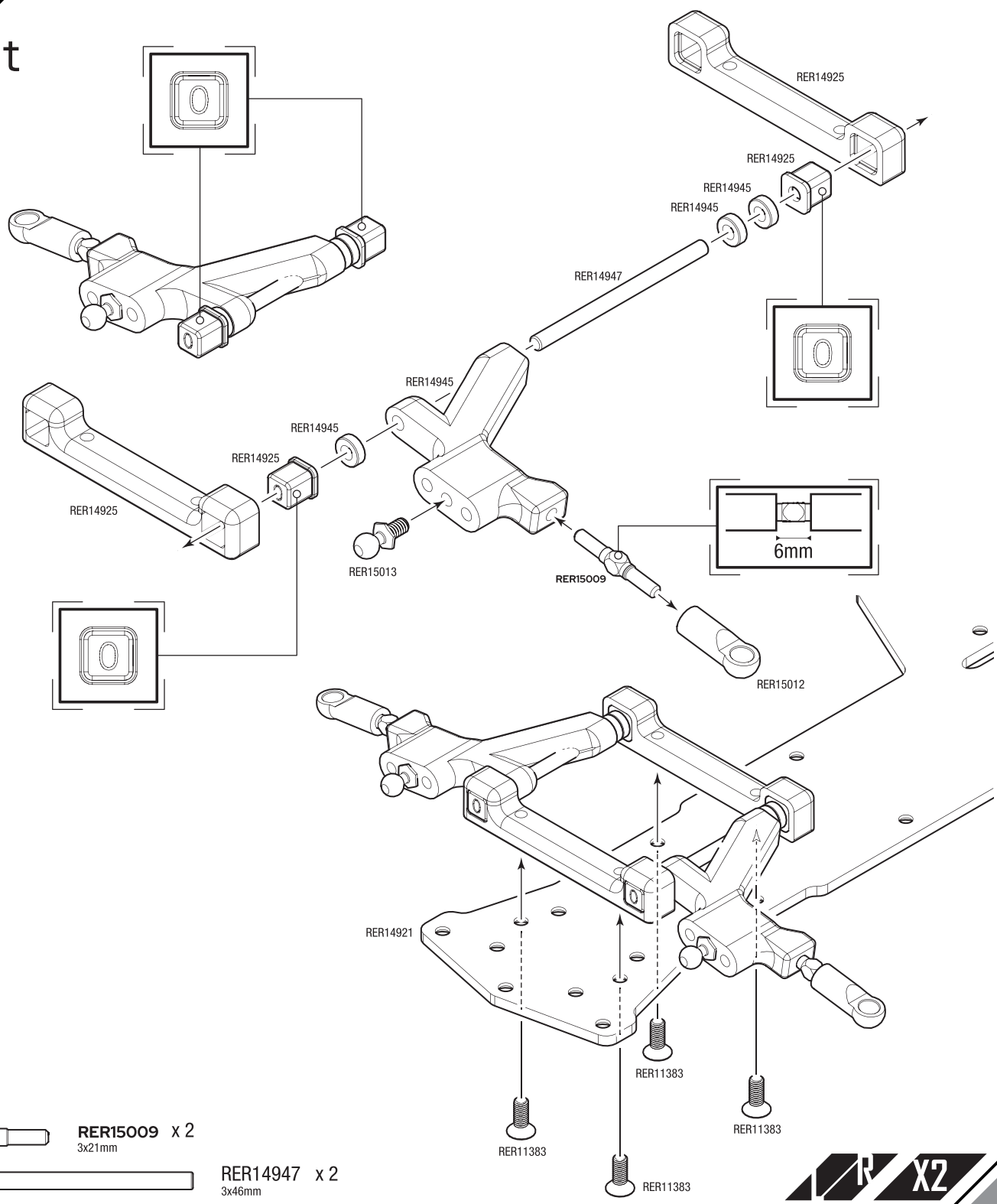

RER15009 x 2
3x21mm

RER14947 x 2
3x46mm

R X2

RER11383 x 4
M3x8mm

RER15013 x 2
4.8x6mm

6

Front

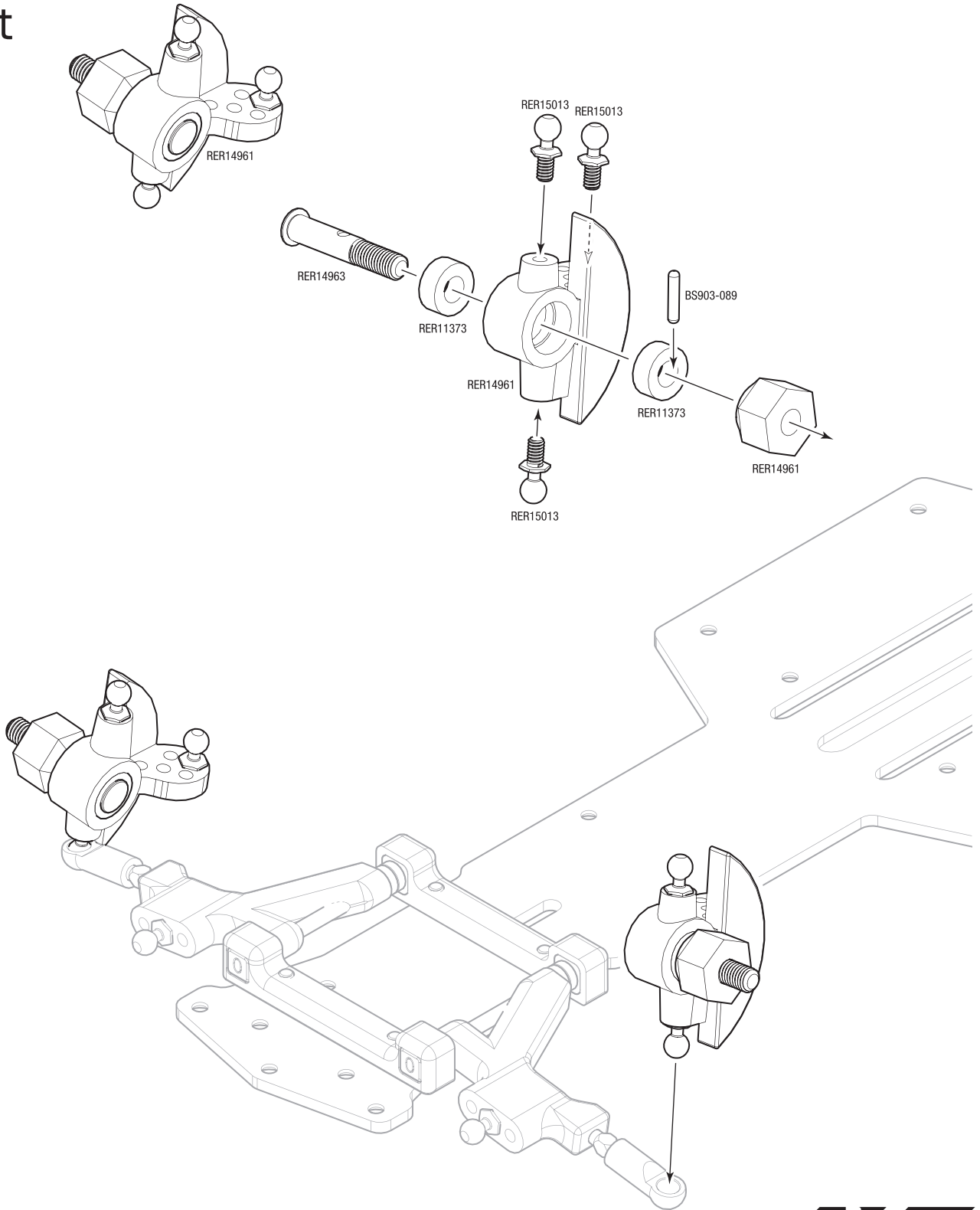

L R X2

 RER15013 x 6
4.8x6mm

 BS903-089 x 2
2x10mm

 RER11373 x 4
5x10x4mm

BAG C

PLASTIC BAG 1

7 Rear

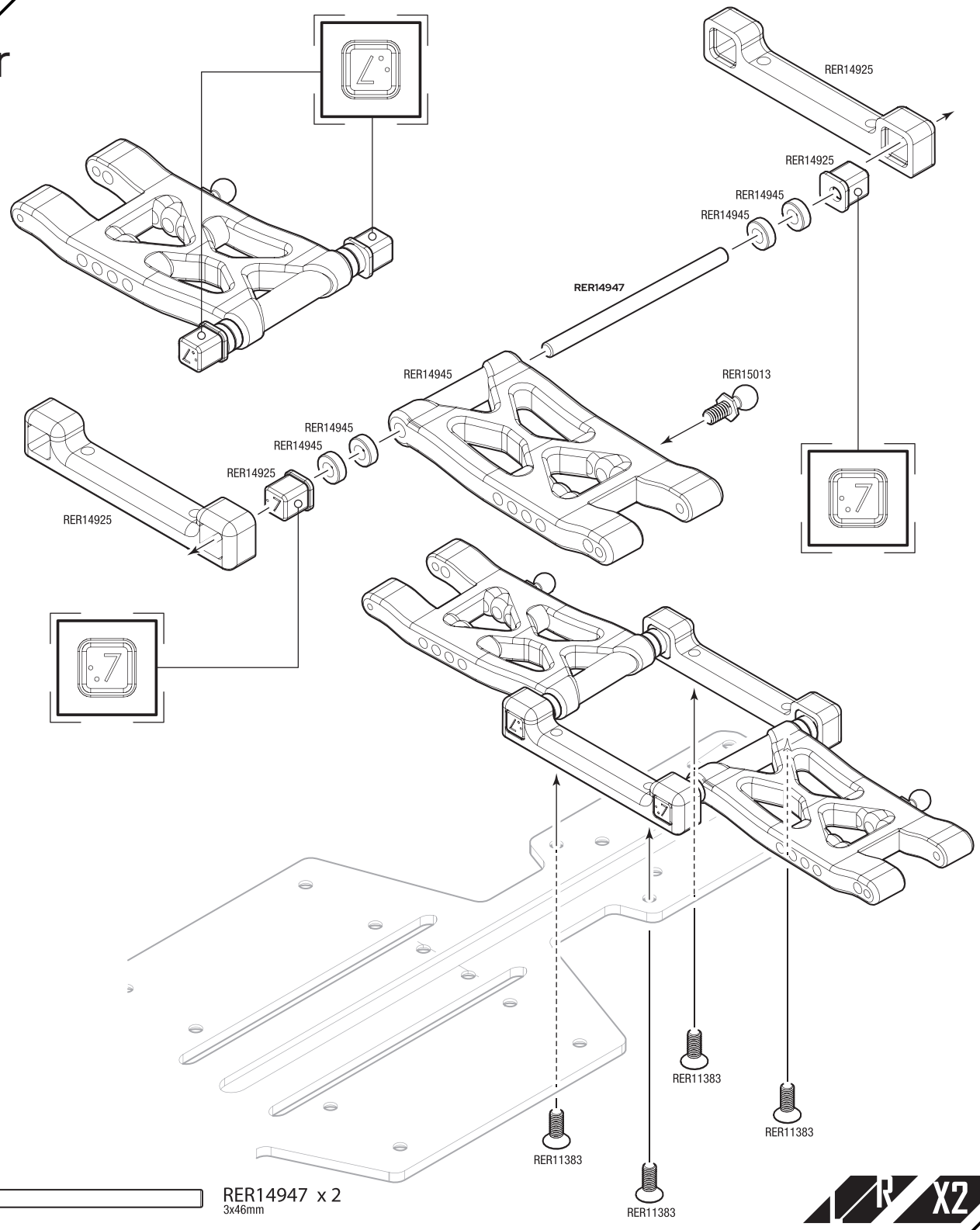

RER11383 x 4
M3x8mm

RER15013 x 2
4.8x6mm

8

1 → 2 → 3

Rear

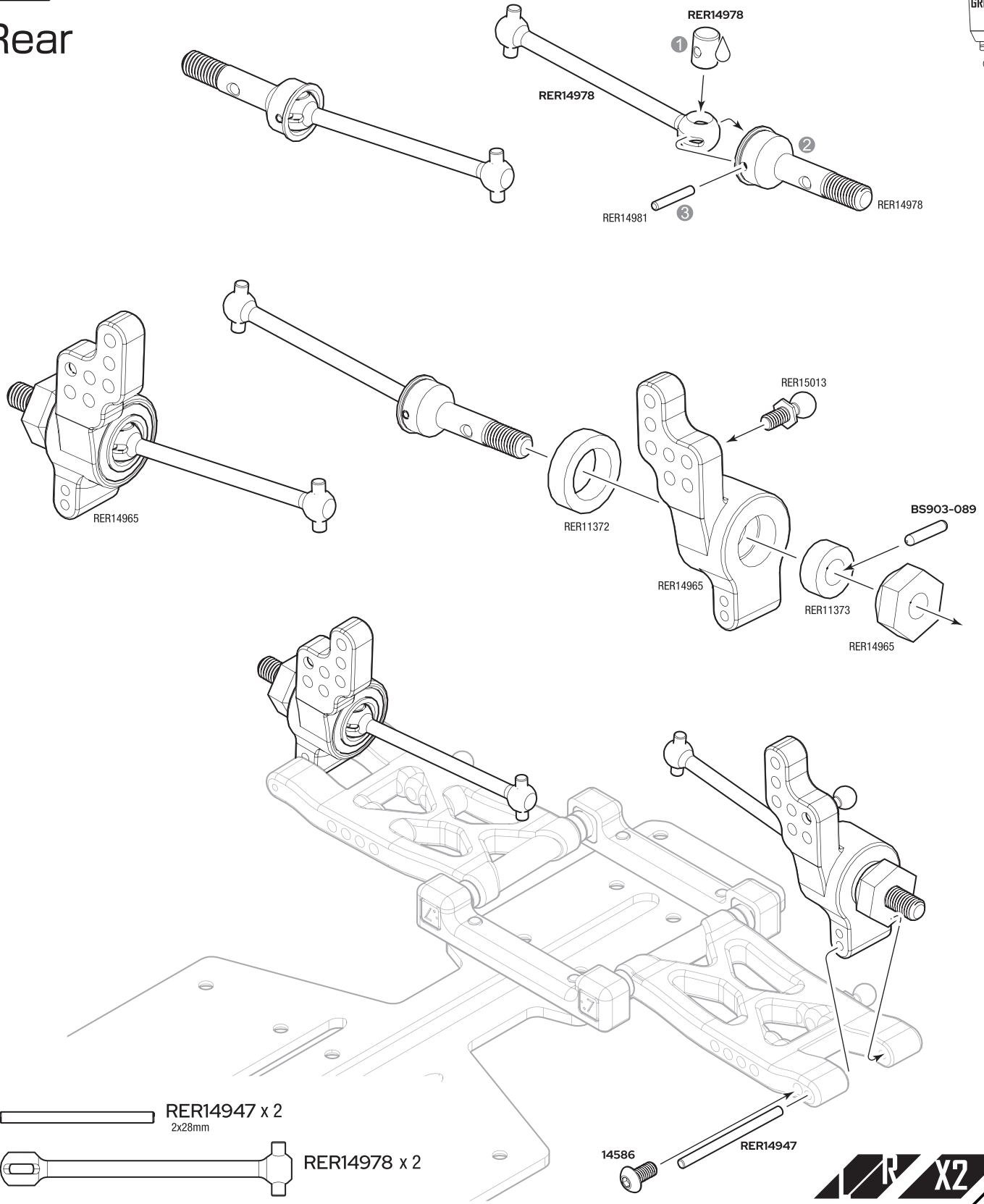

- RER14947 x 2
2x28mm
- RER14978 x 2

- 14586
M3x6mm
- RER15013 x 2
4.8x6mm
- RER14981 x 2
1.6x10mm
- BS903-089 x 2
2x10mm
- RER14947



- RER14978 x 2
- RER11373 x 2
5x10x4mm
- RER11372 x 2
10x15x4mm

BAG D

PLASTIC BAG 2

9 Front

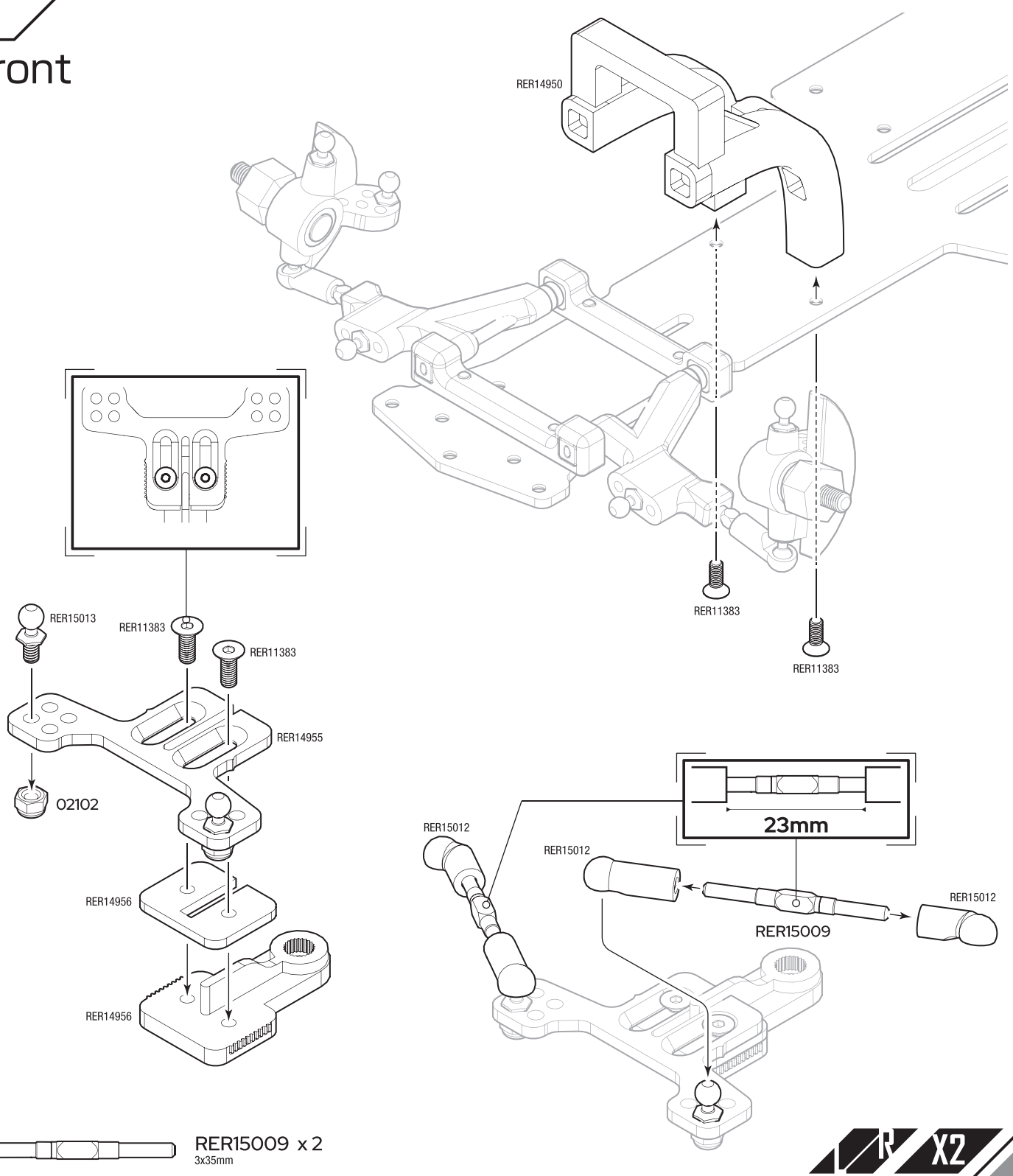

RER15009 x 2
3x35mm

RER11383 x 4
M3x8mm

RER15013 x 2
4.8x6mm

O2102 x 2
M3 Nut

10

Front

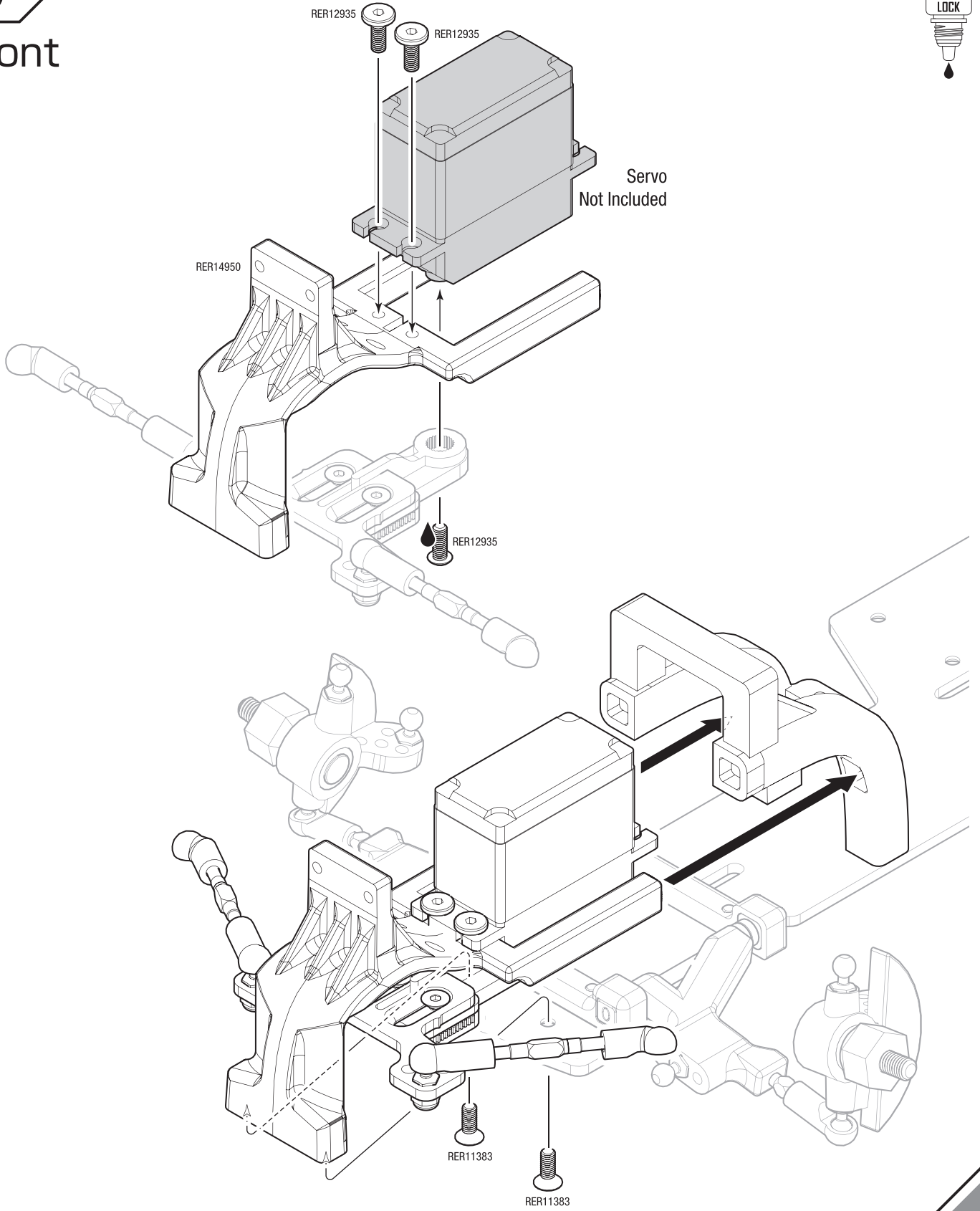

 RER11375 x 1
M3x8mm



 RER11383 x 2
M3x8mm

 RER12935 x 2
M3x8mm

11

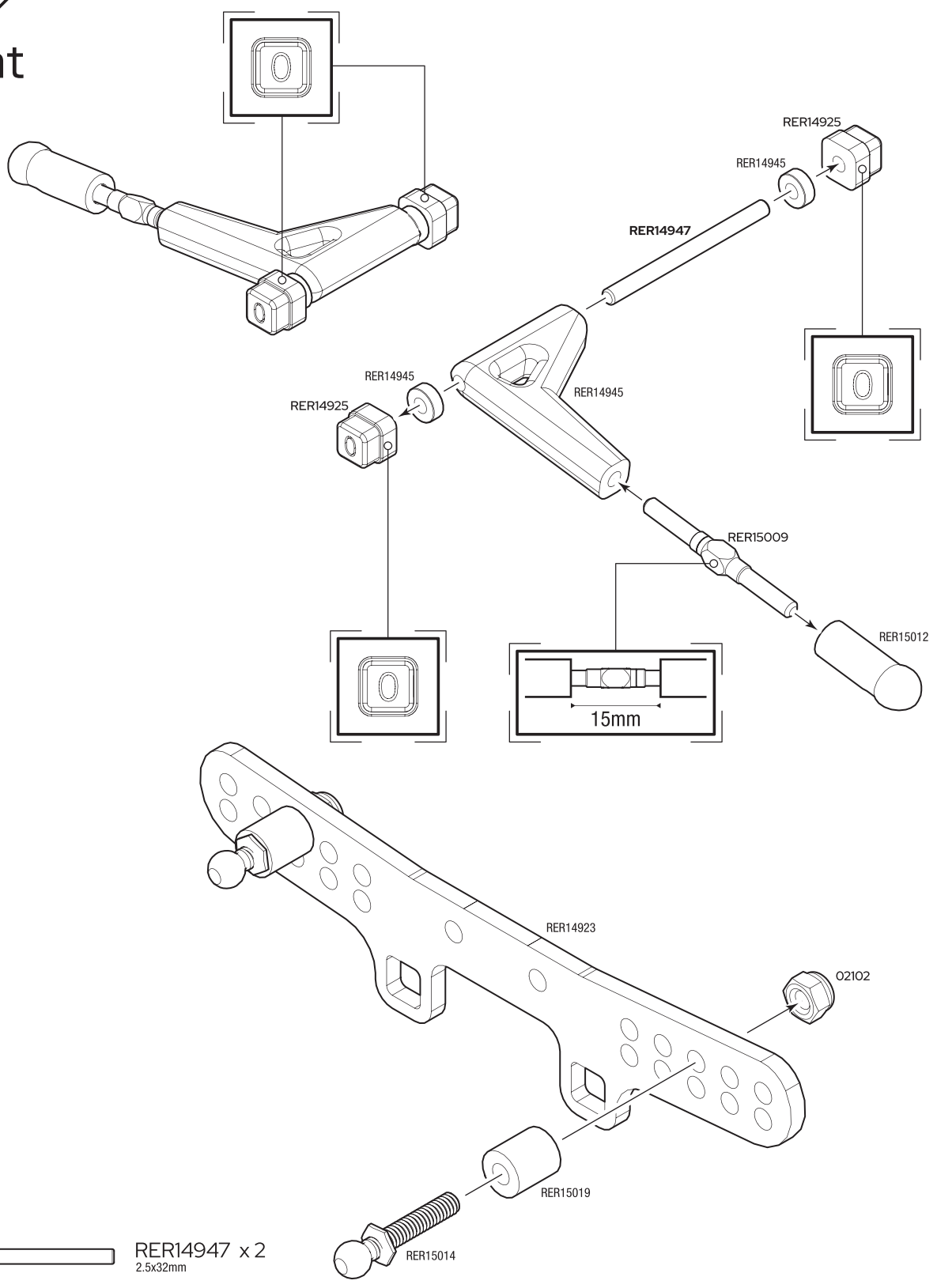
Front

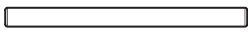

-  RER14947 x 2
2.5x32mm
-  RER15052 x 2
3x30mm



-  RER15014 x 2
4.8x13mm

-  O2102 x 2
M3 Nut

BAG E

PLASTIC BAG 2

13

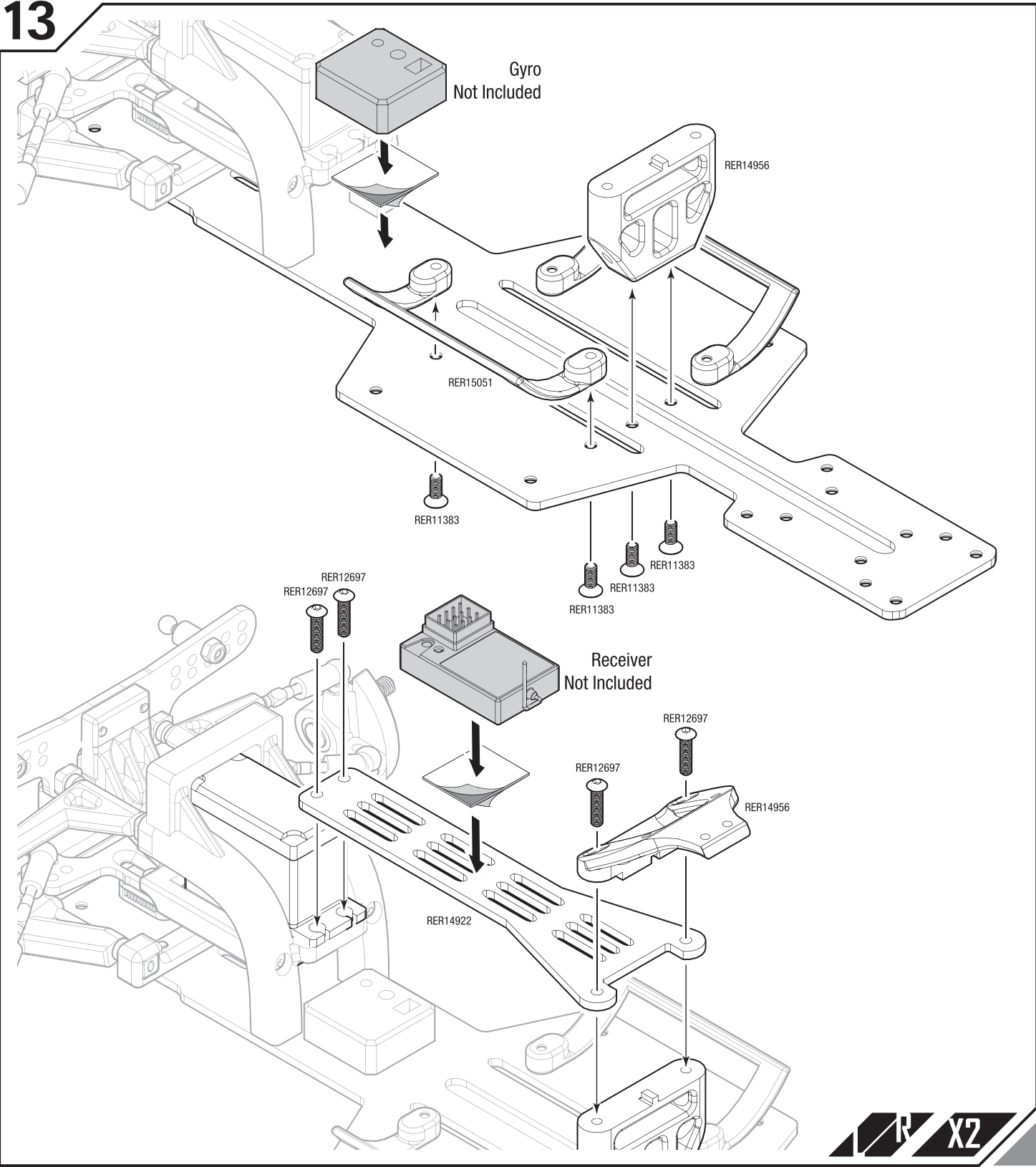

R X2

RER12697 x 4
M3x12mm

RER11383 x 4
M3x8mm

BAG F

PLASTIC BAG 2

14

Rear

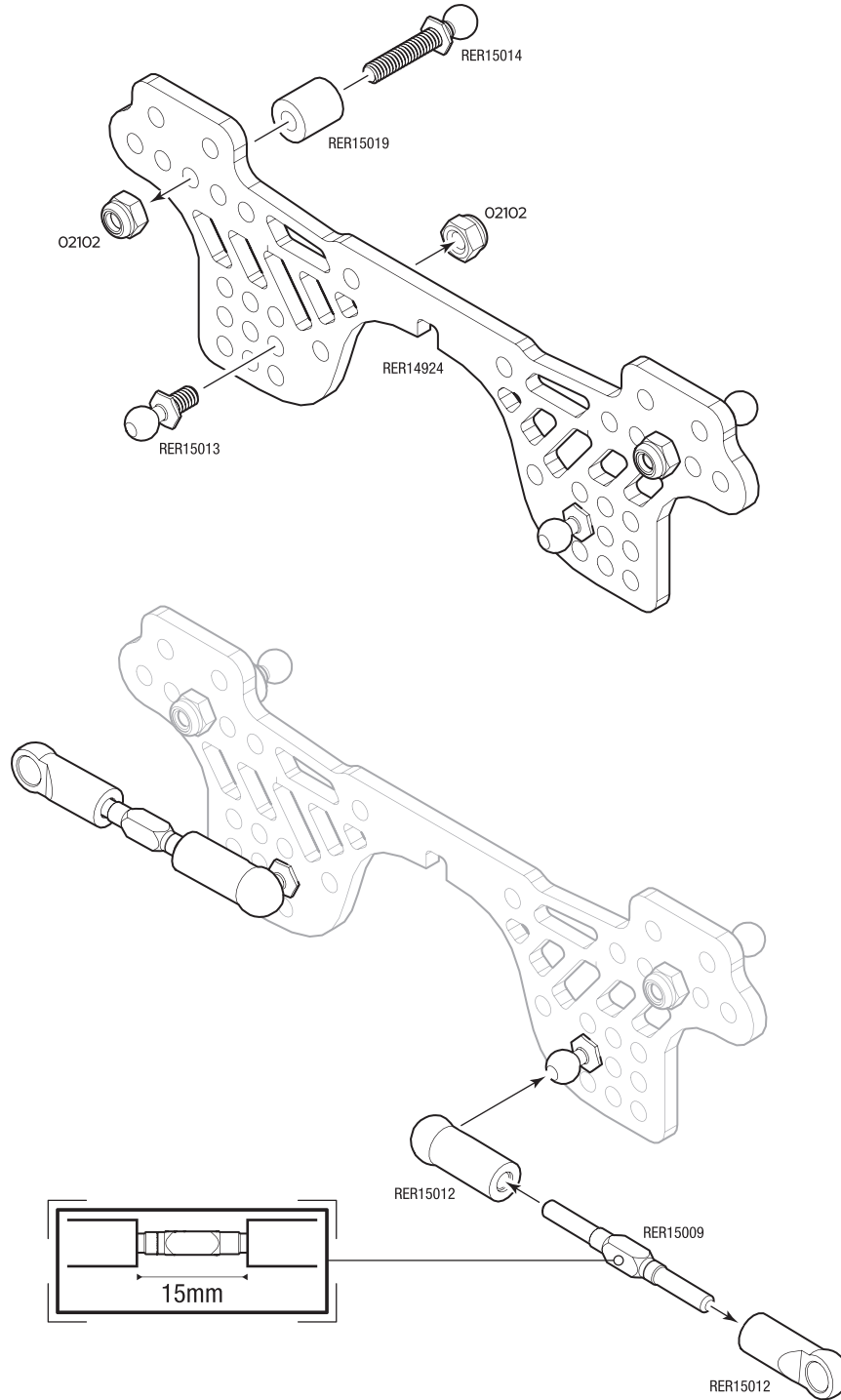

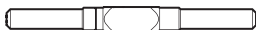
 RER15009 x 2
3x33mm

R X2

 RER15013 x 2
4.8x6mm

 RER15014 x 2
4.8x13mm

 O2102 x 4
M3 Nut

15

Rear

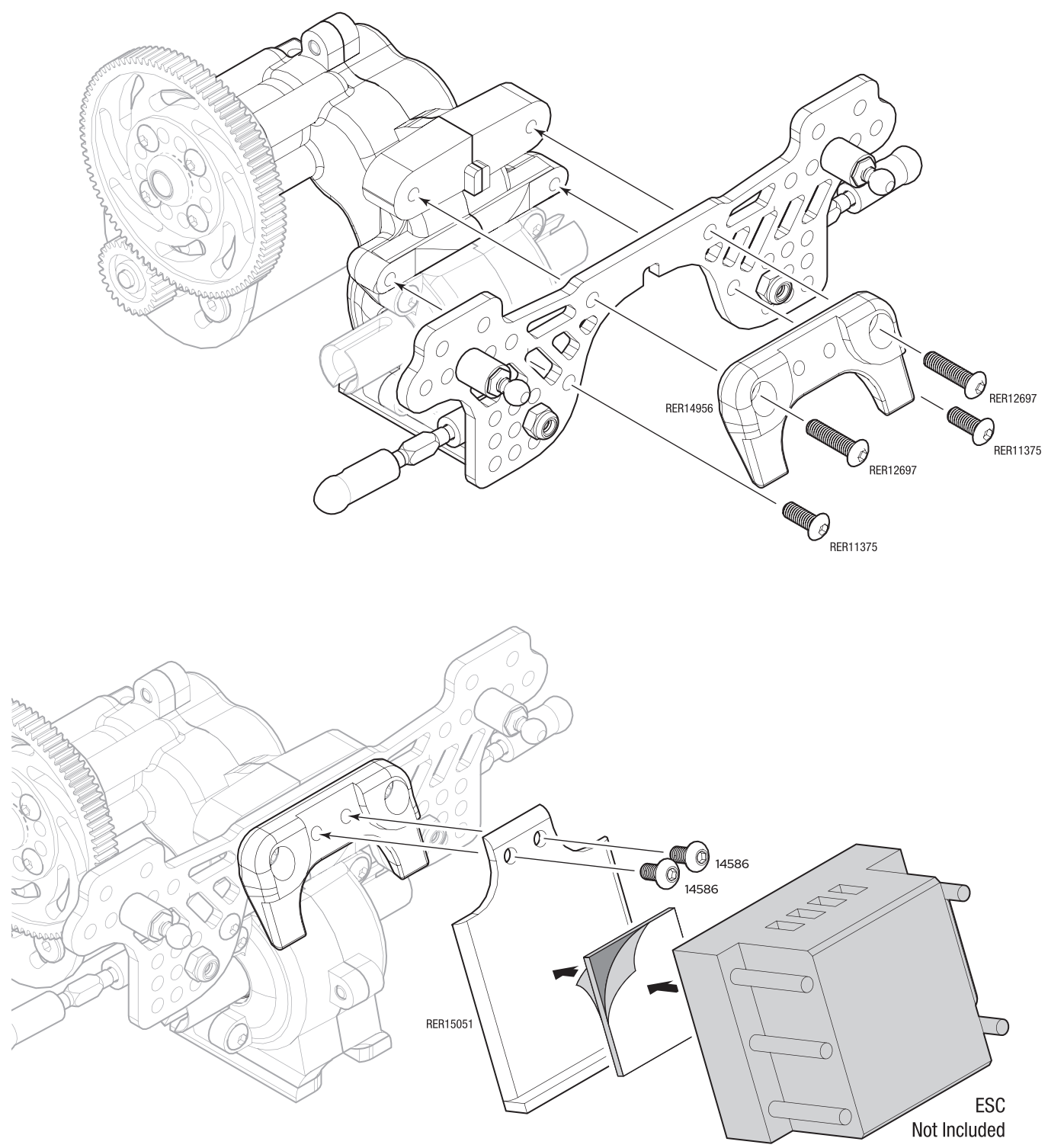

14586 x 2
M3x6mm

RER11375 x 2
M3x8mm

RER12697 x 2
M3x12mm

16

Rear

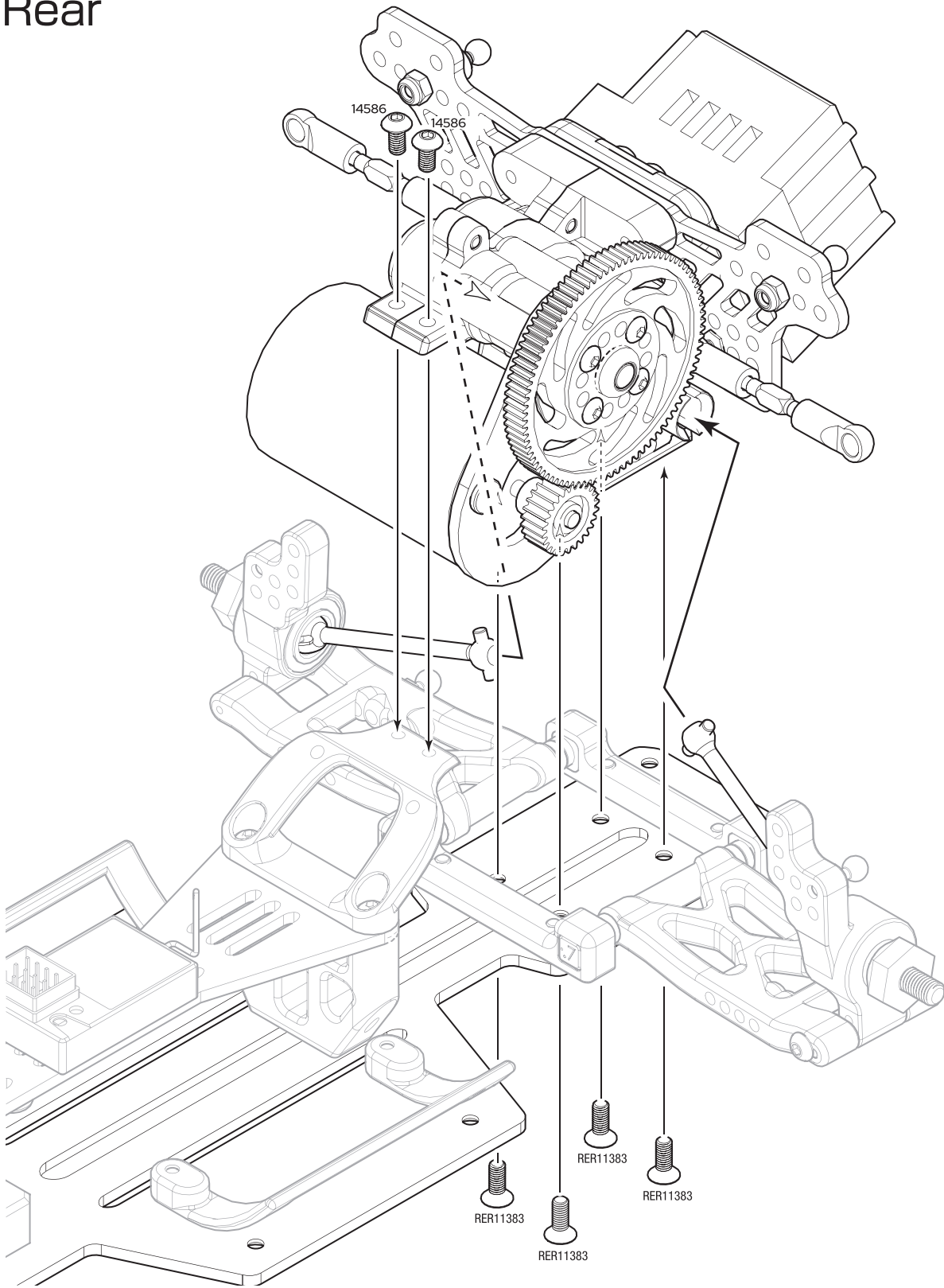

 14586 x 2
M3x6mm

 RER11383 x 4
M3x8mm



BAG G

PLASTIC BAG 2

17

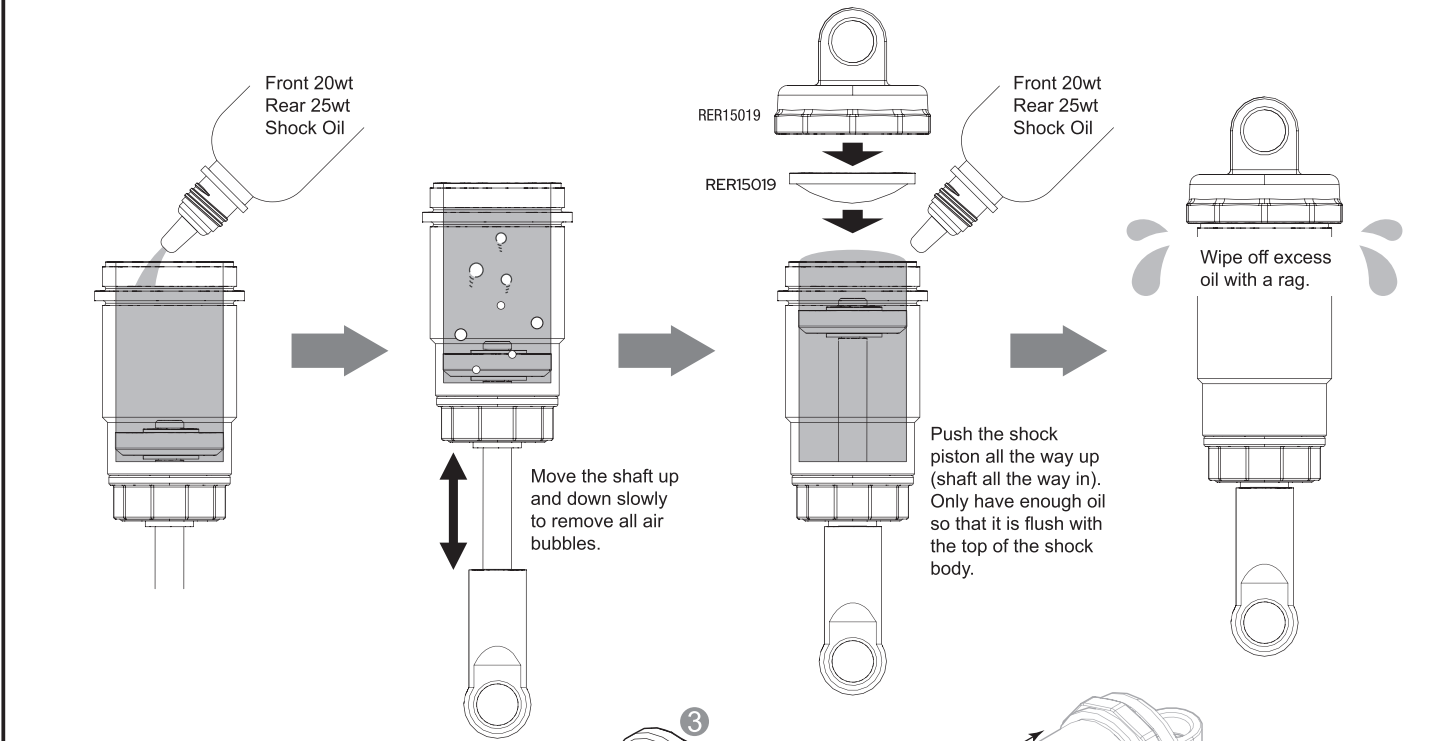
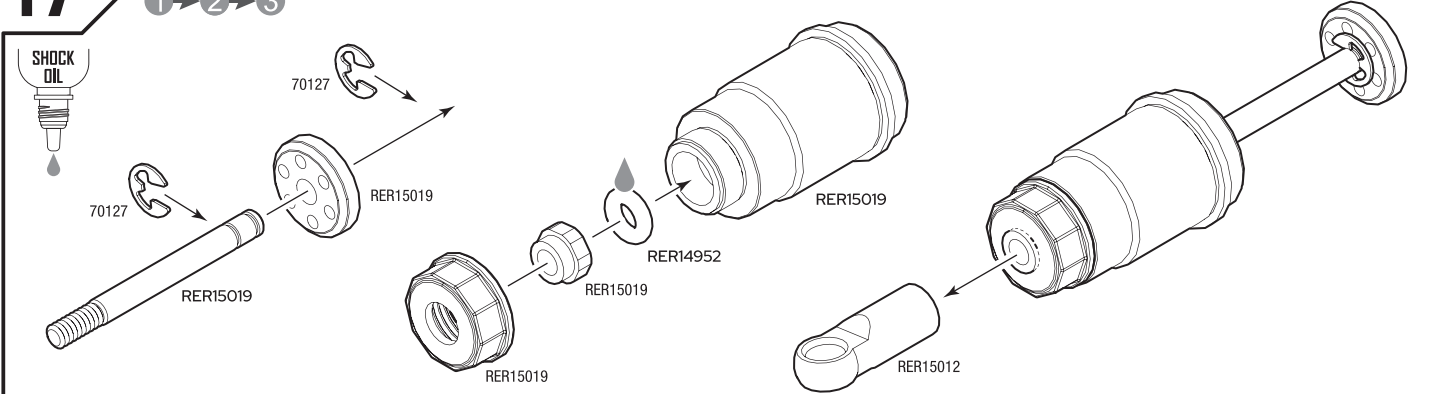
1 → 2 → 3

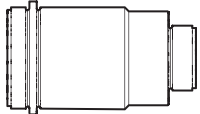
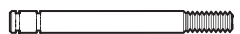

-  RER15019 x 4
-  RER15019 x 4
-  RER15024 x 4
1.3x15x3.2x8.5mm

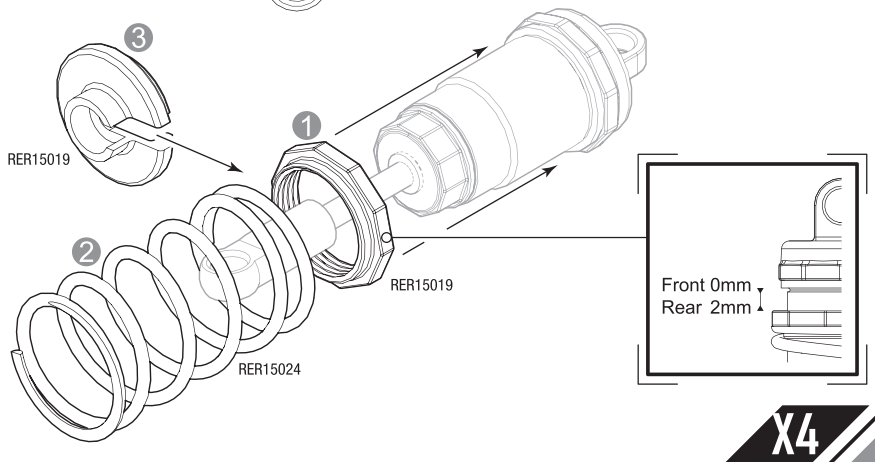

 70127 x 8
2.5mm

18

Front

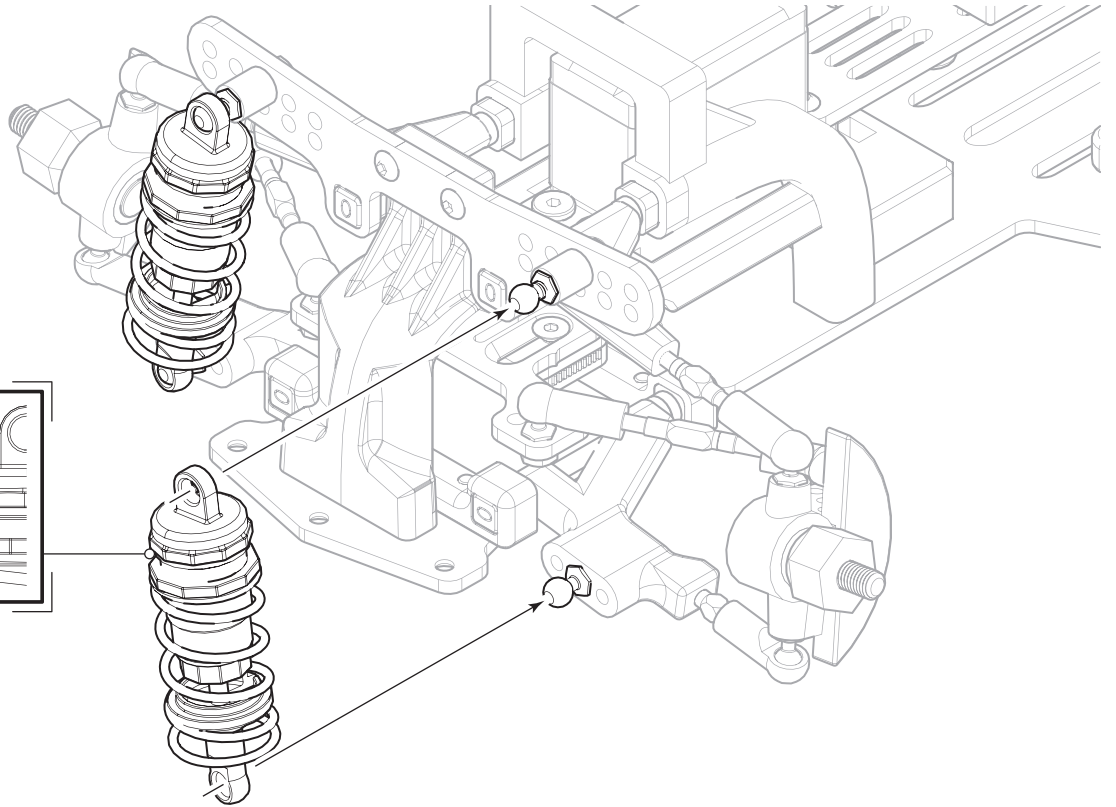
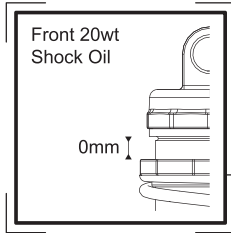

Rear

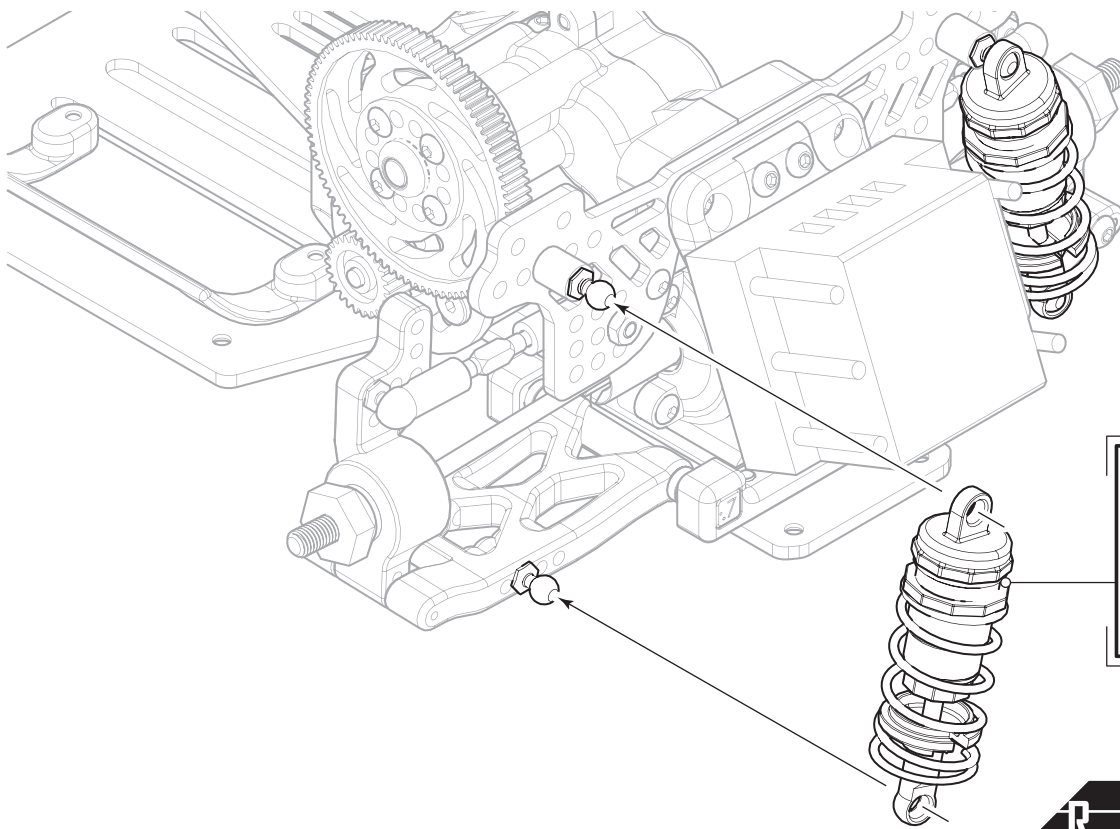
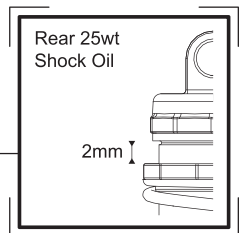

BAG H

PLASTIC BAG 2

19

Front

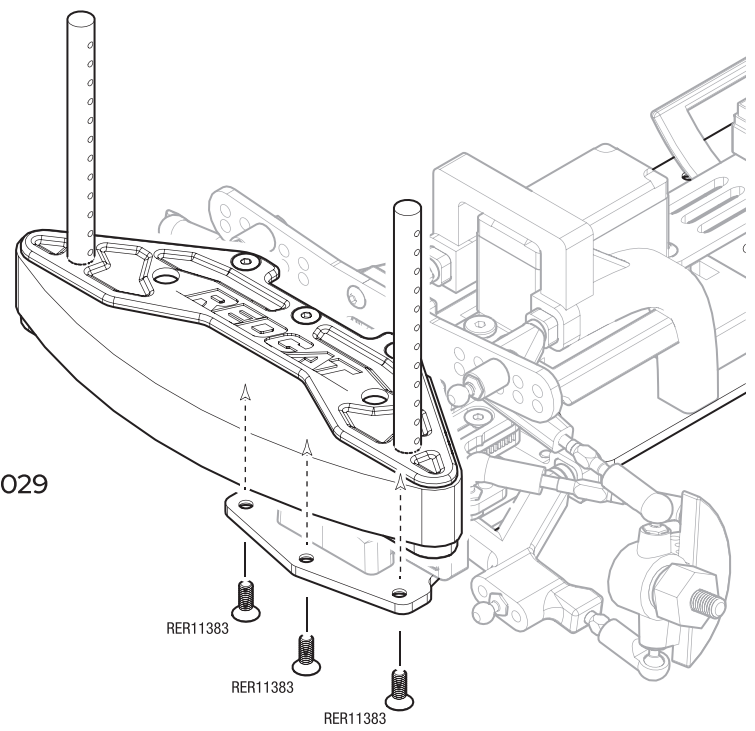
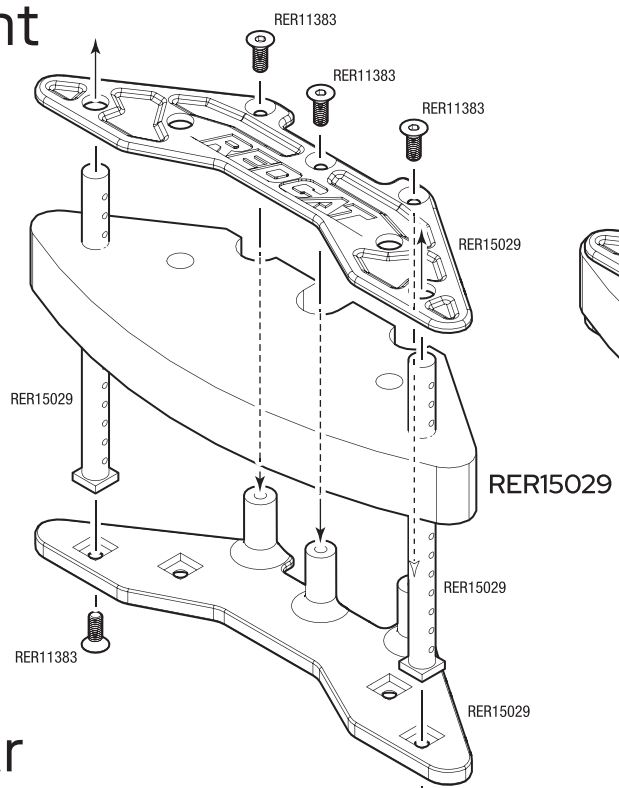

Rear

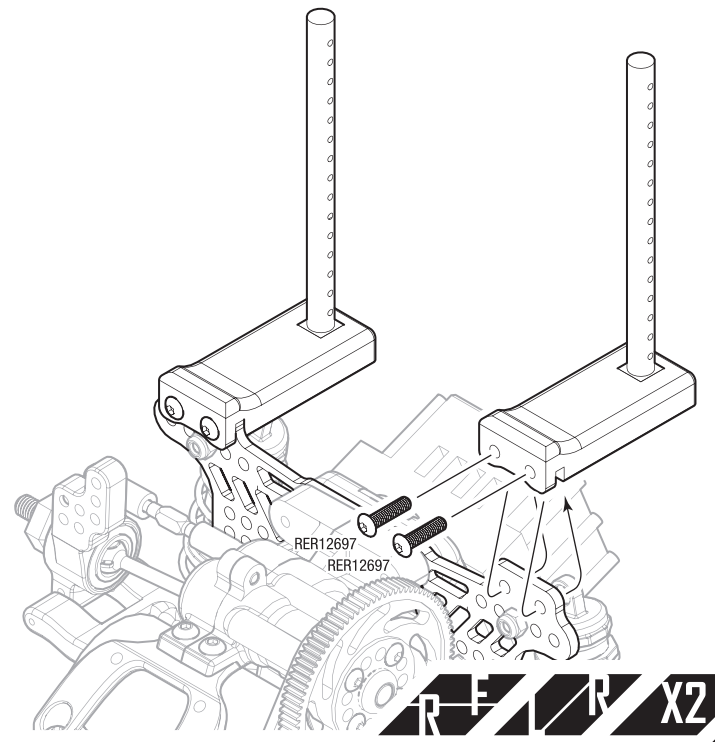
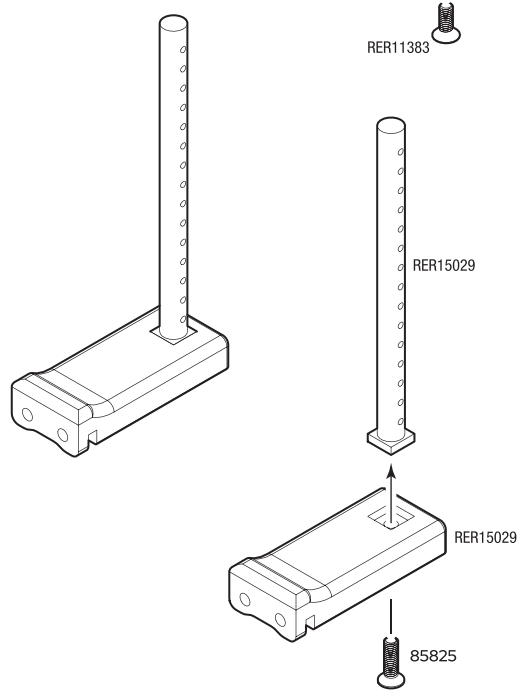

RER12697 x 4
M3x12mm

RER11383 x 8
M3x8mm

85825 x 2
M3x10mm

R E R X2

20

Front

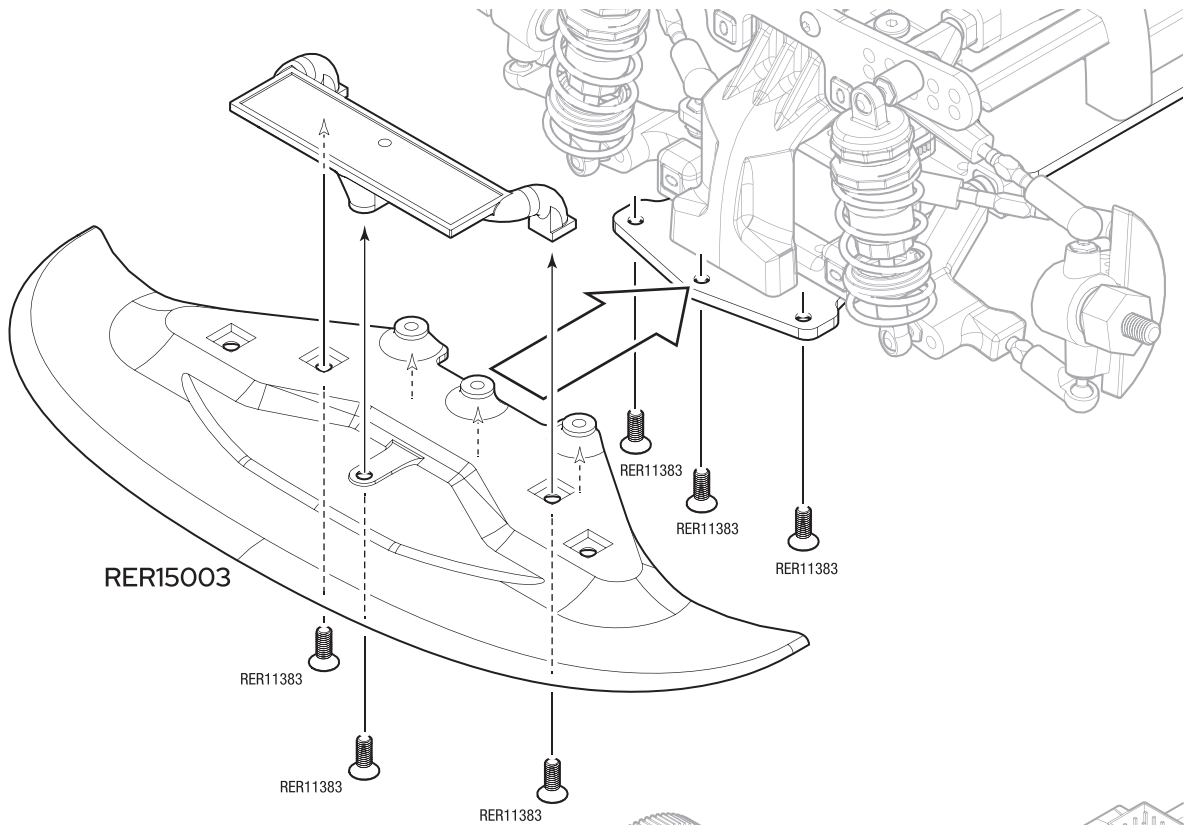

Rear

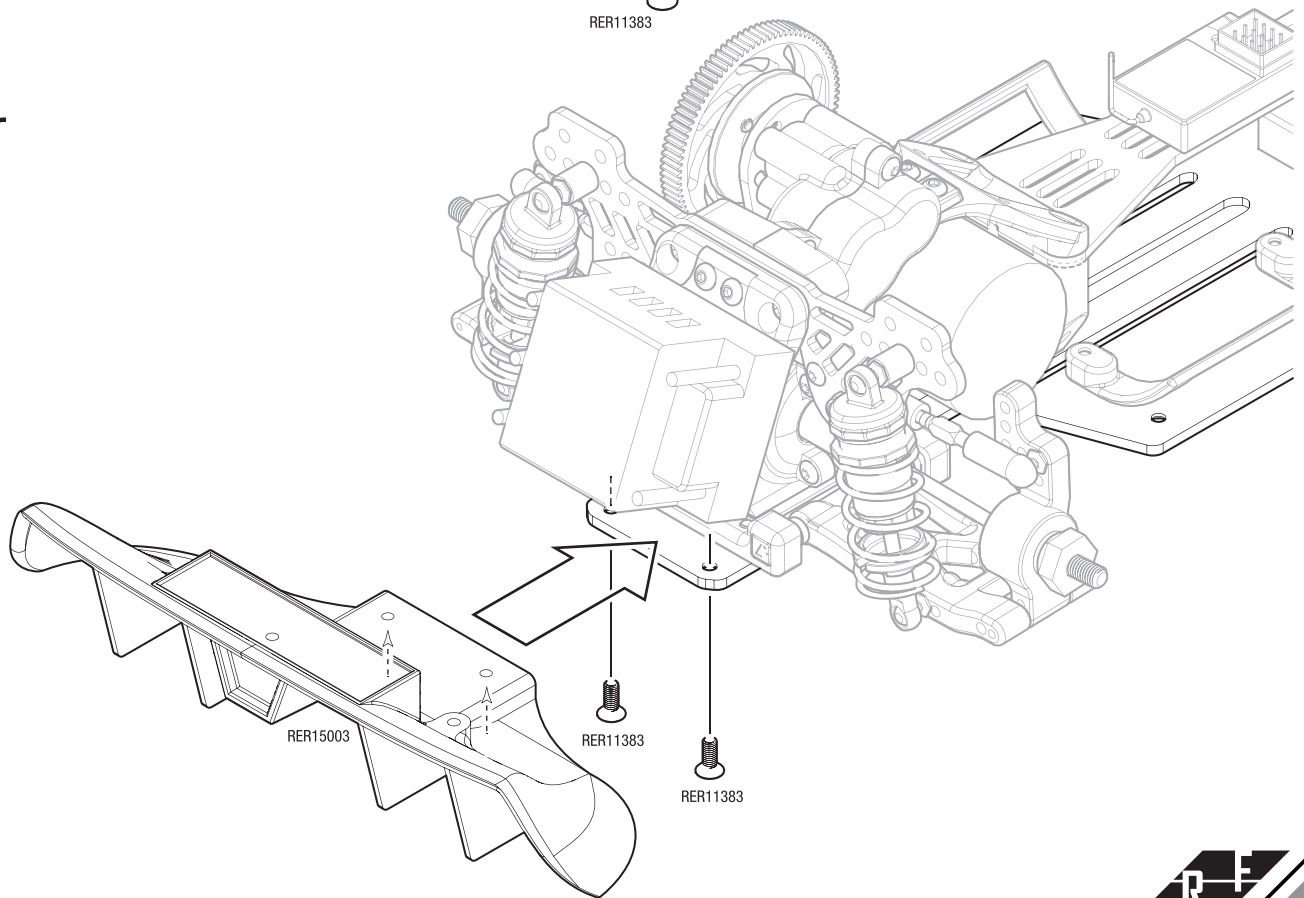

 RER11383 x 8
M3x8mm

21

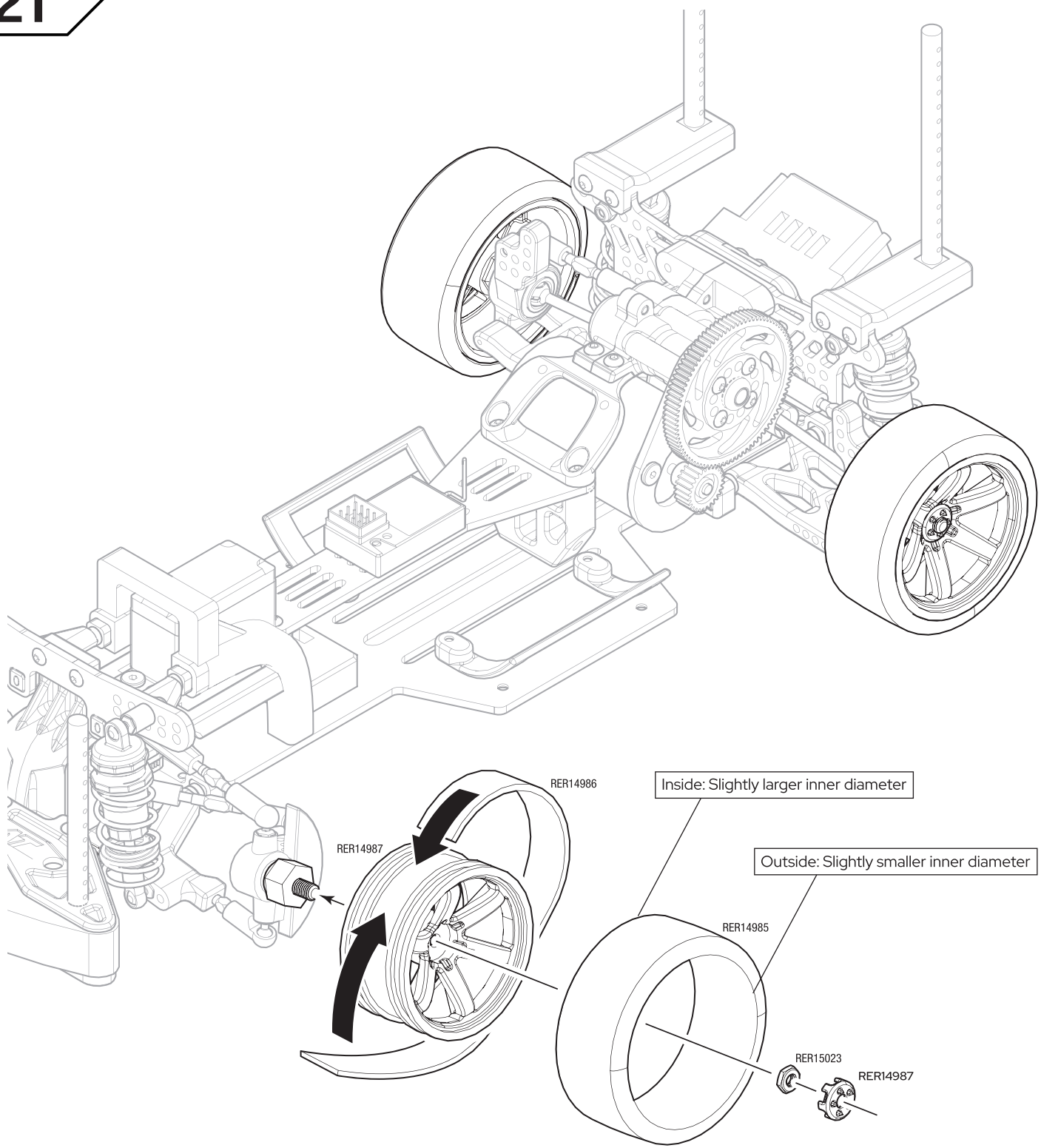

For ease of installation, the inside face of the tire has a slightly larger inner diameter than the outside face. If it is difficult getting the tire started on the rim, try flipping the tire over to see if it will slide on easier.



 RER15023 x 4
M4

Lower Deck & Suspension

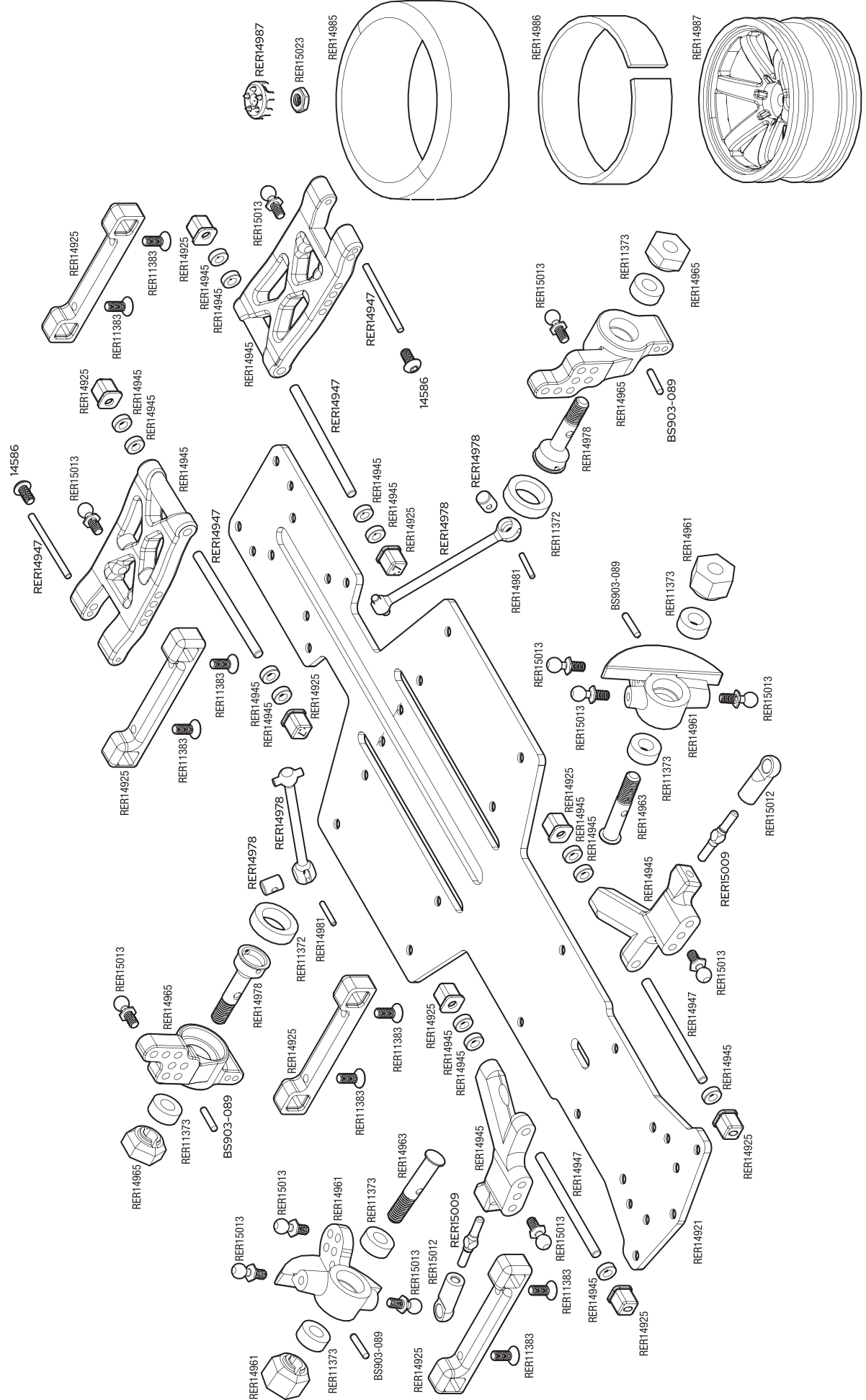

Part Number	Part Description
02098	3x3mm Set Screws Machine Thread(8pcs)
02102	3mm Steel Nylon Insert Locknuts (6pcs)
14586	3x6mm Button Head Hex Machine Thread Screws (8pcs)
70127	2.5mm E-Clips (10pcs)
85825	3x10mm Countersunk Hex Machine Thread Screws (5pcs)
BS903-089	2x10mm Pins (12pcs)
RER11372	10x15x4mm Rubber Sealed Ball Bearings (6pcs)
RER11373	5x10x4mm Rubber Sealed Ball Bearings (6pcs)
RER11375	3x8mm Button Head Hex Machine Thread Screws (10pcs)
RER11383	3x8mm Countersunk Hex Machine Thread Screws (10pcs)
RER12697	3x12mm Button Head Hex Machine Thread Screws (6pcs)
RER12935	3x8mm Flat Head Hex Machine Thread Screws (6pcs)
RER14683	2.6x10mm Button Head Hex Machine Thread Screws (10pcs)
RER14921	Lower Deck(1pc)
RER14922	Upper Deck(1pc)
RER14923	Front Shock Tower(1pc)
RER14924	Rear Shock Tower(1pc)
RER14925	Toe Block Set w/ Inserts(1set)
RER14945	Suspension Arm Set(Plastic)(1set)
RER14947	Suspension Pin Set(1set)
RER14950	Front Bulkhead(1pc)
RER14952	Shock O-Rings(8pcs)
RER14955	Steering Plate(1pc)
RER14956	Servo Horn,Center Mount and Bridge(1set)
RER14961	Front Knuckles and Hex(1pr)
RER14963	Front Axle Set(2pcs)
RER14965	Rear Hubs and Hex (1pr)
RER14967	Gearbox Housing(1set)
RER14974	Spur Gear Hub(1pc)
RER14976	Motor Mount(1pc)
RER14978	CVD Set(2pcs)
RER14981	1/6x9.7mm Pins(2pcs)
RER14985	Drift Tire Set(4pcs)
RER14986	Foam Set(4pcs)
RER14987	1/10 Wheel Set W/ Lug Caps(4pcs)
RER15000	Steel Plate and Magnet(1pr)
RER15003	Rear Diffuser and Front Splitter(1pr)
RER15004	Body Accessories(1set)
RER15009	Turnbuckle Set (Steel)(1set)

Part Number	Part Description
RER15012	Ball Cup Set(16pcs)
RER15013	4.8x6mm Ball Stud(8pcs)
RER15014	4.8x12mm Ball Stud(8pcs)
RER15019	F/R Shocks Complete(4pcs)
RER15023	4mm Nylon Locknut(Thin)(4pc)
RER15024	Spring Set (4pcs)
RER15029	Bumper and Body Post Set(1set)
RER15033	Idler Gear Pins (2pcs)
RER15036	Complete Differential W/ Idler Gears(1set)
RER15044	88T Spur Gear (48P)(1pc)
RER15045	26T Pinion Gear(48p)(1pc)
RER15051	ESC Plate, Magnet Holder, Battery Holder(1set)

Optional Parts

RER15006	540 3300kv Brushless Motor (1pc)
RER15007	GX-1 Drift Gyro (1pc)
RER15008	Hexfly Drift Spec Coreless Digital Servo (1pc)
WP-10BL60-RTR	Hobbywing 60A Brushless Speed Controller (Sensorless) Splashproof (1pc)
RCR-2CENR	Flysky RCR-2CE Radio (2.4Ghz)(1pc)
28480	Receiver (Flysky FS-A3) (Compatible with RCR-2CENR Radio)(1pc)
RER14934	Pre-painted Drift Body Kit (Orange)(1pc)
RER14935	Pre-painted Drift Body Kit (Grey)(1pc)
RER14933	Drift Clear Body Kit (1pc)



Driver:	Location: <input type="checkbox"/> Indoor <input type="checkbox"/> Outdoor
Date: / /	Track Surface: <input type="checkbox"/> P-Tile <input type="checkbox"/> Carpet
Track Name:	<input type="checkbox"/> Polished Concrete <input type="checkbox"/> Asphalt
Track Fee:	<input type="checkbox"/> Unpolished Concrete
Qualified:	Condition: <input type="checkbox"/> Smooth <input type="checkbox"/> Rough
Placed:	Traction: <input type="checkbox"/> High <input type="checkbox"/> Medium <input type="checkbox"/> Low

FRONT

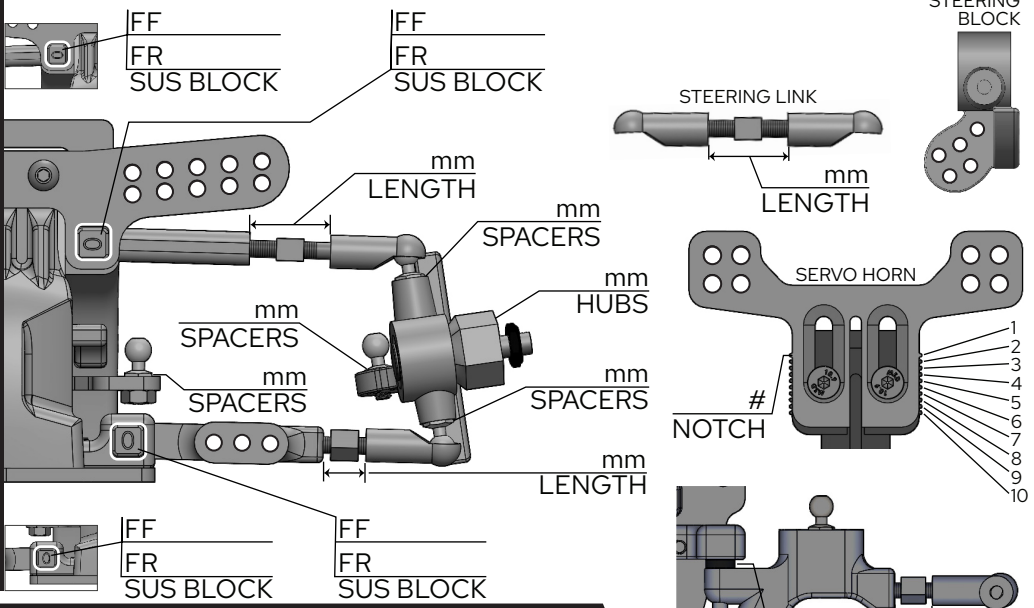

RIDE HEIGHT _____ mm

CAMBER ANGLE _____ mm

CASTER ANGLE _____

DROOP _____ mm

TOE ANGLE _____

NOTES _____

SHOCKS

PRELOAD _____ mm

OIL _____ WT

PISTON _____ HOLES

SPRING _____ mm

O-RINGS (limit shock travel)

NOTES _____

REAR

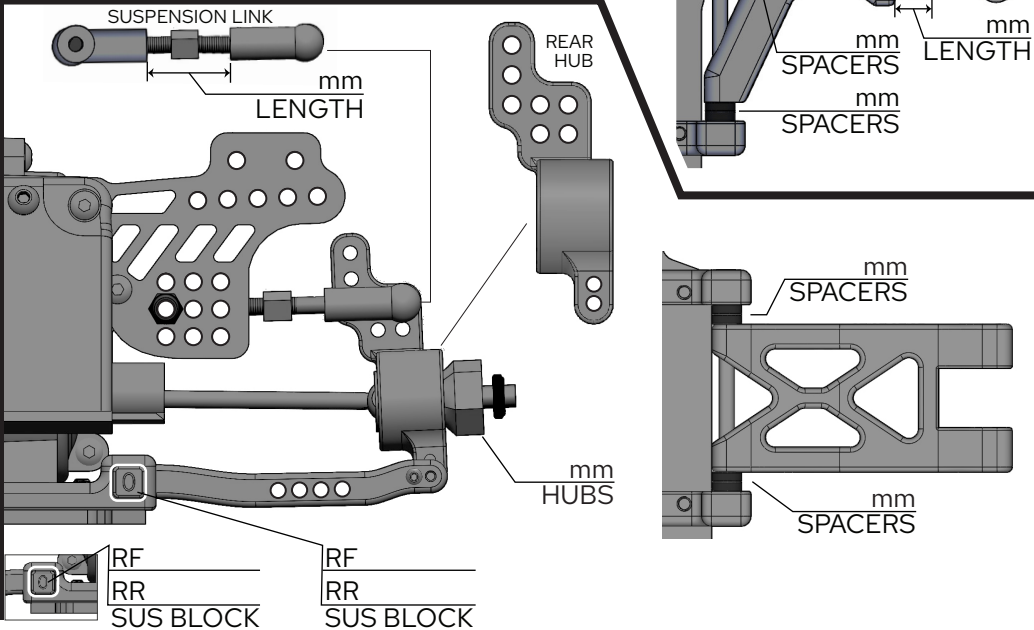

RIDE HEIGHT _____ mm

CAMBER ANGLE _____ mm

CASTER ANGLE _____

DROOP _____ mm

TOE ANGLE _____

NOTES _____

SHOCKS

PRELOAD _____ mm

OIL _____ WT

PISTON _____ HOLES

SPRING _____ mm

O-RINGS (limit shock travel)

NOTES _____

OTHER

SPUR	PINION
BODY	WING
SERVO	ESC
GYRO	GAIN
MOTOR	POSITION
BATTERY	<input type="checkbox"/> FRONT <input type="checkbox"/> MID <input type="checkbox"/> REAR
OTHER	

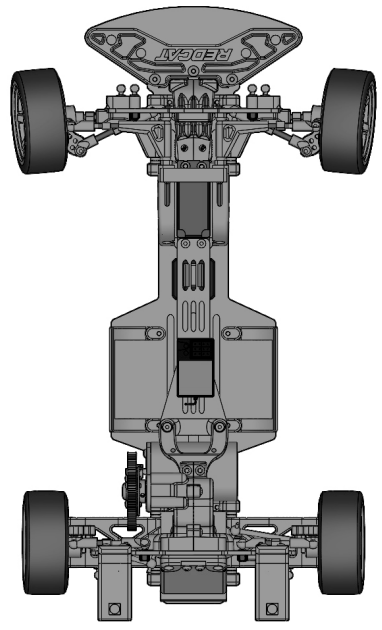

FRONT

TIRE _____

WHEEL _____

OFFSET _____

NOTES _____

REAR

TIRE _____

WHEEL _____

OFFSET _____

NOTES _____



Driver: RTR	Location: <input checked="" type="checkbox"/> Indoor <input type="checkbox"/> Outdoor
Date: / /	Track Surface: <input type="checkbox"/> P-Tile <input type="checkbox"/> Carpet
Track Name: Base Setup	<input checked="" type="checkbox"/> Polished Concrete <input type="checkbox"/> Asphalt
Track Fee:	<input type="checkbox"/> Unpolished Concrete
Qualified:	Condition: <input checked="" type="checkbox"/> Smooth <input type="checkbox"/> Rough
Placed:	Traction: <input type="checkbox"/> High <input type="checkbox"/> Medium <input checked="" type="checkbox"/> Low

FRONT

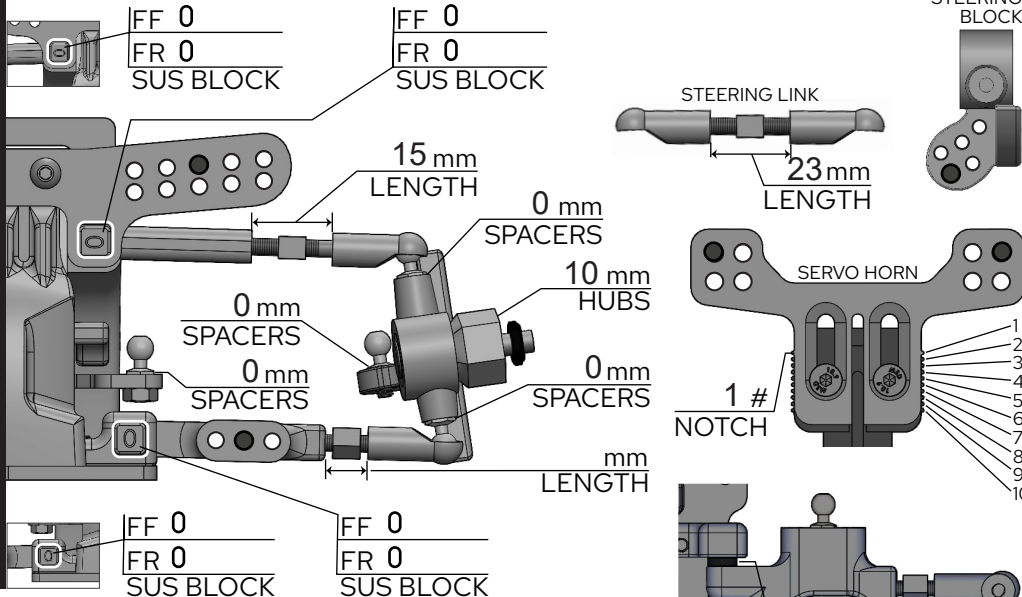

RIDE HEIGHT	18 mm
CAMBER ANGLE	6 deg.
CASTER ANGLE	8 deg.
DROOP	13 mm
TOE ANGLE	4 deg. out
NOTES	

SHOCKS	
PRELOAD	0 mm
OIL	20 WT
PISTON	6 HOLES
SPRING	1.6 mm
O-RINGS (limit shock travel)	0
NOTES	

REAR

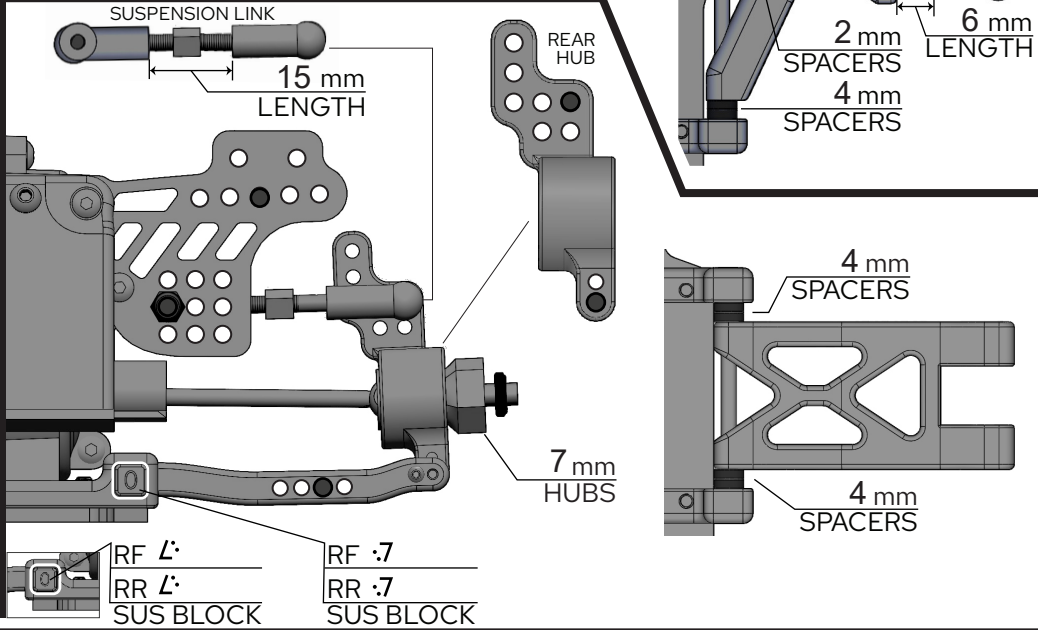

RIDE HEIGHT	9 mm
CAMBER ANGLE	2
CASTER ANGLE	N/A
DROOP	13 mm
TOE ANGLE	2.1
NOTES	

SHOCKS	
PRELOAD	2 mm
OIL	25 WT
PISTON	6 HOLES
SPRING	1.6 mm
O-RINGS (limit shock travel)	0
NOTES	

OTHER

SPUR	PINION
88 Tooth	26 Tooth
BODY	WING
Stock	None
SERVO	ESC
HEXFLY drift-Spec	HOBBYWING WP-10BL60-RTR
GYRO	GAIN
HEXFLY GX-1	48%
MOTOR	POSITION
Redcat 3300Kv	<input type="checkbox"/> FRONT <input type="checkbox"/> MID <input checked="" type="checkbox"/> REAR
BATTERY	
Shorty 2S LIPO	
OTHER	

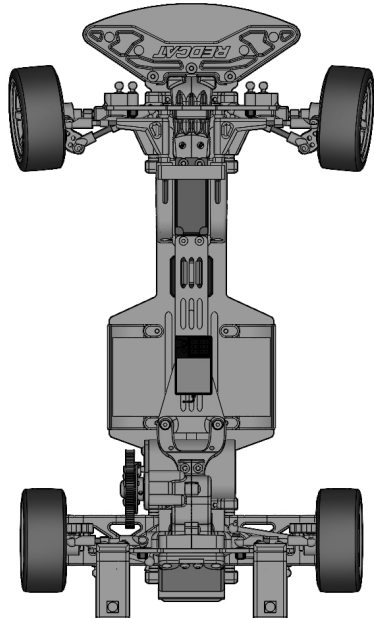

FRONT	
TIRE	Stock
WHEEL	Stock
OFFSET	Stock
NOTES	

REAR	
TIRE	Stock
WHEEL	Stock
OFFSET	Stock
NOTES	

REDCAT RDS TOE BLOCK CHART TOE IS IN DEGREES

		FRONT TOE BLOCK INSERT SETUP								
		FRONT OF HINGEPIN - OUT				CENTERED	FRONT OF HINGEPIN - IN			
		1.1	1	0.7	0.5		0.5	0.7	1	1.1
REAR OF HINGEPIN OUT	1.1	0	-2	-7	-1.	-1.8	-2.6	-2.9	-3.4	-3.6
	1	.2	0	-5	-8	-1.6	-2.5	-2.8	-3.3	-3.4
	0.7	.7	.5	0	-3	-1.2	-2.	-2.3	-2.8	-2.9
	0.5	1.	.8	.3	0	-8	-1.6	-2.	-2.5	-2.6
CENTERED		1.8	1.6	1.2	.8	0	-8	-1.2	-1.6	-1.8
REAR OF HINGEPIN IN	0.5	2.6	2.5	2.	1.6	.8	0	-.3	-.8	-1.
	0.7	2.9	2.8	2.3	2.	1.2	.3	0	-.5	-.7
	1	3.4	3.3	2.8	2.5	1.6	.8	.5	0	-.2
	1.1	3.6	3.4	2.9	2.6	1.8	1.	.7	.2	0

		REAR TOE BLOCK INSERT SETUP								
		FRONT OF HINGEPIN - OUT				CENTERED	FRONT OF HINGEPIN - IN			
		1.1	1	0.7	0.5		0.5	0.7	1	1.1
REAR OF HINGEPIN OUT	1.1	0	-2	-6	-9	-1.7	-2.4	-2.7	-3.2	-3.3
	1	-	0	-5	-8	-1.5	-2.3	-2.6	-3.	-3.2
	0.7	-	-	0	-3	-1.1	-1.8	-2.1	-2.6	-2.7
	0.5	-	-	-	0	-8	-1.5	-1.8	-2.3	-2.4
CENTERED		-	-	-	-	0	-8	-1.1	-1.5	-1.7
REAR OF HINGEPIN IN	0.5	-	-	-	-	-	0	-.3	-.8	-.9
	0.7	-	-	-	-	-	-	0	-.5	-.6
	1	-	-	-	-	-	-	-	0	-.2
	1.1	-	-	-	-	-	-	-	-	0

ANGLE OF TOE

REDCAT RDS - GEAR RATIO CHART

		RTR/Kit Spec												
		70	72	74	76	78	80	82	84	86	88	90	92	94
15	12.13	12.48	12.83	13.17	13.52	13.87	14.21	14.56	14.91	15.25	15.60	15.95	16.29	16.64
16	11.38	11.70	12.03	12.35	12.68	13.00	13.33	13.65	13.98	14.30	14.63	14.95	15.28	15.60
17	10.71	11.01	11.32	11.62	11.93	12.24	12.54	12.85	13.15	13.46	13.76	14.07	14.38	14.68
18	10.11	10.40	10.69	10.98	11.27	11.56	11.84	12.13	12.42	12.71	13.00	13.29	13.58	13.87
19	9.58	9.85	10.13	10.40	10.67	10.95	11.22	11.49	11.77	12.04	12.32	12.59	12.86	13.14
20	9.10	9.36	9.62	9.88	10.14	10.40	10.66	10.92	11.18	11.44	11.70	11.96	12.22	12.48
21	8.67	8.91	9.16	9.41	9.66	9.90	10.15	10.40	10.65	10.90	11.14	11.39	11.64	11.89
22	8.27	8.51	8.75	8.98	9.22	9.45	9.69	9.93	10.16	10.40	10.64	10.87	11.11	11.35
23	7.91	8.14	8.37	8.59	8.82	9.04	9.27	9.50	9.72	9.95	10.17	10.40	10.63	10.85
24	7.58	7.80	8.02	8.23	8.45	8.67	8.88	9.10	9.32	9.53	9.75	9.97	10.18	10.40
25	7.28	7.49	7.70	7.90	8.11	8.32	8.53	8.74	8.94	9.15	9.36	9.57	9.78	9.98
26	7.00	7.20	7.40	7.60	7.80	8.00	8.20	8.40	8.60	8.80	9.00	9.20	9.40	9.60
27	6.74	6.93	7.13	7.32	7.51	7.70	7.90	8.09	8.28	8.47	8.67	8.86	9.05	9.24
28	6.50	6.69	6.87	7.06	7.24	7.43	7.61	7.80	7.99	8.17	8.36	8.54	8.73	8.91
29	6.28	6.46	6.63	6.81	6.99	7.17	7.35	7.53	7.71	7.89	8.07	8.25	8.43	8.61
30	6.07	6.24	6.41	6.59	6.76	6.93	7.11	7.28	7.45	7.63	7.80	7.97	8.15	8.32
31	5.87	6.04	6.21	6.37	6.54	6.71	6.88	7.05	7.21	7.38	7.55	7.72	7.88	8.05
32	5.69	5.85	6.01	6.18	6.34	6.50	6.66	6.83	6.99	7.15	7.31	7.48	7.64	7.80
33	5.52	5.67	5.83	5.99	6.15	6.30	6.46	6.62	6.78	6.93	7.09	7.25	7.41	7.56
34	5.35	5.51	5.66	5.81	5.96	6.12	6.27	6.42	6.58	6.73	6.88	7.04	7.19	7.34
35	5.20	5.35	5.50	5.65	5.79	5.94	6.09	6.24	6.39	6.54	6.69	6.83	6.98	7.13
36	5.06	5.20	5.34	5.49	5.63	5.78	5.92	6.07	6.21	6.36	6.50	6.64	6.79	6.93
37	4.92	5.06	5.20	5.34	5.48	5.62	5.76	5.90	6.04	6.18	6.32	6.46	6.61	6.75
38	4.79	4.93	5.06	5.20	5.34	5.47	5.61	5.75	5.88	6.02	6.16	6.29	6.43	6.57
39	4.67	4.80	4.93	5.07	5.20	5.33	5.47	5.60	5.73	5.87	6.00	6.13	6.27	6.40
40	4.55	4.68	4.81	4.94	5.07	5.20	5.33	5.46	5.59	5.72	5.85	5.98	6.11	6.24
41	4.44	4.57	4.69	4.82	4.95	5.07	5.20	5.33	5.45	5.58	5.71	5.83	5.96	6.09
42	4.33	4.46	4.58	4.70	4.83	4.95	5.08	5.20	5.32	5.45	5.57	5.70	5.82	5.94
43	4.23	4.35	4.47	4.60	4.72	4.84	4.96	5.08	5.20	5.32	5.44	5.56	5.68	5.80
44	4.14	4.25	4.37	4.49	4.61	4.73	4.85	4.96	5.08	5.20	5.32	5.44	5.55	5.67
45	4.04	4.16	4.28	4.39	4.51	4.62	4.74	4.85	4.97	5.08	5.20	5.32	5.43	5.55
46	3.96	4.07	4.18	4.30	4.41	4.52	4.63	4.75	4.86	4.97	5.09	5.20	5.31	5.43
47	3.87	3.98	4.09	4.20	4.31	4.43	4.54	4.65	4.76	4.87	4.98	5.09	5.20	5.31







Follow us on social media

Take a photo, create a video, post and share your Redcat experience.

Stay up to date on the latest Redcat news, products, and creative content. While these profiles are not customer service channels, you might find that one of our subject experts or another member of the community is able to assist you. If you have an issue or need technical and or product support, please reach out to Redcat directly through our website.



-  <https://www.facebook.com/RedcatRacing>
-  <https://www.instagram.com/RedcatRacing>
-  <https://www.youtube.com/RedcatRacing>
-  <https://www.twitter.com/RedcatRacing>
-  <https://www.pinterest.com/RedcatRacing>

Link to the most recent version of this manual with driving tips, setup suggestions and setup sheets: <https://www.redcatracing.com/pages/manuals>