



LANDSLIDE XTE

MANUAL / QUICK START GUIDE

IMPORTANT LINKS:

Link to the most recent version of this manual with exploded views and parts lists:
<https://www.redcatracing.com/pages/manuals>

Link to electric vehicles manual:
www.redcatracing.com/manuals/ELECTRIC-MANUAL.pdf



FEATURES & SPECIFICATIONS

- Brushless Electric Motor
- Brushless 120A ESC
- Forward & Reverse
- 4 Wheel Drive
- Aluminum Capped Oil Filled Big Bore Shocks
- 2.4GHz Radio System

- Scale: 1/8
- Length: 510mm
- Width: 380mm
- Height: 250mm
- Wheelbase: 325mm
- Ground Clearance: 58mm

Vehicle Battery Capabilities
 Minimum LIPO voltage: 11.1V
 Maximum LIPO voltage: 14.4V

Warning: Exceeding the maximum battery voltage may cause damage to the motor and electronic components of this vehicle and will void the vehicle warranty.

VEHICLE OVERVIEW

- A:** On/Off Switch
- B:** 2.4GHz Receiver
- C:** ESC
- D:** Electric Motor
- E:** Steering Servo
- F:** Steering Linkage
- G:** Upper Suspension Link
- H:** Oil Filled Shocks
- I:** Battery Boxes
- J:** Battery Straps

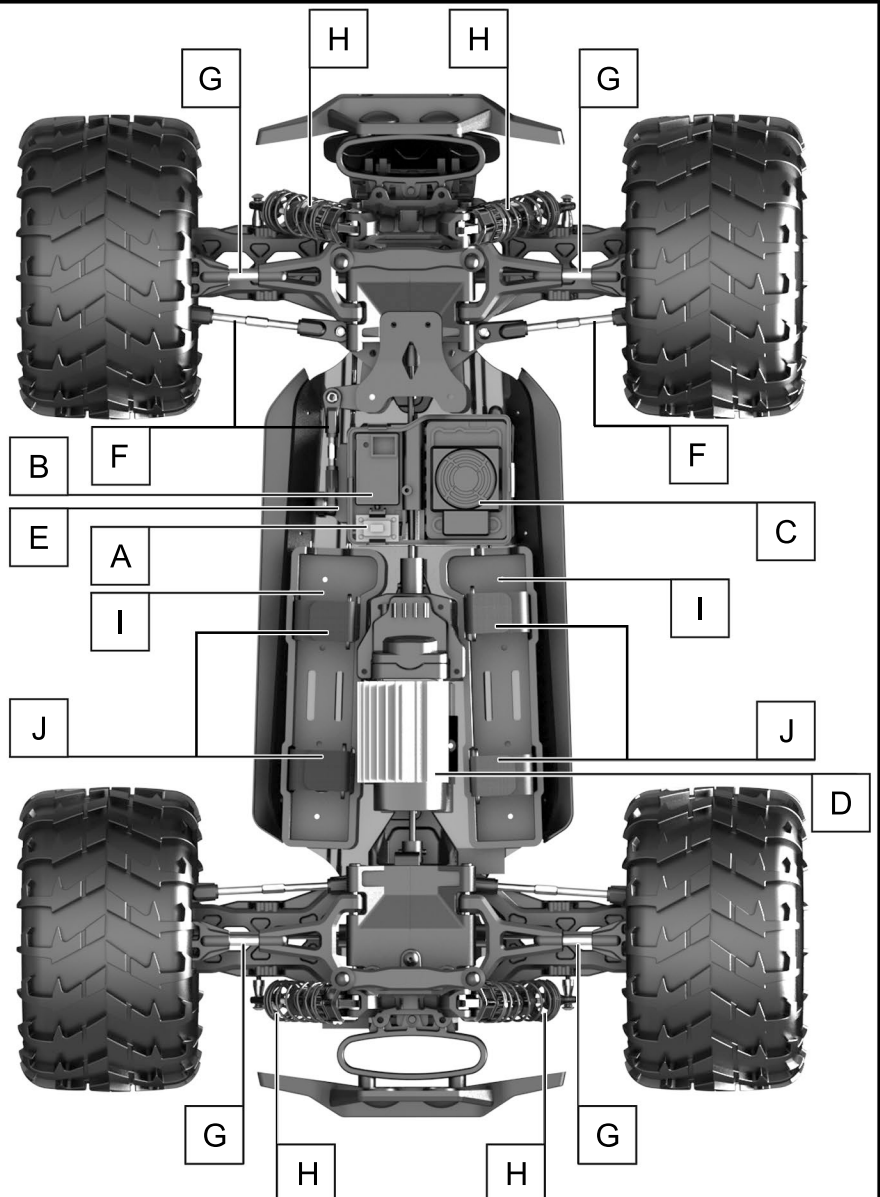

RADIO GUIDE

RCR-2CENR
 2.4 GHZ RADIO

CONTROL PANEL

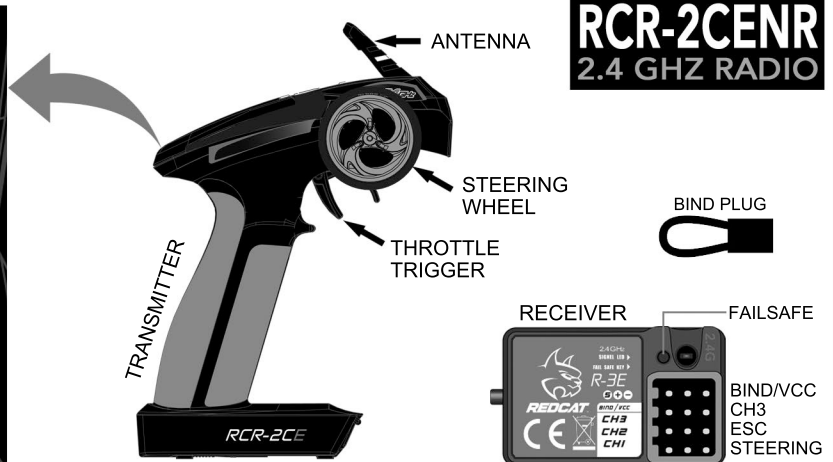
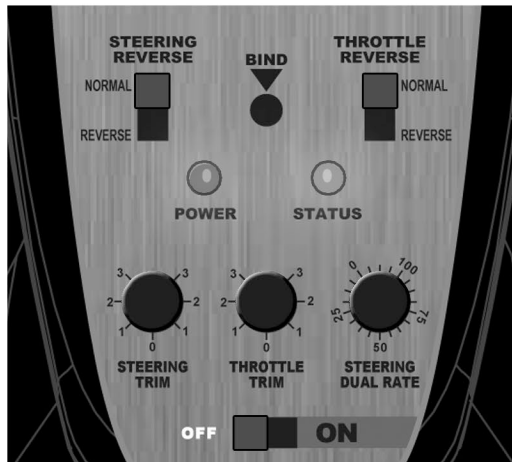

RADIO:

Steering Reverse Switch: Top left switch. Used to change steering orientation. If the car turns right when you steer left, flip this switch.

Throttle Reverse Switch: Top right switch. Used to change throttle trigger orientation. If the car goes in reverse while you pull the throttle trigger, flip this switch.

Power LED: Left LED light. Lights up when the transmitter is turned on.

Status LED: Right LED light. Lights up green when transmitter batteries are full. Flashes when transmitter batteries are low and need replacing.

Bind Button: Used to bind the transmitter to the receiver. See binding instructions.

Steering Trim: Left knob. Used to set the steering neutral point. If the vehicle veers in one direction while the steering wheel is centered, turn this knob in the opposite direction until the car drives straight.

Throttle Trim: Middle knob. Used to set the throttle neutral point. If the vehicle moves forward or reverse while the throttle trigger is centered, turn this knob until the vehicle remains still. For maximum setting, turn slowly until the vehicle creeps forward, then turn the knob the opposite direction until the car stops.

Steering Dual Rate: Right knob. Used to limit the amount of steering. 0= little/no steering & 100= maximum steering. Set the knob to the amount of steering you feel comfortable with. If the vehicle has a tendency to spin out, lower the steering rate.

On/Off Switch: Bottom switch. Turns transmitter On and Off.

RECEIVER:

BIND/VCC: Used when binding to transmitter.

Ch3: Used for 3rd channel when needed.

Ch2: Used for electronic speed controller (ESC).

Ch1: Used for steering servo.

Failsafe Button: Used to set failsafe.

BINDING:

1. Insert the BIND PLUG into the receiver BIND port.
2. Make sure your ESC is plugged into CH2, and insert the bind plug into BIND/VCC. Now, power the vehicle on and the receiver light should begin to blink red.
3. Press the BIND button in the center of the transmitter's Control Panel and turn on radio.
4. Release the bind button when you see the green light on the radio flashing. At this point, your receiver's LED should now be solid red. Turn off the power to your vehicle, as well as the radio.
5. Remove the BIND PLUG from the receiver. Make sure the servos and ESC are attached as described above.
6. First turn your radio on, then your vehicle as normal. Your radio and receiver should be bound together and communicating with each other.

CHARGING BATTERIES

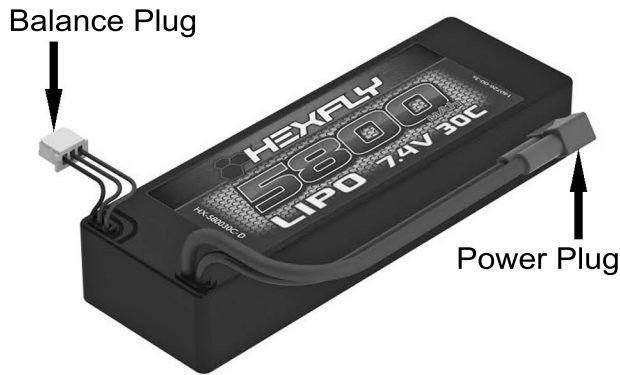

Batteries and charger not included

ATTENTION:

It is important to read all instructions included with your battery and charger before attempting to charge a battery. Follow all instructions and warnings included with your battery and charger when using batteries.

LIPO Balance Plug: This plug **MUST** be plugged into a LIPO balance charger to charge your LIPO battery. Never attempt to quick charge LIPO batteries using the power plug.

Power Plug: This plug is used to power the vehicle and gets plugged into the ESC. On a LIPO battery, Make sure to unplug this plug from the ESC **BEFORE** plugging the Balance Plug into a charger.

Battery Connection Instructions: Make sure battery connectors are fully pushed in when connecting the battery to the vehicle.

ATTENTION:

We recommend you only use quality batteries and chargers like Hexfly batteries and chargers in Redcat vehicles.

Recommended Charger:
HX-403 - LIPO balance charger

Recommended Batteries:
HX-580030C-D - Hexfly 5800MAH 7.4V 30C LIPO battery.

Charge Times:

Charge times vary according to charger current and battery mAh. **Battery mAh ÷ Charger mA = Approximate charge time**
Ex. 2000mAh battery ÷ 500 mA charger = ~4 hours charge time.

To convert milliamps (mA) to amps (A):
Divide the mA number by 1000.
ex. 900mA ÷ 1000 = 0.9A

BATTERY / CHARGER	3200mAh	3500mAh	5000mAh	5800mAh
0.9 A	3.55 hrs	3.88 hrs	5.55 hrs	6.44 hrs
1.5 A	2.13 hrs	2.33 hrs	3.33 hrs	3.87 hrs
3.0 A	1.07 hrs	1.17 hrs	1.67 hrs	1.93hrs

STOP WARNING STOP

UNPLUG THE BATTERY PACK FROM THE VEHICLE! BEFORE CHARGING YOUR BATTERY PACK, YOU MUST FIRST UNPLUG IT FROM THE ESC. FAILURE TO UNPLUG THE BATTERY FROM THE VEHICLE'S ESC BEFORE CHARGING MAY PERMANENTLY DAMAGE SOME OR ALL ELECTRONICS IN THE VEHICLE.

NEVER LEAVE BATTERY PACKS UNATTENDED WHILE CHARGING! Leaving a battery unattended while charging may result in fire and damage / injury.

NEVER ALLOW A BATTERY PACK TO GET HOT! It's normal for the battery pack to get warm, but it should never get hot! Monitor batteries during charging and unplug to let cool if the battery gets hot.

WHEN CHARGING LIPOs, A LIPO SAFE CHARGING BAG SHOULD BE USED TO HELP PREVENT FIRES.

EXPLODED VIEW

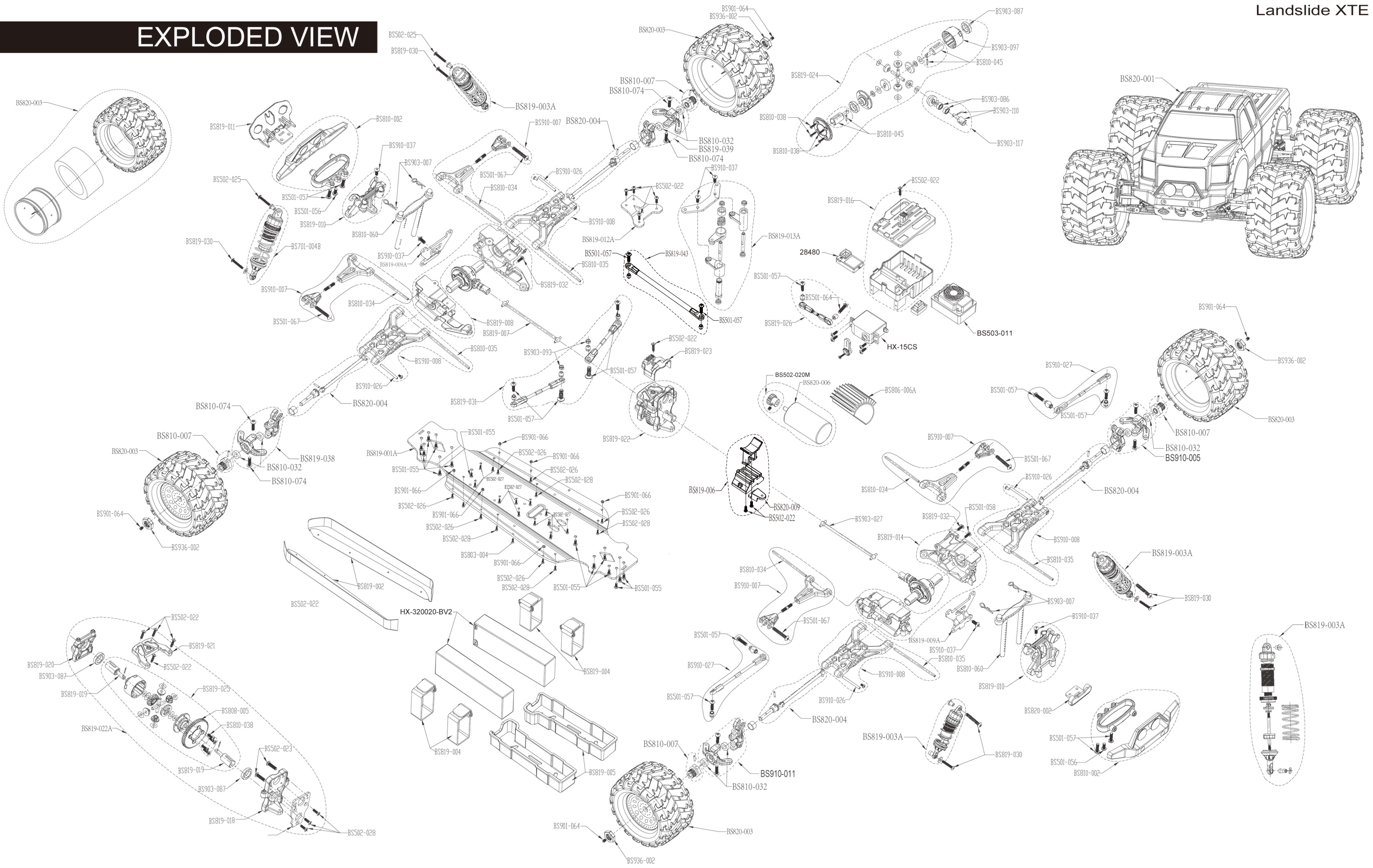

PARTS IDENTIFICATION

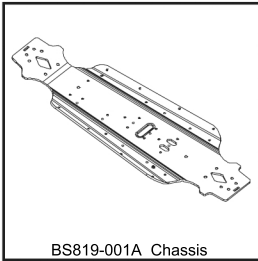

BS819-001A Chassis

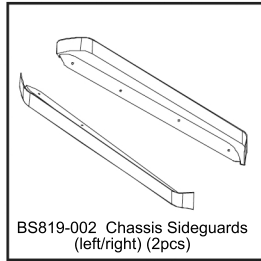

BS819-002 Chassis Sideguards (left/right) (2pcs)

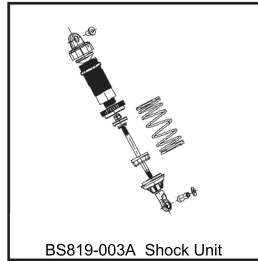

BS819-003A Shock Unit

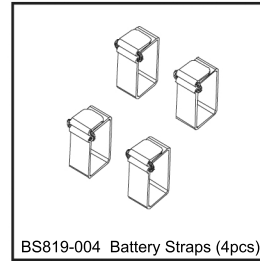

BS819-004 Battery Straps (4pcs)

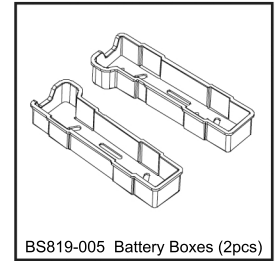

BS819-005 Battery Boxes (2pcs)

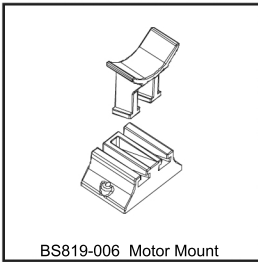

BS819-006 Motor Mount

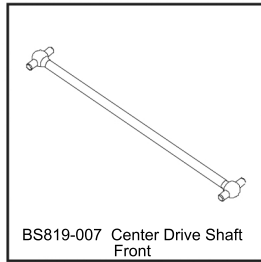

BS819-007 Center Drive Shaft Front

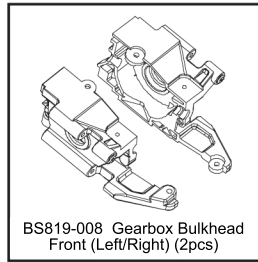

BS819-008 Gearbox Bulkhead Front (Left/Right) (2pcs)

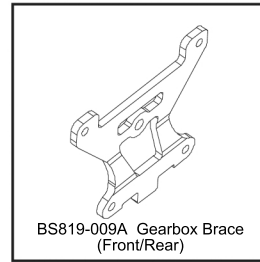

BS819-009A Gearbox Brace (Front/Rear)

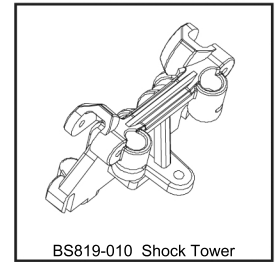

BS819-010 Shock Tower

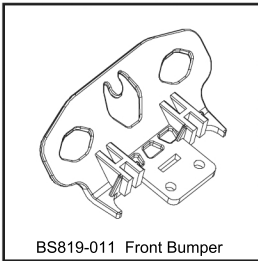

BS819-011 Front Bumper

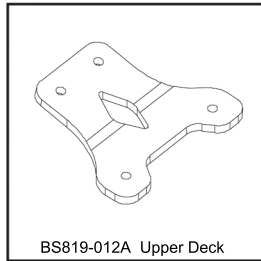

BS819-012A Upper Deck

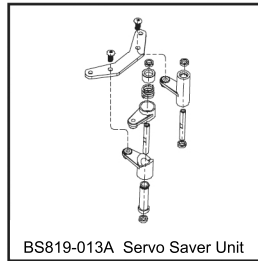

BS819-013A Servo Saver Unit

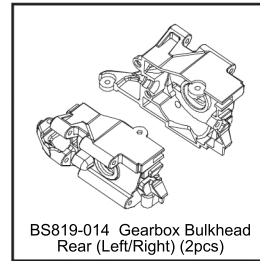

BS819-014 Gearbox Bulkhead Rear (Left/Right) (2pcs)

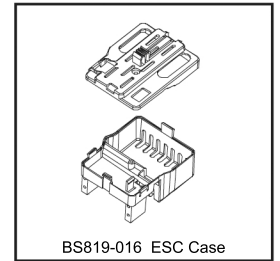

BS819-016 ESC Case

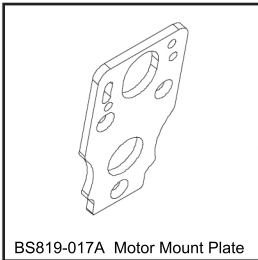

BS819-017A Motor Mount Plate

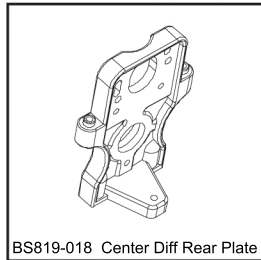

BS819-018 Center Diff Rear Plate

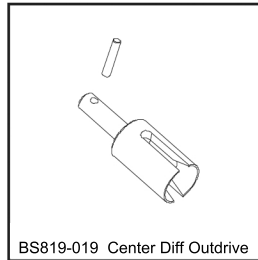

BS819-019 Center Diff Outdrive

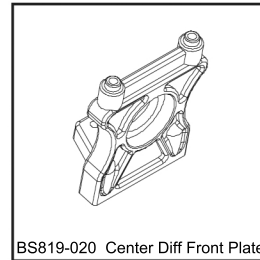

BS819-020 Center Diff Front Plate

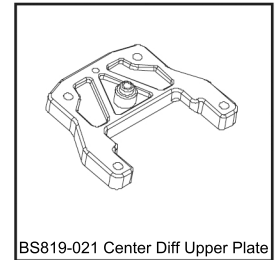

BS819-021 Center Diff Upper Plate

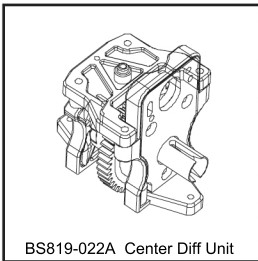

BS819-022A Center Diff Unit

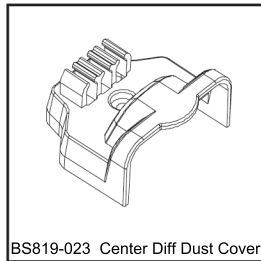

BS819-023 Center Diff Dust Cover

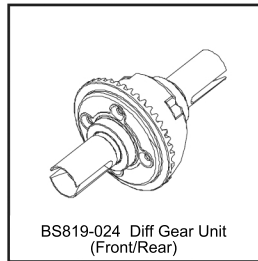

BS819-024 Diff Gear Unit (Front/Rear)

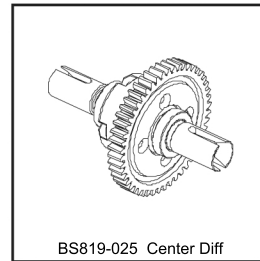

BS819-025 Center Diff



BS819-026 Steering Servo Link

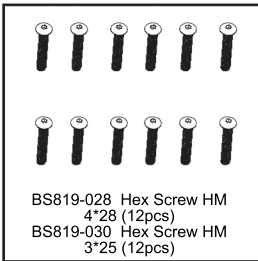

BS819-028 Hex Screw HM 4*28 (12pcs)
BS819-030 Hex Screw HM 3*25 (12pcs)

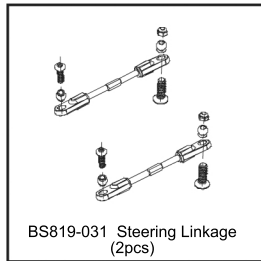

BS819-031 Steering Linkage (2pcs)

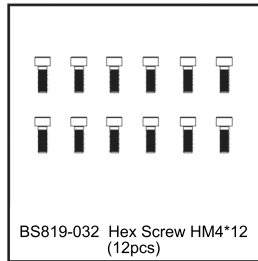

BS819-032 Hex Screw HM4*12 (12pcs)

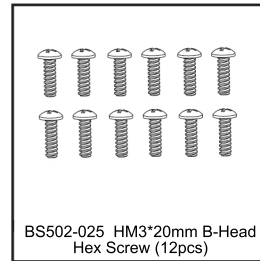

BS502-025 HM3*20mm B-Head Hex Screw (12pcs)

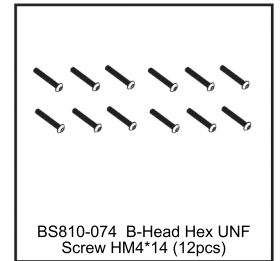

BS810-074 B-Head Hex UNF Screw HM4*14 (12pcs)

PARTS IDENTIFICATION

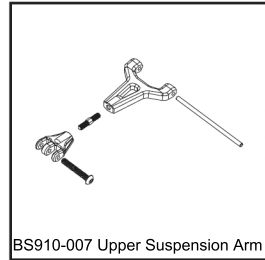

BS910-007 Upper Suspension Arm

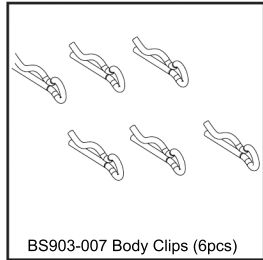

BS903-007 Body Clips (6pcs)

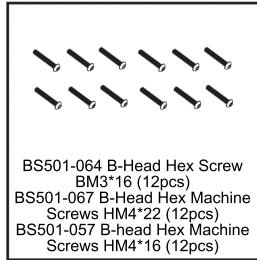

BS501-064 B-Head Hex Screw
BM3*16 (12pcs)
BS501-067 B-Head Hex Machine
Screws HM4*22 (12pcs)
BS501-057 B-head Hex Machine
Screws HM4*16 (12pcs)

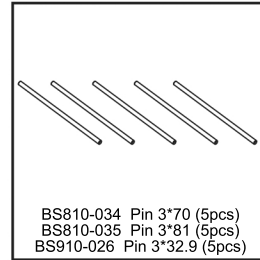

BS810-034 Pin 3*70 (5pcs)
BS810-035 Pin 3*81 (5pcs)
BS910-026 Pin 3*32.9 (5pcs)

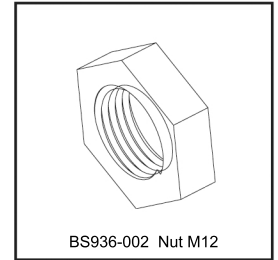

BS936-002 Nut M12

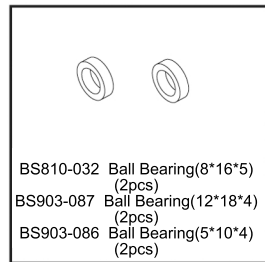

BS810-032 Ball Bearing (8*16*5)
(2pcs)
BS903-087 Ball Bearing (12*18*4)
(2pcs)
BS903-086 Ball Bearing (5*10*4)
(2pcs)

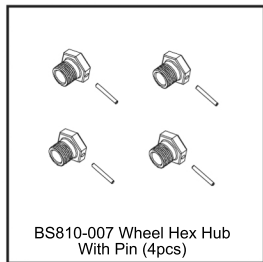

BS810-007 Wheel Hex Hub
With Pin (4pcs)

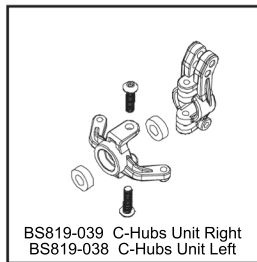

BS819-039 C-Hubs Unit Right
BS819-038 C-Hubs Unit Left

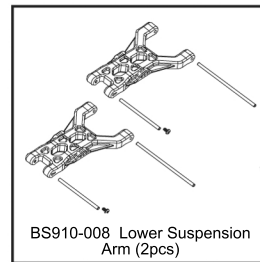

BS910-008 Lower Suspension
Arm (2pcs)

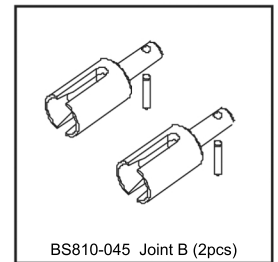

BS810-045 Joint B (2pcs)

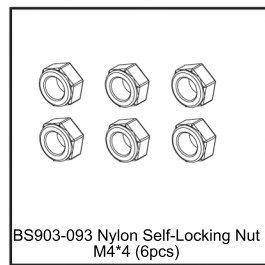

BS903-093 Nylon Self-Locking Nut
M4*4 (6pcs)

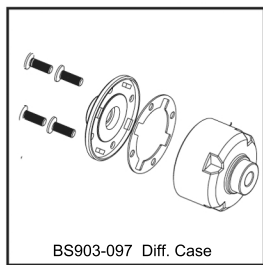

BS903-097 Diff. Case

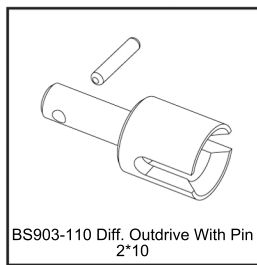

BS903-110 Diff. Outdrive With Pin
2*10

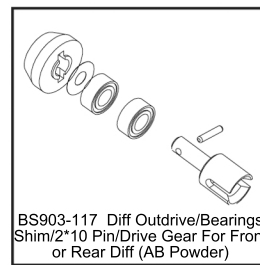

BS903-117 Diff Outdrive/Bearings
Shim/2*10 Pin/Drive Gear For Front
or Rear Diff (AB Powder)

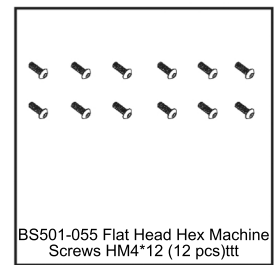

BS501-055 Flat Head Hex Machine
Screws HM4*12 (12 pcs)

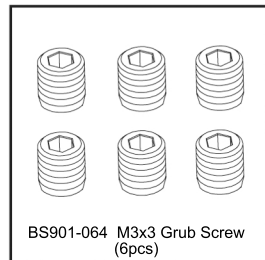

BS901-064 M3x3 Grub Screw
(6pcs)

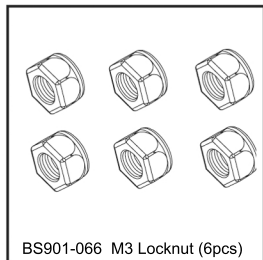

BS901-066 M3 Locknut (6pcs)

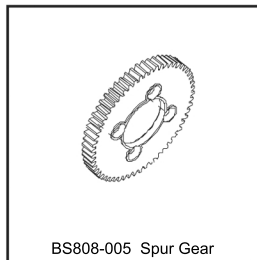

BS808-005 Spur Gear

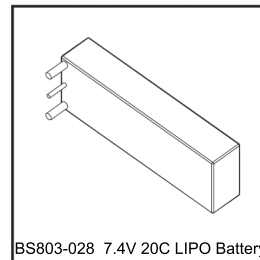

BS803-028 7.4V 20C LIPO Battery

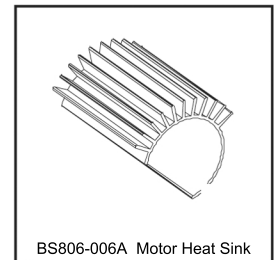

BS806-006A Motor Heat Sink

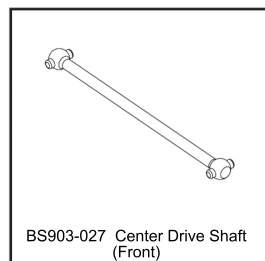

BS903-027 Center Drive Shaft
(Front)

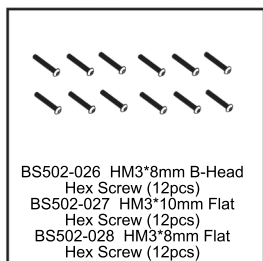

BS502-026 HM3*8mm B-Head
Hex Screw (12pcs)
BS502-027 HM3*10mm Flat
Hex Screw (12pcs)
BS502-028 HM3*8mm Flat
Hex Screw (12pcs)

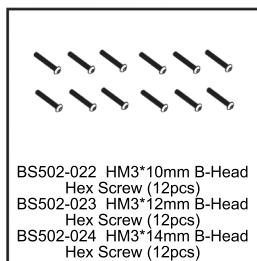

BS502-022 HM3*10mm B-Head
Hex Screw (12pcs)
BS502-023 HM3*12mm B-Head
Hex Screw (12pcs)
BS502-024 HM3*14mm B-Head
Hex Screw (12pcs)

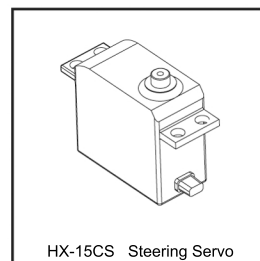

HX-15CS Steering Servo

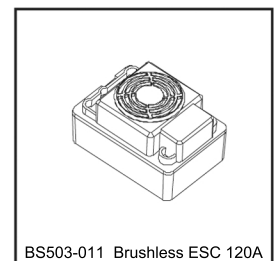

BS503-011 Brushless ESC 120A

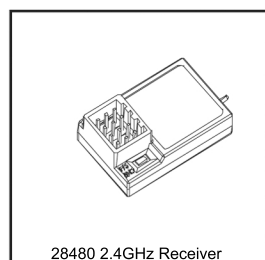

28480 2.4GHz Receiver



RCR-2CENR 2.4GHz Radio
Transmitter

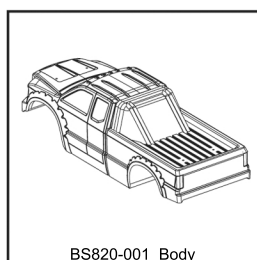

BS820-001 Body

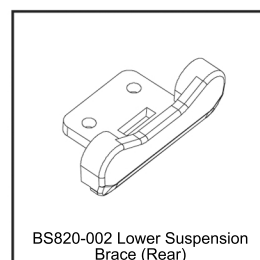

BS820-002 Lower Suspension
Brace (Rear)

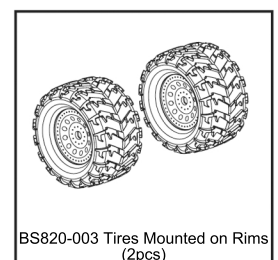

BS820-003 Tires Mounted on Rims
(2pcs)

PARTS IDENTIFICATION

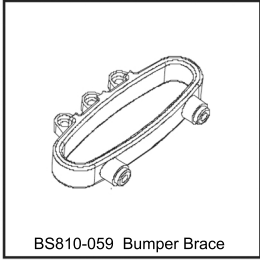

BS810-059 Bumper Brace

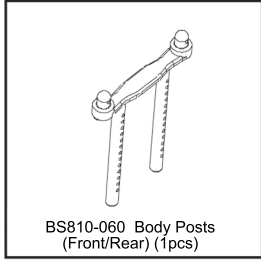

BS810-060 Body Posts
(Front/Rear) (1pcs)

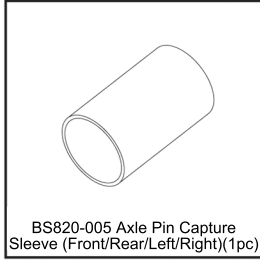

BS820-005 Axle Pin Capture
Sleeve (Front/Rear/Left/Right)(1pc)

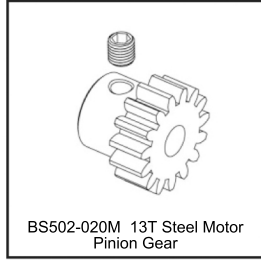

BS502-020M 13T Steel Motor
Pinion Gear

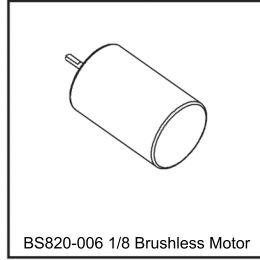

BS820-006 1/8 Brushless Motor

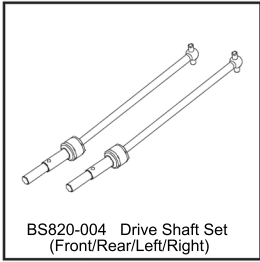

BS820-004 Drive Shaft Set
(Front/Rear/Left/Right)

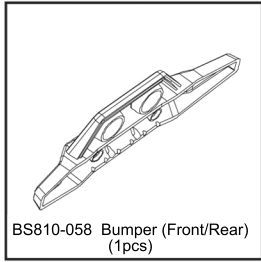

BS810-058 Bumper (Front/Rear)
(1pcs)

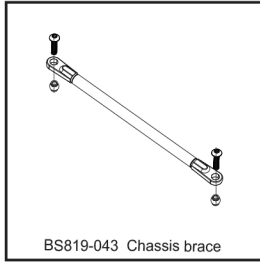

BS819-043 Chassis brace

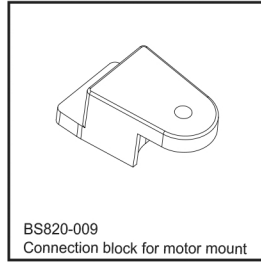

BS820-009
Connection block for motor mount

PERFORMANCE UPGRADES



HX-403 LIPO Balance Charger



HX-580030C-D LIPO Battery
7.4V, 5800mAh, 30C



www.REDCATRACING.com

Follow us on social media

Take a photo, create a video, post and share your Redcat experience

Stay up to date on the latest Redcat news, products, and creative content. While these profiles are not customer service channels, you might find that one of our subject experts or another member of the community is able to assist you. If you have an issue or need technical and or product support, please reach out to Redcat directly through our website.

 <https://www.facebook.com/RedcatRacing>

 <https://www.instagram.com/RedcatRacing>

 <https://www.youtube.com/RedcatRacing>

 <https://www.twitter.com/RedcatRacing>

 <https://www.pinterest.com/RedcatRacing>

IMPORTANT LINKS:

Link to the most recent version of this manual with exploded views and parts lists:
www.redcatracing.com/pages/manuals

Link to electric vehicles manual:
www.redcatracing.com/manuals/ELECTRIC-MANUAL.pdf