

CARBON

210 RACE DRONE



14+

MAN-CARBON210RACEDRONE-2017.3.20
To ensure you are using the most recent version of this manual:
www.redcatracing.com/manuals/CARBON210MANUAL.pdf

TABLE OF CONTENTS

0.0 Warnings -----	1
1.0 Needed Items -----	2
2.0 Overview -----	3
3.0 Remote Controller -----	4
4.0 Specifications -----	5
5.0 Before Flight -----	6
6.0 Charge the Battery -----	6
7.0 Prepare the Drone -----	6
7.1 Antenna Installation -----	6
7.2 Propeller Installation -----	7
7.3 Battery Installation -----	7
7.4 Camera Angle -----	7
8.0 Ready for Flight -----	8
8.1 Binding the Controller -----	8
8.2 Motor Unlock/Lock -----	9
9.0 Flight Controls -----	10-11
10.0 Calibration -----	12
11.0 Post Flight -----	12
12.0 Additional Information -----	13
12.1 OSD information -----	13
12.2 Video Transmitter Signals -----	13-15
12.3 Power Board Overview -----	16
12.4 Brushless ESC and Motor Connection Diagram -----	17
12.5 Radio Receiver Overview -----	17-18
12.6 CLEANFLIGHT Software -----	18
13.0 Charger Specifications -----	19
14.0 Trouble Shooting -----	20
15.0 Parts -----	21

O.O WARNINGS

The Redcat Racing Drone is not a toy and should not be used by children under the age of 14 years of age. Adult supervision is required.

Check your local and federal laws and regulations. Do not fly the drone on or near no-fly zones. Adhere to all local and federal laws regarding piloting Drones and other Unmanned Aircraft Systems.

You are required to register this drone online @ registermyuas.faa.gov

Please read and understand the entire user manual and make absolutely sure you have mastered the various functions and operation of this drone before using in public areas.

Do not fly this drone in or over crowds or populated areas. Video signals being transmitted from drones may be lost or interrupted by unforeseen circumstances, causing injury or damage to the pilot or others.

This drone can cause serious injury or death if not operated correctly. Never use this drone in crowds. Never chase people or animals. Fly in safe open areas only. Keep body parts away from moving parts.

Redcat Racing will not take any responsibilities of damage, injury, or financial loss by user operation.

There is a risk of fire and explosion when dealing with batteries. Rechargeable batteries may become hot and catch fire if left unattended or charged too quickly. Use extra caution when charging LiPO batteries. Use only LiPO specific chargers. Use a LiPO safe charging pouch when charging LiPOs. Charge away from flammable materials. Never charge at a rate higher than 1C. {2000Mah pack= 2amps charge rate). Overcharging can lead to fire and explosion. Always store battery packs in a cool dry place.

Use caution when charging batteries. Do not touch positive and negative leads together. Do not lay battery on metal. Use only chargers specified for the battery type being charged. Keep batteries and chargers away from water.

FCC Compliance Statement! The radio included with your vehicle complies with part 15 of the FCC Rules. Operation is subject to the following two conditions: (1) This device may not cause harmful interference, and (2) This device must accept any interference received, including interference that may cause undesired operations. Note: This equipment has been tested and found to comply with the limits for a Class B digital device, pursuant to Part 15 of the FCC Rules. These limits are designed to provide reasonable protection against harmful interference in a residential installation. This equipment generates, uses and can radiate radio frequency energy and, if not installed and used in accordance with the instructions, may cause harmful interference to radio communications. However, there is no guarantee that interference will not occur in a particular installation. If this equipment does cause harmful interference to radio or television reception, which can be determined by turning the equipment off and on, the user is encouraged to try to correct the interference by one of the following measures:

Reorient or relocate the receiving antenna.

Increase the separation between the equipment and receiver.

Connect the equipment into an outlet on a circuit different from that to which the receiver is connected.

Consult the dealer or an experienced radio/TV technician for help.

WARNING: Any changes or modifications not expressly approved by the party responsible for compliance could void the user's authority to operate this equipment.

WARNING: While operating the Radio, a separation distance of at least 20 centimeters must be maintained between the radiating antenna and the body of the user or nearby persons in order to meet the FCC RF exposure guidelines.





MADE IN CHINA

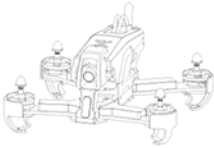

SPECIFICATIONS,
COLORS AND CONTENT
MAY VARY FROM ILLUSTRATIONS

I.O **NEEDED ITEMS**

Be sure to have all items on the list before using the drone.

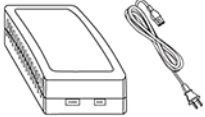
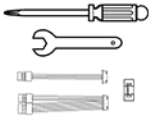
Item	Name
	Carbon 210 Race Drone
	Remote Controller
	Rotor Blades (4 x 5045 / 4 x 5045R)
	11.1V Rechargeable LIPO Battery Pack 1500mAh - 25C - 3S
	LIPO Charger
	Screwdriver Wrench S-BUS Cable PWM Cable Video Receiver Connector

2.0 OVERVIEW

- The Carbon 210 drone chassis is constructed of Carbon-Fiber Reinforced Plastic (CFRP) for added rigidity and crash survivability.
- The modern industrial modular design, allows easy part replacement, upgrades, and maintenance.
- Advanced 5.8Ghz live video feed for use with an OSD (On Screen Display) system allows for the FPV experience with the use of goggles or remote display (sold separately).
- The Carbon 210 Drone employs a modern flight control system for aerobatic flight routines such as rolls, flips and race course maneuvers.

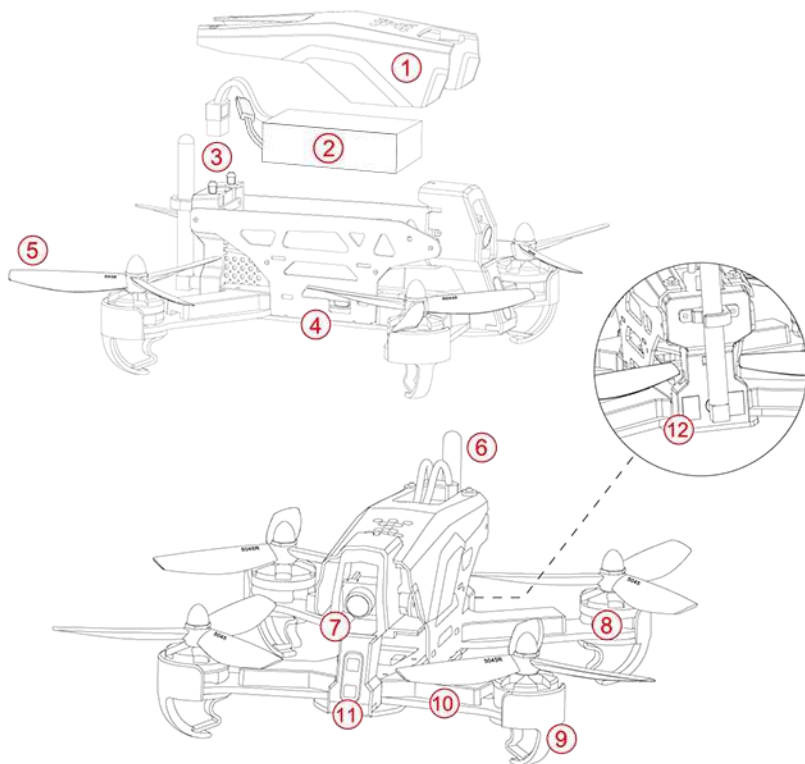

- | | |
|--------------------|-------------------------------|
| 1. Upper shell | 7. Camera |
| 2. LIPO battery | 8. Brushless motor |
| 3. Power Connector | 9. Landing skid / motor guard |
| 4. USB port | 10. Brushless ESC |
| 5. Propellers | 11. LED headlight |
| 6. Antenna | 12. LED taillight |

3.0 REMOTE CONTROLLER

The Carbon 210 Drone features 3 flight modes: BEGINNER, ADVANCED, and PROFESSIONAL

Select the appropriate mode according to your piloting skills.

NOTE: Always start each flight in BEGINNER mode, until you are comfortable with the aircraft.

- **BEGINNER Flight Mode:** The Drone uses flight stabilization and its controls are limited. In this mode, the drone can not performs rolls. This mode is suitable for beginner pilots.
- **ADVANCED Flight Mode:** The Drone uses partial flight stabilization and its controls are semi-limited. In this mode, the drone can performs rolls. This mode is suitable for intermediate pilots.
- **PROFESSIONAL Flight Mode:** The Drone does not use any flight stabilization and its controls are completely unlocked. In this mode, the drone can performs rolls and other stunts. This mode is suitable for advanced pilots only. The drone will be very responsive for high speed and aerobatic flight.

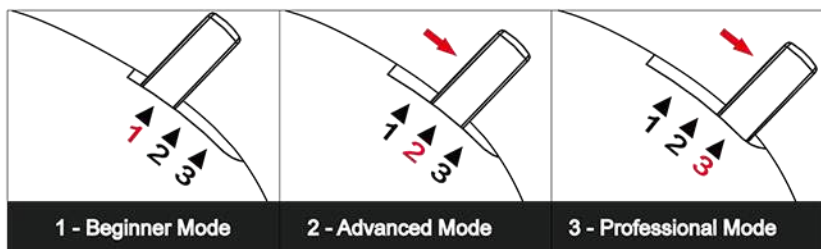

1. Flight Mode Switch:
 - BEGINNER
 - ADVANCED
 - PROFESSIONAL
2. Right Stick
3. Neck Strap Mounting Loop
4. Left Stick
5. Disarm/Arm Button
6. Power Indicator
7. Speaker
8. Power Switch
9. Handle
10. Battery Compartment

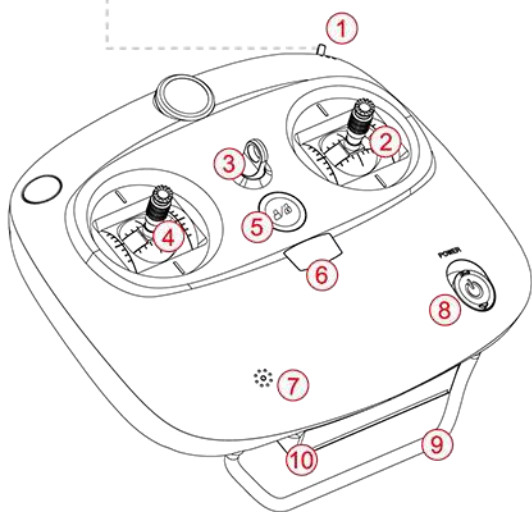

4.0 SPECIFICATIONS

Drone

Model No.:	S2-210
Product name:	Carbon 210 Race Drone
Flying Weight:	1.0472 lbs. (with battery)
Dimensions:	7.36in. x 7.2in. x 3.66in.
Wheel Base:	8.27in.
Rotors:	5045(R) x2(x2) (5 in, 3 blades)
Flight Time:	8-10 minutes
Max. Tiltable Angle:	360°
Brushless ESC:	30A
Battery:	11.1V 1500mAh 25C 3S LIPO
Brushless Motor:	2204 KV2500 (CW/CCW)
On Screen Display:	Carbon 210 Race Drone OSD
Receiver:	6CH, supports - S-BUS / PWM / PPM
Receiver Sensitivity:	-95 dBm
Flight Control:	SPRacing F3
Video Transmission:	5.8GHz real-time video transmission / audio (40 race channels)
Working Temperature:	14°F - 122°F
Video Transmitter Output Power:	25MW - 200MW

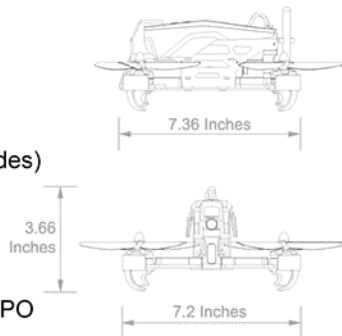

Remote Controller

Channels:	6CH
Working Frequency:	2.4GHz
Power:	<20dBm
Working Current:	80mA
Battery:	4PCS - 1.5V AA batteries
Remote Distance:	600m (outdoor, open space)

Camera

Horizontal Resolution:	600TVL
System Format:	PAL / NTSC
Lens Angle:	Horiz:120° Vert:100°
Optical Spec:	1/4" (CMOS)

5.0 BEFORE FLIGHT

- This drone is recommended for pilots, 14 years or older, with RC hobby experience.
- Only fly this drone in dry weather, with low wind, and do not fly in rain or heavy fog.
- Always choose large open spaces for flight. Check local laws and ordinances for legal flying areas and possible restrictions.
- Always keep at least 10 feet of distance between the aircraft and anyone else when armed, to avoid injury from the high-speed propellers during flight or on the ground.
- Always disarm the rotors before handling the aircraft.
- Do not fly close to high-voltage power lines, cellphone towers, or radio towers, as these may disrupt your control signal.
- Always check local laws before flying. Never fly in public areas filled with people. Redcat Racing will not take any responsibilities of damage, injury, or financial loss by user operation.

6.0 CHARGING THE BATTERY

1. Plug the charger into to a regular 110v wall outlet.
2. Plug the LIPO battery balance connector into the charger.
3. While charging, the LED lights will be solid red. When charging is complete, the LED lights will be solid green. Charge time is ~ 50-70 minutes.

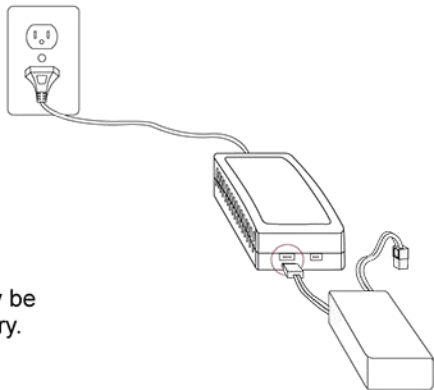

Attention:

When the RED LED lights flash, there may be something wrong with the charger or battery. Stop charging immediately!

7.0 PREPARE THE DRONE

Be sure to perform steps 7.1 - 7.4 before flight.

7.1 ANTENNA INSTALLATION

1. Install the antenna by screwing it into the rear of the drone between the taillight LEDs.
2. Secure the top of the antenna by snapping it into the antenna clip as shown in the diagram.

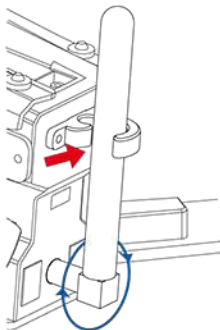

7.2 PROPELLER INSTALLATION

Install the two Clockwise Propellers (5045R) onto the two Clockwise Motors. (CW) (blue arrows)

Install the two Counter-clockwise Propellers (5045) onto the two Counter-clockwise Motors. (CCW) (red arrows)

Using a small wrench, tighten all propellers. Double check all propellers are installed correctly. The drone will not be controllable if they are not installed according to the diagram to the right.

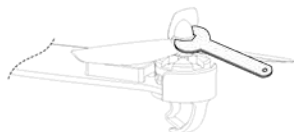
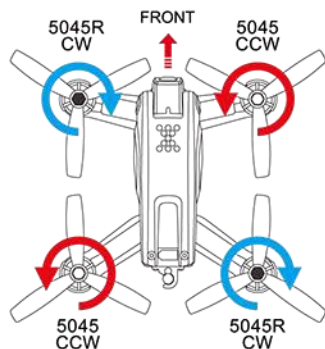

Attention:

Install each rotor by hand and tighten with the included wrench.

7.3 BATTERY INSTALLATION

1. First put the aircraft on a flat surface.
2. Remove the upper shell and put the battery into the battery compartment. Secure the battery with the Velcro strap.
3. Re-install the upper shell.

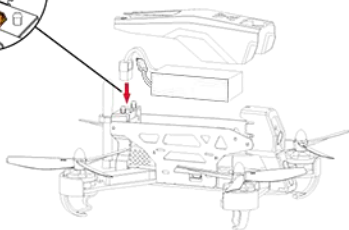
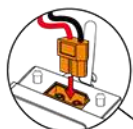

Attention:

Always remove the upper shell from the rear of the drone first, then slowly remove the front of the shell. Never plug in the battery until you are ready to fly.

7.4 CAMERA ANGLE

1. Use a screwdriver to loosen the screws on both sides of the camera mount.
2. Adjust the angle of the camera up or down. A good starting angle is pointing straight ahead and slightly angled down.
3. Re-tighten the screws on both sides of the camera mount.

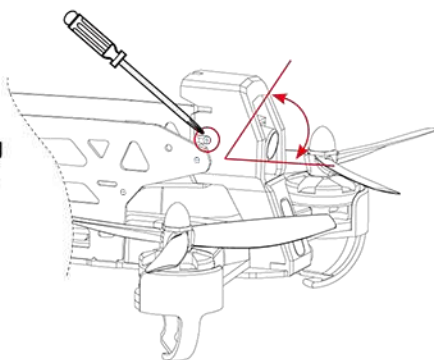

8.0 READY FOR FLIGHT

Attention:

1. Place the aircraft down on a flat level surface in a wide open space. Positioned with the rear of the drone facing you.
2. Put the flight mode switch to the position (1). Move the throttle stick to the lowest position, then turn on the remote controller.
3. Video receiving equipment is needed (goggles, glasses, etc.) to display a FPV (First Person View) image and OSD (On Screen Display) information.
4. The drone has a low-voltage alarm function. The OSD gives you a visual reference for the remaining battery power. When battery voltage drops below 10.5 volts, the light will flash quickly and the aircraft will sound an alarm.

This aircraft is designed for FPV racing, there is no "automatic landing mode".

WARNING:

Do not hesitate to land when you hear the battery alarm or see the OSD flashing, indicating the battery is below 10.5 volts. Once the alarm sounds, the drone will no longer be able to be flown at full throttle and it will begin to descend. Use the controls to navigate the drone down for a safe landing.

8.1 BINDING THE DRONE AND CONTROLLER

The controller must be bound to the drone before the first flight.

1. Turn on the controller (make sure the throttle stick at the lowest position)

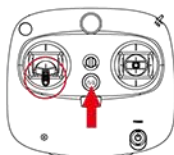

2. Set the drone on a flat surface and plug the battery into the drone. The front and rear LEDs will turn on.

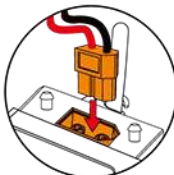

3. When the RIGHT red LED flashes slowly and finally turns off, binding is complete. The drone is now bound to the controller.

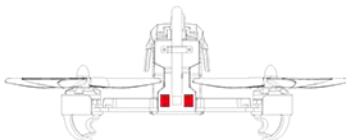

Left LED Light

Right LED Light

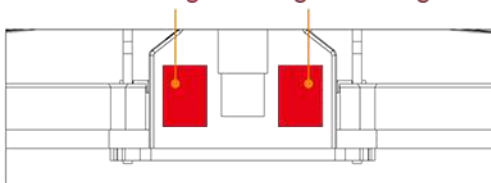

8.2 UNLOCKING/LOCKING MOTORS

1. Place the drone on a flat level surface, in a wide open area.
2. Pull the throttle stick to the lowest position and be sure the mode lever is set to the beginner position.
3. Turn on the controller, then press the motor lock/unlock button. The motors will start automatically at low speed.

Unlock Motors

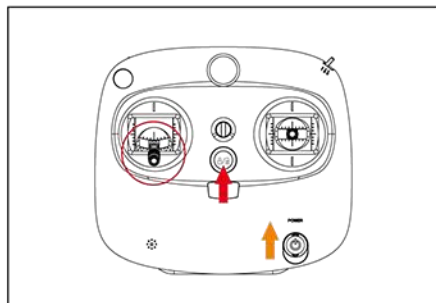

Keep the throttle stick at the lowest position

Turn on the controller,
Press the lock/unlock button to unlock the motors

The motors start spinning at low speed

BOTH red LEDs will turn on

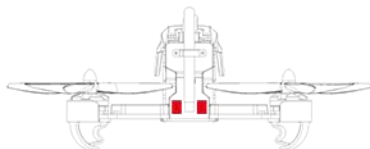

Lock Motors

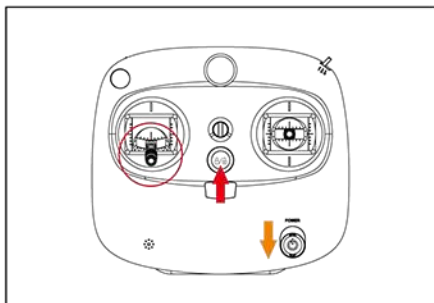

Keep the throttle stick at the lowest position

Press the lock/unlock button to lock the motors,
Turn off the controller

The motors stop spinning

The RIGHT red LED will turn off

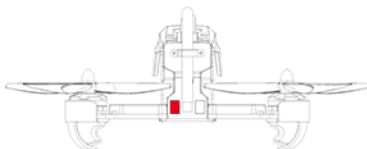

9.0 FLIGHT CONTROLS

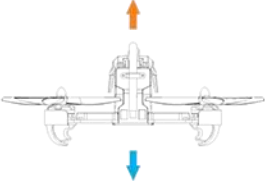
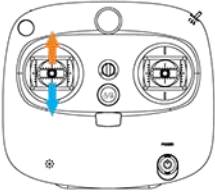
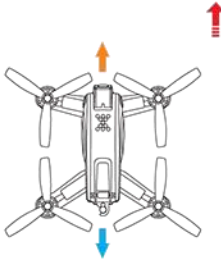
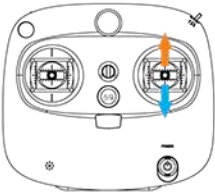
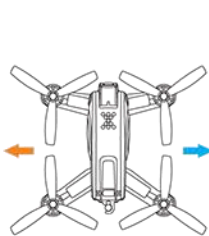
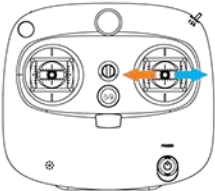
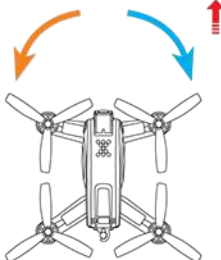
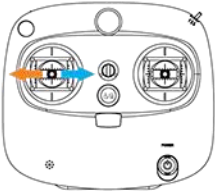
Aircraft Orientation () Indicates front of drone	Controller Controls
<p>THROTTLE Up / Down</p> <p>Drone should face away from pilot</p> 	<p>(Throttle stick on left)</p> 
<p>PITCH Forward / Backward</p> 	
<p>ROLL (Strafe) Left / Right</p> 	
<p>YAW (Turning) Left / Right</p> 	

9.0 FLIGHT CONTROLS CONT. FLIPS/ROLLS

Drone Flips Forward

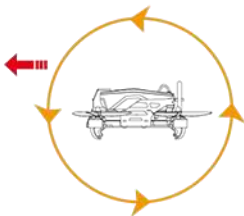

Drone Flips Backward

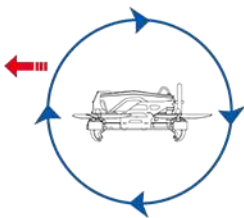

Drone Rolls Right

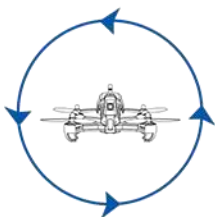

Drone Rolls Left

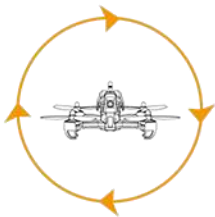

FLIPS

Flips are only available in Advanced and Professional modes. Set the Mode Switch to modes 2 or 3 to begin doing flips.

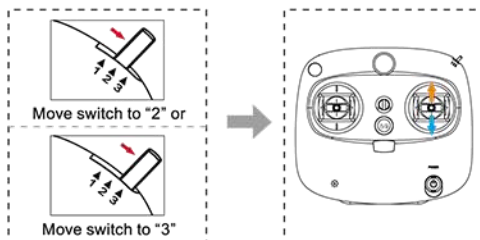

Attention:

1. Always select large open areas to fly.
2. Flips are best suited for experienced pilots.
3. Adjust the throttle to maintain altitude.

ROLLS

Rolls are only available in Advanced and Professional modes. Set the Mode Switch to modes 2 or 3 to begin doing flips.

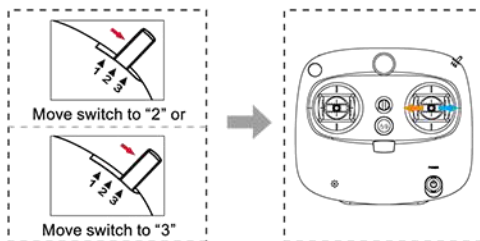

Attention:

1. Always select large open areas to fly.
2. Rolls are best suited for experienced pilots.
3. Adjust the throttle to maintain altitude.

10.0 CALIBRATION

If the drone drifts while hovering or is unstable in Beginner flight mode, the internal gyroscope needs to be calibrated. Follow these steps for calibration.

1. Put the drone on a flat level surface and power on.
2. Turn on the controller and make sure the Motor Lock/Unlock button on the controller is set to Lock.
3. Push both left and right sticks to the top center position at the same time and hold them there. (See diagram below) The drone will sound "B ... BBB". When the beeping stops, calibration is complete.

WARNING:

Be sure the motors are locked on the controller and the drone is on a flat surface before calibrating the gyros.

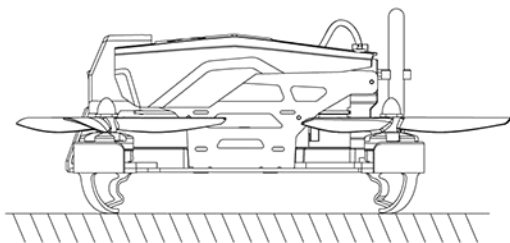
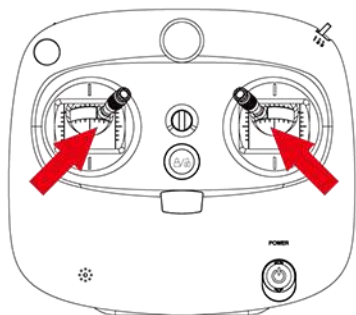

11.0 POST FLIGHT

1. Land the drone and lock the motors.
2. Power off the drone by unplugging the battery, then turn off the controller.
3. Remove the battery from the drone and store it in a cool dry area suitable for battery storage.

WARNING:

Be sure to follow these steps every time you are done flying the drone. Failure to do so may lead to injury or damage to drone, battery, or property.

12.0 ADDITIONAL INFORMATION

12.1 OSD INFORMATION

The OSD (On Screen Display) information is visible on your FPV Goggles or FPV Screen with video receiver. FPV Goggles and FPV Screen not included.

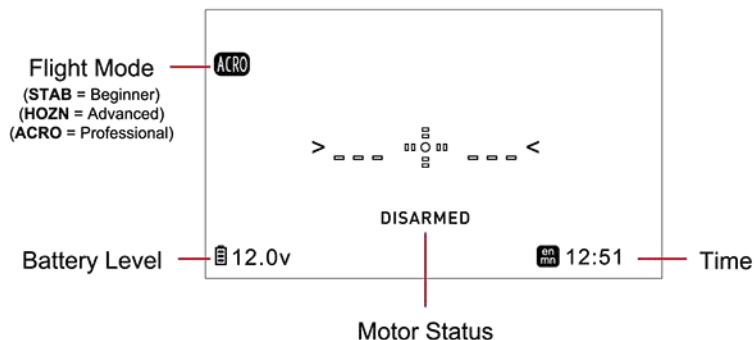

12.2 VIDEO TRANSMITTER SIGNALS

There are 40 possible channel selections. Select the best channel according to the signal on the screen of your video receiving equipment.

Adjust the dip-switches to select the clearest channel available. Examples shown below.

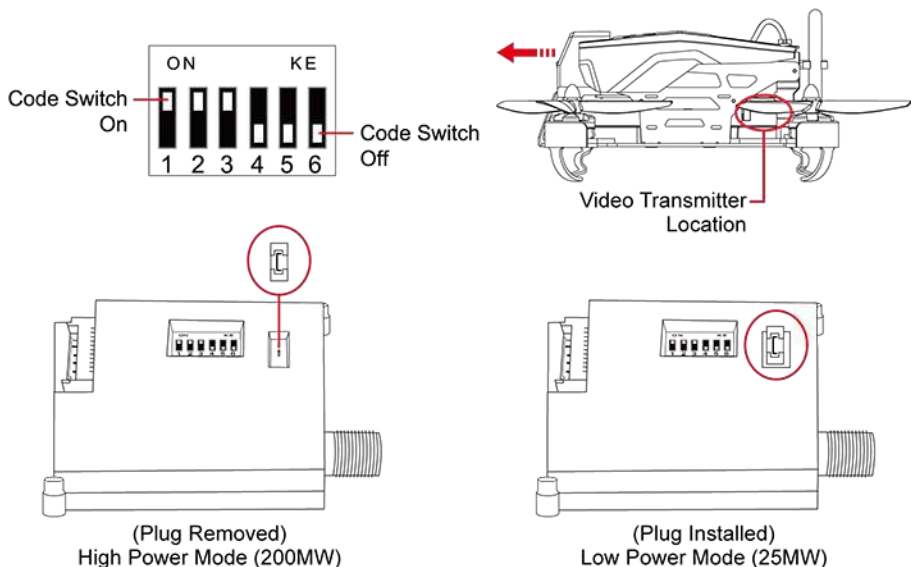

12.2 VIDEO TRANSMITTER SIGNALS CONTINUED

When the plug is installed, Low Power Mode is active (25MW). In Low Power Mode, multiple drones can transmit video signals simultaneously, with minimal interference. The low power signal may not travel through objects and obstacles, so a clear line of sight is needed.

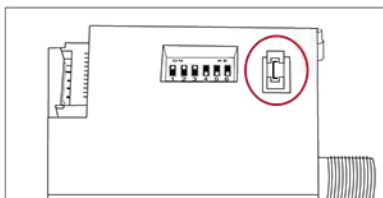

25MW Low Power Mode (plug installed)

Channel	1	2	3	4	5	6	7	8
Frequency Point	5740	5760	5780	5800	5820	5840	5860	5860
Dip-switch Position								

Channel	9	10	11	12	13	14	15	16
Frequency Point	5745	5745	5765	5785	5805	5825	5845	5865
Dip-switch Position								

Channel	17	18	19	20	21	22	23	24
Frequency Point	5733	5752	5771	5790	5809	5828	5847	5866
Dip-switch Position								

Channel	25	26	27	28	29	30	31	32
Frequency Point	5733	5752	5771	5790	5809	5828	5847	5866
Dip-switch Position								

Channel	33	34	35	36	37	38	39	40
Frequency Point	5732	5732	5732	5769	5806	5843	5843	5843
Dip-switch Position								

12.2 VIDEO TRANSMITTER SIGNALS CONTINUED

With the plug removed, High Power Mode is active (200MW). High Power Mode can be used in many situations, except races involving multiple drones. When many drones are transmitting high powered video signals at once, interference will occur.

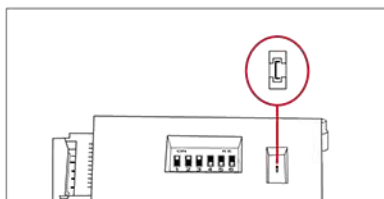

200MW High Power Mode (plug removed)

Channel	1	2	3	4	5	6	7	8
Frequency Point	5740	5760	5780	5800	5820	5840	5860	5880
Dip-switch Position								

Channel	9	10	11	12	13	14	15	16
Frequency Point	5725	5745	5765	5785	5805	5825	5845	5865
Dip-switch Position								

Channel	17	18	19	20	21	22	23	24
Frequency Point	5733	5752	5771	5790	5809	5828	5847	5866
Dip-switch Position								

Channel	25	26	27	28	29	30	31	32
Frequency Point	5705	5685	5665	5645	5885	5905	5925	5945
Dip-switch Position								

Channel	33	34	35	36	37	38	39	40
Frequency Point	5658	5695	5732	5769	5806	5843	5880	5917
Dip-switch Position								

12.3 POWER BOARD OVERVIEW

The diagram below shows where component connections are located on the power board. Do not alter the power board circuitry. If the power board is damaged, only certified professionals should make repairs. Severe damage to the power board, drone, and persons may occur if repairs are done incorrectly.

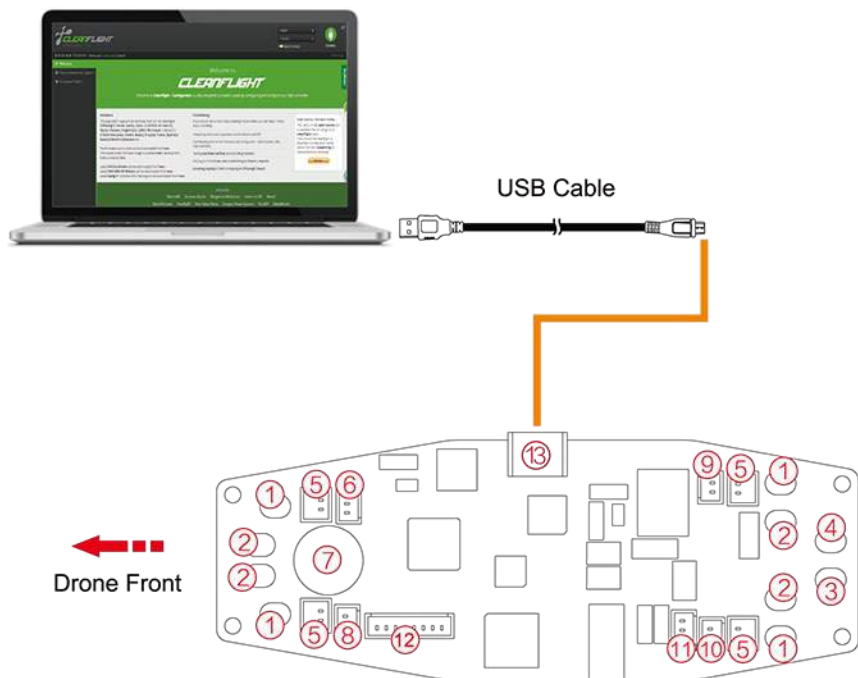
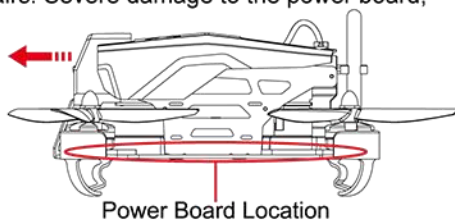

- | | |
|---|---------------------------------------|
| 1. ESC power connection port (negative) | 8. Headlight connection port |
| 2. ESC power connection port (positive) | 9. Right LED light connection port |
| 3. Power connection port (negative) | 10. Left LED light connection port |
| 4. Power connection port (positive) | 11. Video transmitter connection port |
| 5. ESC signal connection port | 12. Receiver connection port |
| 6. Camera connection port | 13. USB port |
| 7. Alarm* ⚠ WARNING: The alarm will automatically sound when the signal between the drone and remote controller is lost or the battery voltage is below 10.5volts. | |

12.4 BRUSHLESS ESC AND MOTOR CONNECTIONS

⚠ WARNING: Hardware changes should only be done by a professional or someone with extensive experience with drones.

The diagram below shows motor and ESC connections. Soldering on new motors must be done by professionals or damage may occur. The professional may look at the diagrams below to see motor orientation. Note the orientation of the ESC for the clockwise (CW) motors compared to the counter clockwise (CCW) motors. The ESC is flipped over on the CW motors.

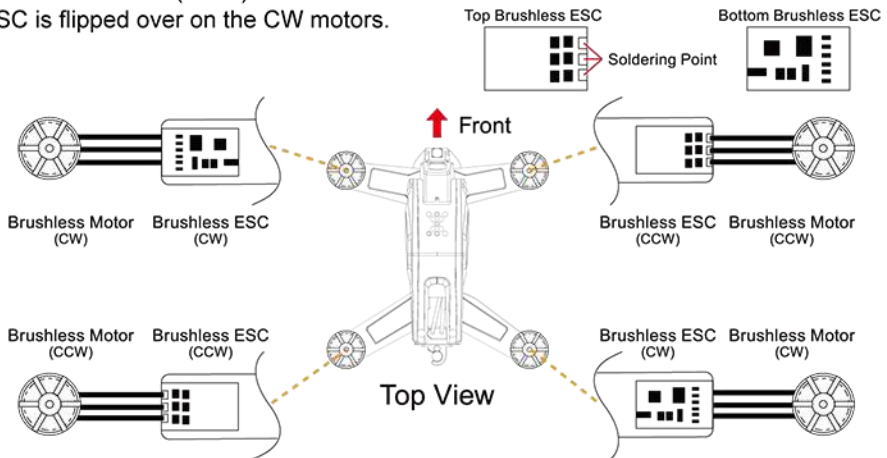

12.5 RADIO RECEIVER OVERVIEW

The diagram below shows the receiver connections. No changes are need as the receiver is ready to use and is preinstalled into the drone. Alterations or repairs must be done by a professional or damage may occur. The professional may use these diagrams for connecting new hardware.

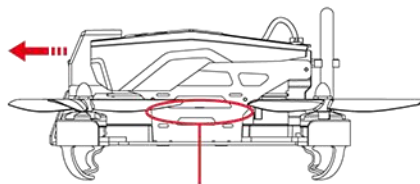

Transmitter Receiver Location

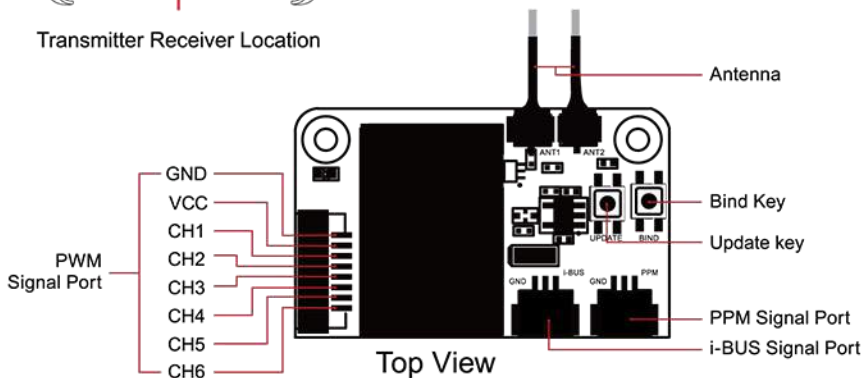

12.5 RADIO RECEIVER OVERVIEW CONTINUED

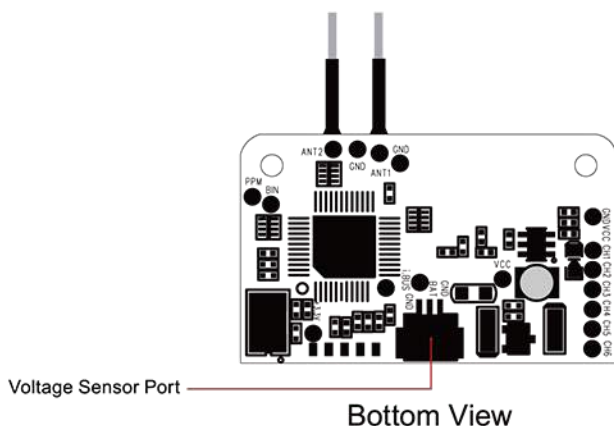

12.6 CLEANFLIGHT SOFTWARE

⚠ WARNING: For your safety, remove the propellers and lock the motors before connecting the drone to the computer with the USB cable.

This drone works with CLEANFLIGHT software, but should only be used by extremely advanced pilots. The drone is already set to run smoothly and only highly advanced users should make changes to the drone in CLEANFLIGHT.

To download CLEANFLIGHT, go to www.cleanflight.com and click the GUI download link and follow the install instructions.

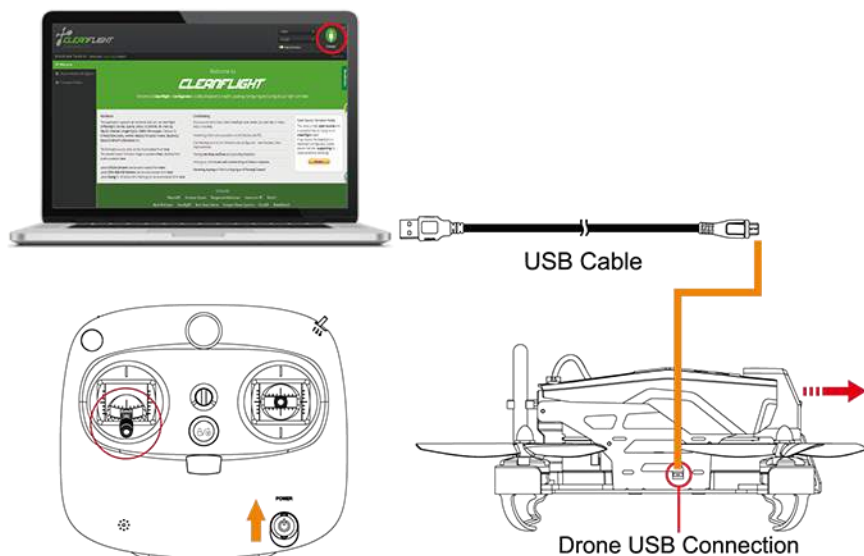

13.0 CHARGER SPECIFICATIONS

Input Voltage: 100V 50/60HZ
Output Current: 0.8A
Output Power: 10W
Dimensions: 3.55 x 2.25 x 1.3 in.



- The charger utilizes circuitry to consistently balance charge LIPO and Li-ion battery packs. LED indicators are used to show real-time charging status.
- The charger can be used to charge 3S (11.1V) Li-ion and LIPO battery packs.

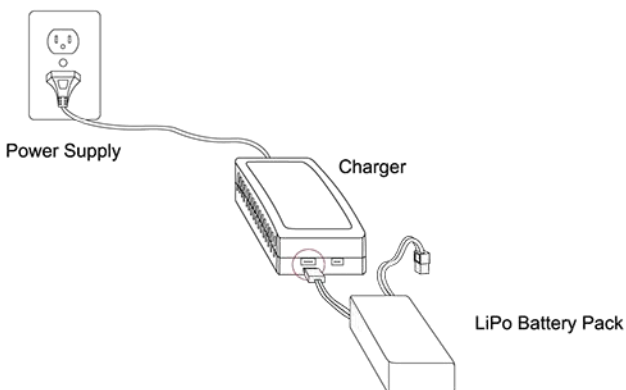

































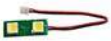

⚠ WARNINGS:

- The charger can ONLY be used for charging 3S LIPO and Li-ion batteries.
- During charging, the charger should be placed in a dry, well ventilated place, far from heat sources and flammable or explosive substances.
- Always remove the battery from the drone before charging.
- Never charge unsupervised or over night, stay close and monitor the charger for the entire charge duration.
- Always let the battery cool at least 10 minutes after flying the drone before attempting to charge. An overheated battery may swell or catch fire while charging.
- Before connecting the battery, make sure polarity is correct and never force a connector.
- Avoid dropping a charging or charged battery.
- DO NOT charge a damaged battery. If the battery shows any signs of damage like cuts, swelling, bends, or dents, do not charge the battery.
- Dispose of damaged batteries by submerging in a pot of salt-water for 30 minutes, then bring the battery to a battery recycling center.

14.0 TROUBLESHOOTING

PROBLEM	CAUSE	SOLUTION
The controller beeps and red light keeps flashing.	Controller is not ready to be bound to the drone.	Ready the controller by pushing the throttle control (left stick) all the way down. (See 8.1 Binding the Controller)
Drone is unresponsive.	Controller and or drone is not powered ON.	Turn both controller and drone ON.
	Controller batteries are installed incorrectly.	Install the batteries with the correct polarity.
	Controller batteries are drained.	Install fresh batteries to the controller.
Controller light is ON. Drone is unresponsive.	Drone's battery pack is drained.	Charge the drone's battery pack.
Drone's rotors spin but doesn't take off.	Rotor blades are damaged.	Replace the damaged rotor blades.
	Drone's battery pack is drained.	Charge the drone's battery pack.
	Drone is not on a flat surface.	Place the drone on a flat surface before attempting to take off.
	Rotor blades are installed incorrectly.	Check rotors and make sure they are installed face up and on correct motors.
Drone is shaking while flying.	Rotor blades are damaged.	Replace the damaged rotor blades.
Drone moves while hovering without controller input.	Drone was not started on a flat surface.	Recalibrate the drone. (See 10.0 Calibration)
Video feed is fuzzy, cuts out, or is distorted.	There is channel interference.	Change the video feed channel selector on the drone to a better looking channel.
	A poor connection.	Keep line of sight. Move to a clearer area free from buildings and people.
No video feed displayed on device.	Display settings are not correct.	Check display channel settings and compatibility with drone frequency points.
	Drone is set to the wrong channel.	Change channel to a compatible channel for the receiving device.
Drone descends while flying.	Drone's battery pack is drained.	Wait 10 minutes, then charge the battery pack normally.
Drone does not connect to Cleanflight software.	Drone is off.	Connect the battery pack to turn on.
	Micro USB is not fully connected.	Unsure USB is fully plugged in at both connection points.

I 5.0 PARTS

<p>S2-210-1: 5045 Propellers (4pcs) (CW/CCW)</p> 	<p>S2-210-2: LIPO Battery (11.1V, 1500mAh, 25C, 3S)</p> 	<p>S2-210-3: Upper Shell w/ 2x Rubber Grommets</p> 	<p>S2-210-4: Camera Mount PB2*6mm (3pcs), PWA2*6mm (2pcs)</p> 	<p>S2-210-5: PCB Board PB2*8mm (8pcs)</p> 
<p>S2-210-6: Lower Board w/ PB3*10mm (8pcs)</p> 	<p>S2-210-7: Battery Tray KM2*6mm (2pcs)</p> 	<p>S2-210-8: Left Side Panel PB2*8mm (2pcs) PB2*6mm (2pcs)</p> 	<p>S2-210-9: Right Side Panel PB2*8mm (2pcs) PB2*6mm (2pcs)</p> 	<p>S2-210-10: Front Arms M3*8mm (8pcs)</p> 
<p>S2-210-11: Rear Arms M3*8mm (8pcs)</p> 	<p>S2-210-12: Video Transmitter 5.8GHz 25mW-200mW</p> 	<p>S2-210-13: Transmitter Box PB1.2*4mm (2pcs)</p> 	<p>S2-210-14: HD Mini Camera (600TVL)</p> 	<p>S2-210-15: Brushless Motor (CW) (1pc)</p> 
<p>S2-210-16: Brushless Motor (CCW) (1pc)</p> 	<p>S2-210-17: Landing Skids (4pcs)</p> 	<p>S2-210-18: Power Board PB2*6mm (4pcs)</p> 	<p>S2-210-19: Brushless ESC</p> 	<p>S2-210-20: ESC Cover (4pcs) PB2*8mm (8pcs)</p> 
<p>S2-210-21: Front Crash Plate PM2.5*4mm (3pcs)</p> 	<p>S2-210-22: Headlight Lens Cover</p> 	<p>S2-210-23: Antenna Mount PB2*6mm (2pcs) PB2.5*6mm (2pcs)</p> 	<p>S2-210-24: Antenna 5.8GHz Video Transmitter</p> 	<p>S2-210-25: Battery Strap</p> 
<p>S2-210-26: Controller / Receiver 2.4GHz / KM2*6mm (2pcs)</p> 	<p>S2-210-27: Headlight</p> 	<p>S2-210-28: Taillight</p> 	<p>S2-210-29: Fixed Circular PB2*6mm (2pcs)</p> 	<p>S2-210-30: Taillight Lens Cover</p> 
<p>S2-210-31: Battery Anti-Slip Mat</p> 	<p>S2-210-32: Screw Set</p> 	<p>HX-A3: LIPO Charger</p> 	<p>S2-210-34: Carrying Case</p> 	



FAST AFFORDABLE FUN™

www.redcatracing.com



Follow us on FaceBook: <https://www.facebook.com/RedcatRacing>

MAN-CARBON210RACEDRONE-2017.3.20

To ensure you are using the most recent version of this manual:
www.redcatracing.com/manuals/CARBON210MANUAL.pdf