

REDCAT-RACING

*1/8 BRUSHLESS DESERT TRUCK
MODEL :AFTERSHOCK 8E THREE DIFF*



*Product Size:
Length:504mm
Width:305mm
Height:165mm
Wheelbase:325mm
Tires size:117*44mm
Ground clearance:33mm
Motor:RC 540 KV:2230
ESC:EZRUN-80A*

Instruction Manual

Highlights:

- 4 Wheel Drive System
- Ready Assemble Ready to Run
- High Performance RC 540 KV: 2230 Type Brushless Motor, More Power!
- Brushless ESC EZRUN-80A
- 3200 Mah 2x7.4V 20C Li-Po battery
- Assembled Chassis(3mm 6061 T6 Aluminum)
- Full Function Control
- Colored Coil Spring Damped Suspension System
- Waterproof and Dustproof Sealed Gearbox
- Fast and Easy Assembly and Disassembly of Receiver and Battery Cover
- Quality Differential with Four Bevel Gears
- Precise Sealed Ball Bearing for the Whole Model
- Aluminum Alloy Drive shafts
- The fastest and best brushless EP buggy in China!

⚠ SAFETY PRECAUTIONS

- This radio controlled racing car is not a toy!
- This high-performance R/C model is recommended for ages 14 and older.
- First-time builders should seek the advice of experienced modellers before commencing assembly.
- Take enough safety precautions prior to operating this model.
You are responsible for this model's assembly and safe operation!

www.redcatracing.com

Required equipment for operation

1. Tools required for building and maintenance:

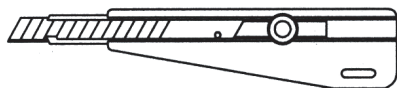

● Hobby knife

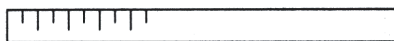

● Precision ruler

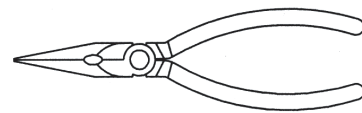

● Needle nose pliers

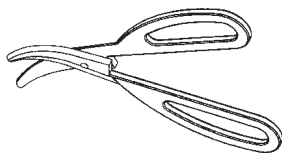

● Lexan scissors

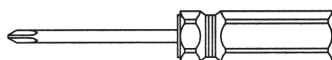
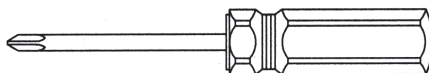

● Flat and Philips screwdriver

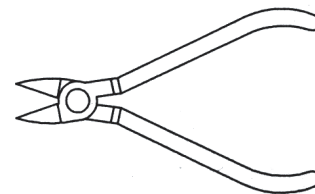

● Wire cutters

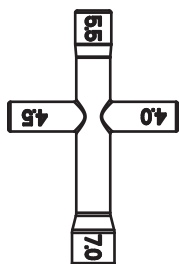

● Cross wrench

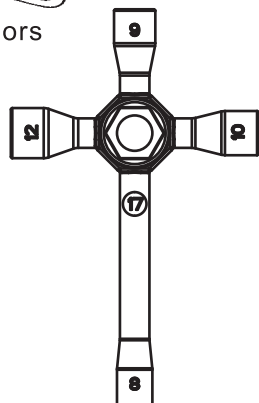

● Cross wrench



● CA glue&rubber cement



● Thread locking compound



● Hex wrench

WARNING!

Do not use a power screw driver to install screws into nylon or plastic materials. The fast locking may heat up the screws being installed that may break the molded parts or strip the threads during installation.

2. Additional items needed for operation:

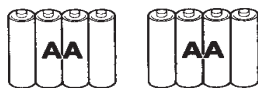

8pcs AA alkaline batteries for transmitter

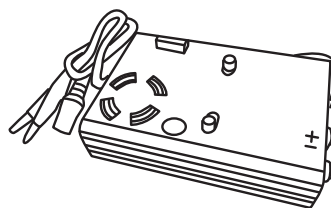

B7004-F

7.2V Ni-Mh battery & 2-4 cells
7.4V Li-Po battery charger

IMPORTANT!!!

Check all the screws are tight before playing the car!
Use thread lock on all screws that work loose.

Transmitter Specifications :

Channels: 2 channels
 Model Type: Car/boat
 RF Power: Less than 20dbm
 Modulation: GFSK
 Code Type: Digital
 Sensitivity: 1024
 Low Voltage Warning: Yes (less than 9V)
 DSC Port: Yes (3.5mm)
 Charger Port: Yes
 Power: 12vdc (1.5AA*8)
 Weight: 328g
 ANT Length: 26mm
 Size: 159*99*315mm
 Color: Black
 Certificate: CE FCC

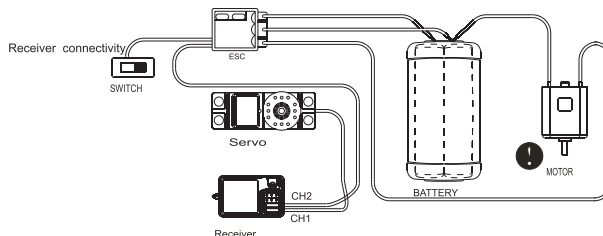
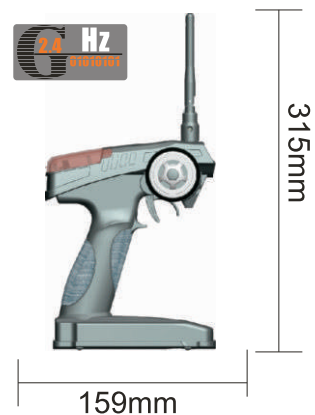

Note:

Place the antenna of the receiver vertically, and do not have contact with metal component. (See Figure1)

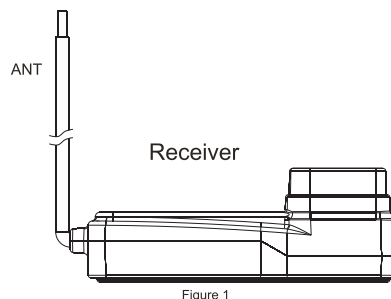

Binding:

The transmitter and receiver should already be bound by the factory by default .

1. Install batteries into the transmitter and shut it down.
2. Insert the bind cable on to the bind channel (Ch3) on the receiver. (Figure.2)
3. Connect the receiver battery to the VCC port on the receiver .The two LEDs on the receiver should flash rapidly, indicating the receiver is in binding state .
4. Press and hold the bind button on the transmitter , and then turn on the transmitter.
5. The LED on the receiver should stop flashing when the binding process completed (about 5 second)
6. Release the bind button on the transmitter , remove the bind cable from the receiver.
7. Install the servo and then test.
8. If the test succeeds , then remove the power supply from the VCC port.
9. The binding process completed.

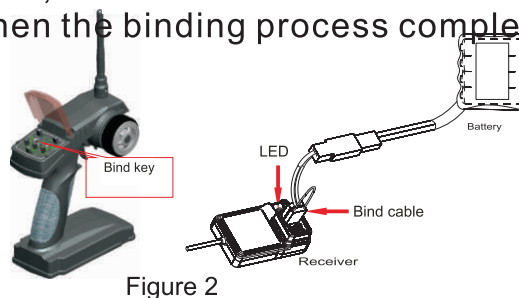

Turn On:

1. Turn on the transmitter.
2. Connect the power supply of the receiver.
3. Receiver LED light should turn solid.
4. Ready to use.

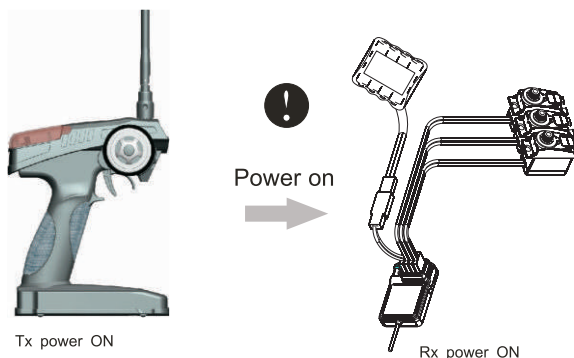

Shut Down:

1. Disconnect the receiver's power supply.
2. Turn off the transmitter .

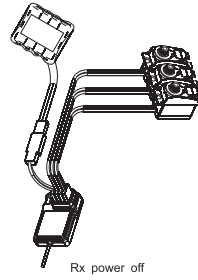

Shut down
→



Transmitter Functions:

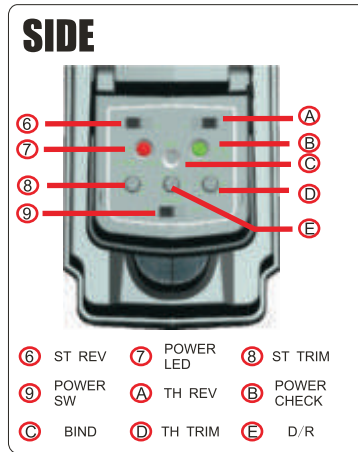
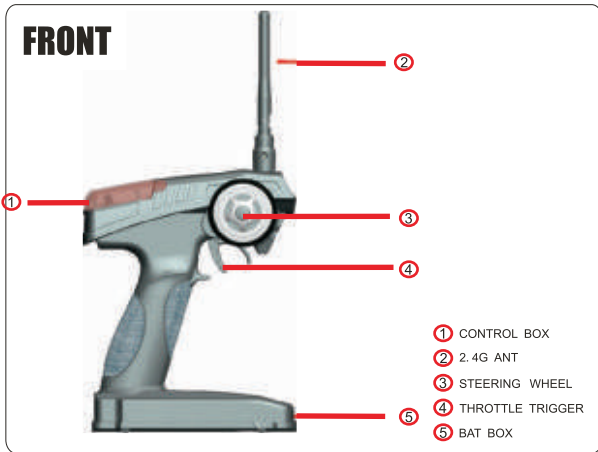

This function is to control the direction of the vehicle

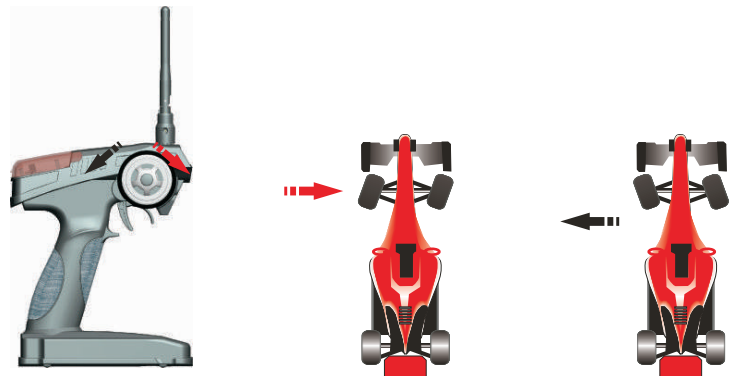

This function is to control the throttle speed of the vehicle

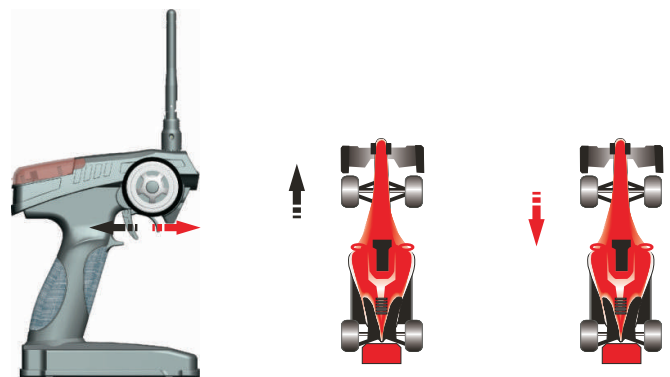

PARTS LIST

Item No.	Description	Item No.	Description
BS903-003	Shock absorber unit(plastic) 2pcs	BS903-087	Ball bearing (12*18*4) 2pcs
BS903-004	Shock absorber unit(alum.) 2pcs	BS903-089	Pin (2*9.5) 12pcs
BS903-005	Brace 1pcs	BS903-091	Washer A (5.2*10*0.2) 12pcs
BS903-007	Body pin 6pcs	BS903-092	Washer B (4.2*8*0.2) 12pcs
BS903-008	Upper susp. Arm set	BS903-094	Double way ball end 6pcs
BS903-010	Suspension arm mount block 2pcs	BS903-095	M4*4 set screw 6pcs
BS903-011	Upper susp.arm mount-Fr/Rr	BS903-097	Diff.gearbox
BS903-013	Axle w/pin	BS903-098	Diff.gearbox bulkhead-upper/lower
BS903-014	Ball bearing(6*12*4) 2pcs	BS903-106	Screw pin (M3*9.5) 12pcs
BS903-016	Ball bearing(10*15*4) 2pcs	BS903-107	Screw (M2.5*13) 12pcs
BS903-017	Fr/Rr C-carrier	BS903-109	Diff.outdrive A/Pin(2*10)
BS903-018	Fr.lower susp.arm-Lf/Rt	BS903-110	Diff.outdrive B/Pin(2*10)
BS903-019	Transverse driver shaft set	BS903-111	Kunckle Arm-L/R(metal)
BS903-023	O-washer 4pcs	BS933-006	Centre diff.box
BS903-024	Front suspension arm pin-short 4pcs	BS933-012	Spur gear(46T)
BS903-025	Suspension arm pin-long 4pcs	BS901-066	M3 locknut 5pcs
BS903-026	Fr.chassis	BS901-067	Antenna pipe w/cap
BS903-028	Lower susp.mount block-Fr/Rr	BS902-051	BT3*10 B-head cross screw 12pcs
BS903-030	Steering linkage set 2pcs	BS905-006	Tail wing 1pcs
BS903-058	Hub rear carrier	BS803-001	Chassis 1pcs
BS903-059	Rr.lower susp.arm-L /R	BS803-002	Side guard plate-L/R
BS903-061	Rear suspension arm pin-short	BS803-004	(ISO3*8) Flat cross screw 12pcs
BS903-065	TPF2.6*10 flat cross screw 12pcs	BS803-005	Steering servo mount-A/B
BS903-067	TPF3*10 flat cross screw 12pcs	BS803-006	Steering servo horn linkage 1 set
BS903-068	TPF3*14 flat cross screw 12pcs	BS803-007	Battery base-L
BS903-069	TPF3*16 flat cross screw 12pcs	BS803-008	Battery base-R
BS903-070	ISO3*10 flat cross screw 12pcs	BS803-009	Left/right battery cover
BS903-072	BT3*8 B-head cross screw 12pcs	BS803-010	Servo saver unit
BS903-073	BT3*12 B-head cross screw 12pcs	BS803-011	Upper deck-Fr
BS903-074	BT3*14 B-head cross screw 12pcs	BS803-012	Centre drive shaft-Fr 1pc
BS903-075	BT3*16 B-head cross screw 12pcs	BS803-013	Centre drive shaft-Rr 1pc
BS903-076	BT3*20 B-head cross screw 12pcs	BS803-014	(BM3*14) B-head cross screw 12pcs
BS903-079	BM3*10 B-head cross screw 12pcs	BS803-015	Receiver case-Upper/Lower
BS903-081	HM3*10 Cap head hexagon screw 6pcs	BS803-016	Front/rear upper deck mount
BS903-083	Diff.outdrive D/set screw	BS803-017	Upper deck-Fr/Rr
BS903-086	Ball bearing (5*10*4) 2pcs	BS803-018	Wire mount
		BS803-019	Centre diff.Unit

PARTS LIST

Item No.	Description	Item No.	Description
BS803-020	Centre diff mount	BS804-002	Silk-screened body 1pcs
BS803-021	Centre Diff Cover	BS904-003	Bumper 2pcs
BS803-022	Motor mount	BS904-004	Bumper brace 1pcs
BS803-023	Motor gear 15T/M3 Grub screw	BS904-005	Fr. bumper 1pcs
BS803-024	Brushless motor KV:2230	BS904-006	Rr. bumper 1pcs
BS803-025	Diff. gearbox unit	BS801-008	Fr/Rr body post
BS803-026	Diff. Uni	B7053	Transmitter complete
BS803-027	Driving/Driven Gear, Diff. Gear/Bevel gears	B7054W	Receiver
BS803-028	7.4V/20C LiPo battery	B7018W	Servo (9Kg)
BS804-001	Tire unit 2pcs	B7055W	Brushless ESC 80A

Optional parts/Upgrade parts

BS903-029	Anti-roll bar fixation set 2pcs
BS903-096	(M4*8) Set Screw 6pcs
BS905-009	Rear Anti-roll bar set
BS803-029	Motor heat sink
BS803-030	Motor cooling fan
B7004-F	7.2V Ni-Mh battery & 2-4 cells 7.4V Li-Po battery charger
MP0-02	C hub/c hub w/pin
MP0-04	Rear hub set
MP0-05	Shock stay mount
MP0-06	Front suspension mount
MP0-07	Rear suspension mount
MP0-11	Steering link



BS903-003 Shock absorber unit(plastic) 2pcs
BS903-004 Shock absorber unit(alum.) 2pcs

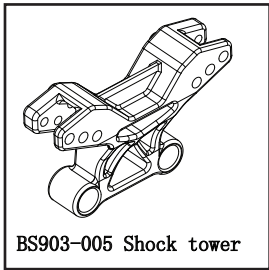

BS903-005 Shock tower

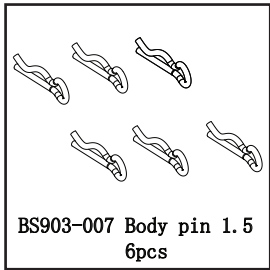

BS903-007 Body pin 1.5 6pcs

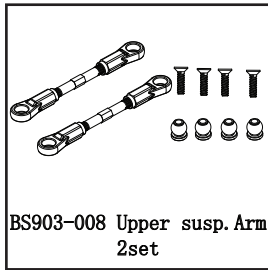

BS903-008 Upper susp. Arm 2set

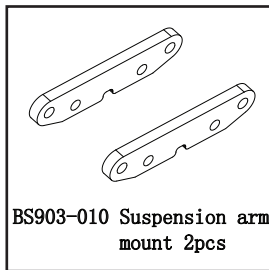

BS903-010 Suspension arm mount 2pcs

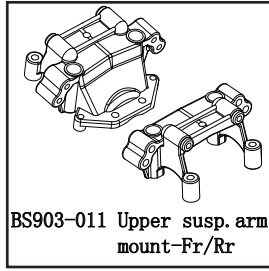

BS903-011 Upper susp. arm mount-Fr/Rr

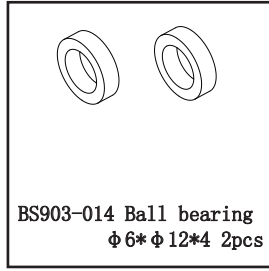

BS903-014 Ball bearing $\phi 6 * \phi 12 * 4$ 2pcs

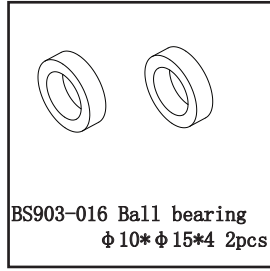

BS903-016 Ball bearing $\phi 10 * \phi 15 * 4$ 2pcs

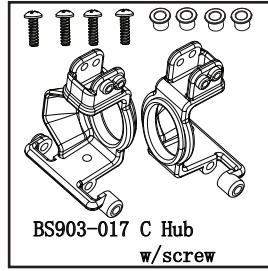

BS903-017 C Hub w/screw

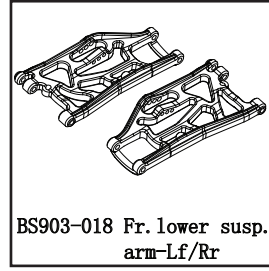

BS903-018 Fr. lower susp. arm-Lf/Rr

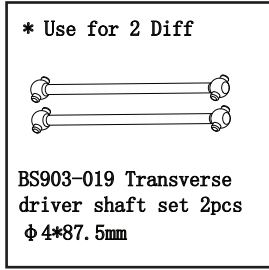

* Use for 2 Diff

BS903-019 Transverse driver shaft set 2pcs $\phi 4 * 87.5$ mm

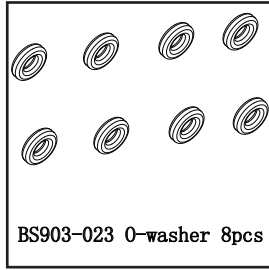

BS903-023 O-washer 8pcs

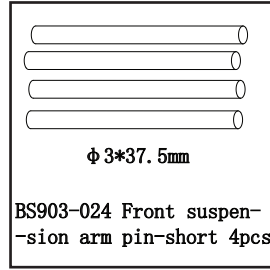

BS903-024 Front suspension arm pin-short 4pcs

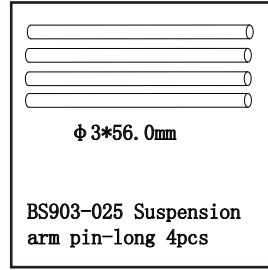

BS903-025 Suspension arm pin-long 4pcs

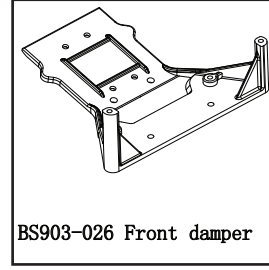

BS903-026 Front damper

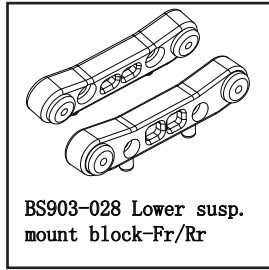

BS903-028 Lower susp. mount block-Fr/Rr

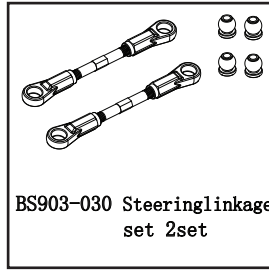

BS903-030 Steeringlinkage set 2set

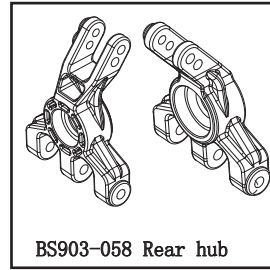

BS903-058 Rear hub

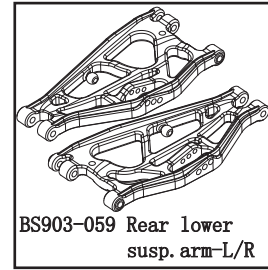

BS903-059 Rear lower susp. arm-L/R

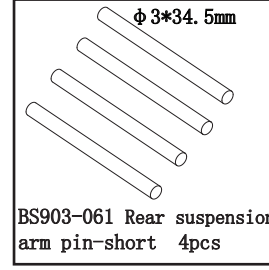

BS903-061 Rear suspension arm pin-short 4pcs

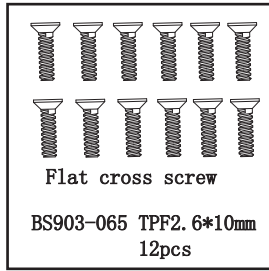

Flat cross screw

BS903-065 TPF2.6*10mm 12pcs

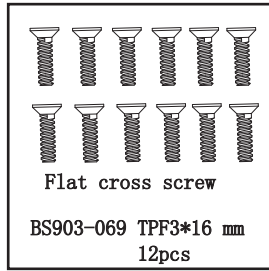

Flat cross screw

BS903-069 TPF3*16 mm 12pcs

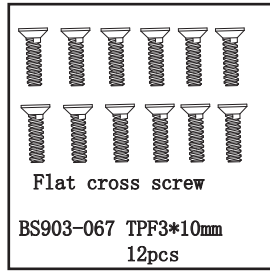

Flat cross screw

BS903-067 TPF3*10mm 12pcs

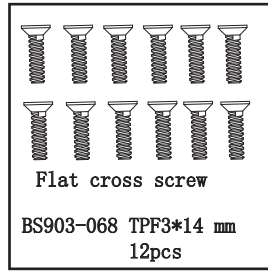

Flat cross screw

BS903-068 TPF3*14 mm 12pcs

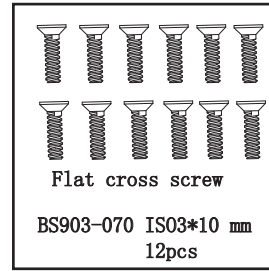

Flat cross screw

BS903-070 ISO3*10 mm 12pcs

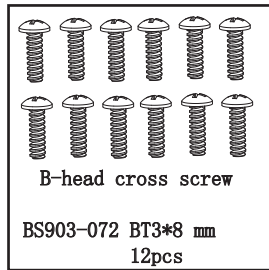

B-head cross screw

BS903-072 BT3*8 mm 12pcs

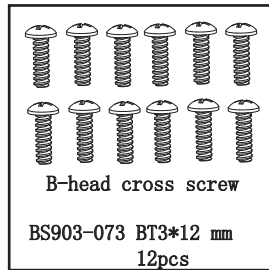

B-head cross screw

BS903-073 BT3*12 mm 12pcs

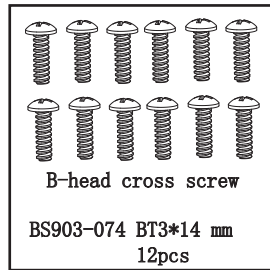

B-head cross screw

BS903-074 BT3*14 mm 12pcs

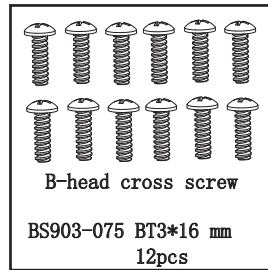

B-head cross screw

BS903-075 BT3*16 mm 12pcs

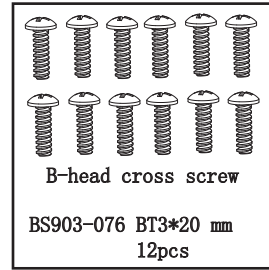

B-head cross screw

BS903-076 BT3*20 mm 12pcs

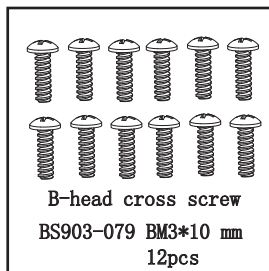

B-head cross screw

BS903-079 BM3*10 mm 12pcs

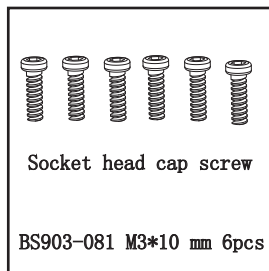

Socket head cap screw

BS903-081 M3*10 mm 6pcs

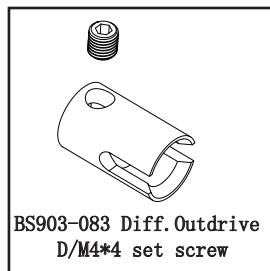

BS903-083 Diff.Outdrive D/M4*4 set screw

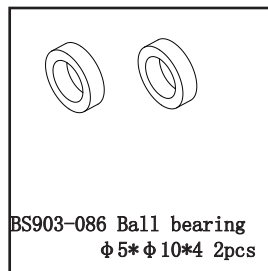

BS903-086 Ball bearing $\phi 5 * \phi 10 * 4$ 2pcs

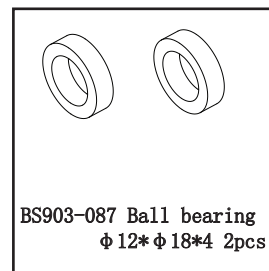

BS903-087 Ball bearing $\phi 12 * \phi 18 * 4$ 2pcs

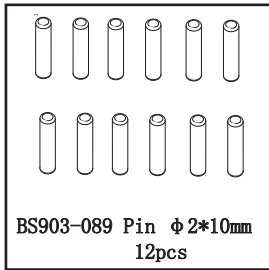

BS903-089 Pin $\phi 2*10\text{mm}$
12pcs

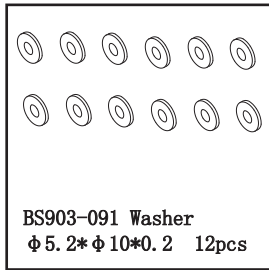

BS903-091 Washer
 $\phi 5.2*\phi 10*0.2$ 12pcs

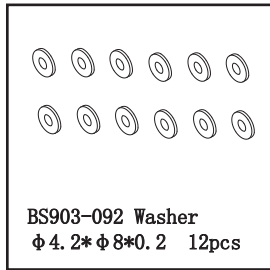

BS903-092 Washer
 $\phi 4.2*\phi 8*0.2$ 12pcs

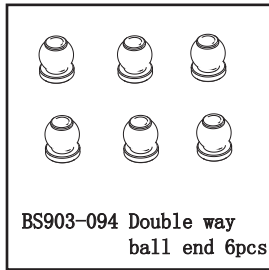

BS903-094 Double way
ball end 6pcs

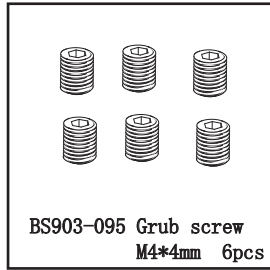

BS903-095 Grub screw
M4*4mm 6pcs

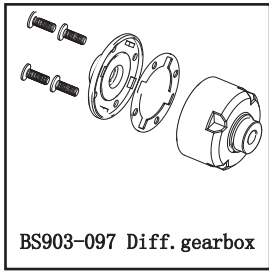

BS903-097 Diff. gearbox

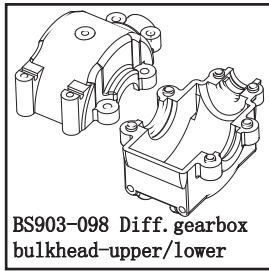

BS903-098 Diff. gearbox
bulkhead-upper/lower

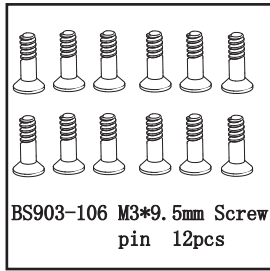

BS903-106 M3*9.5mm Screw
pin 12pcs

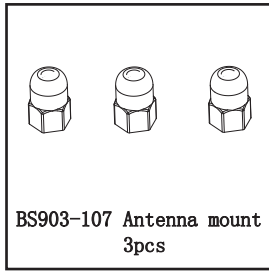

BS903-107 Antenna mount
3pcs

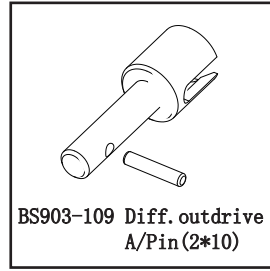

BS903-109 Diff. outdrive
A/Pin(2*10)

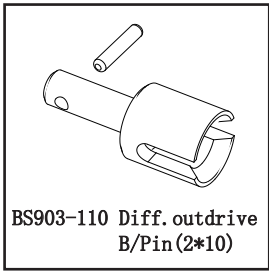

BS903-110 Diff. outdrive
B/Pin(2*10)

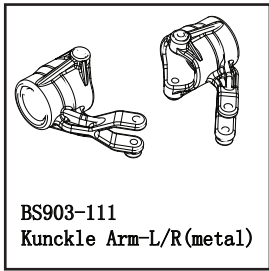

BS903-111
Kunckle Arm-L/R(metal)

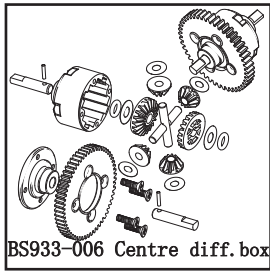

BS933-006 Centre diff. box

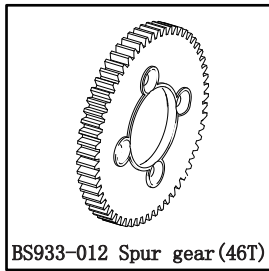

BS933-012 Spur gear (46T)

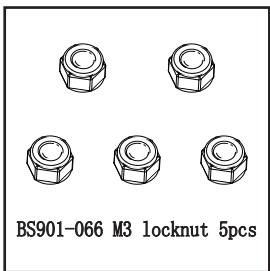

BS901-066 M3 locknut 5pcs

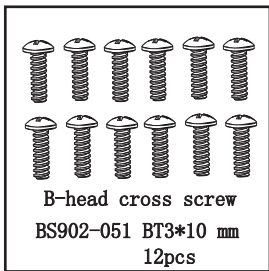

B-head cross screw
BS902-051 BT3*10 mm
12pcs



BS804-001 Tire unit 2pcs
BS804-001A Tire unit
(chromed) 2pcs

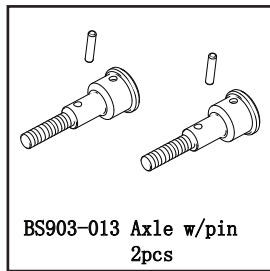

BS903-013 Axle w/pin
2pcs

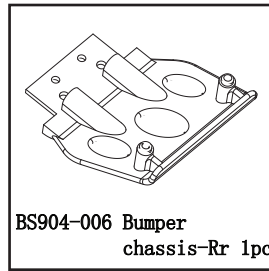

BS904-006 Bumper
chassis-Rr 1pc

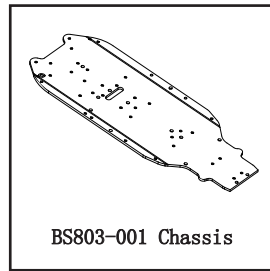

BS803-001 Chassis

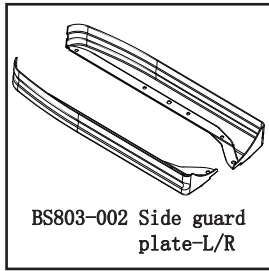

BS803-002 Side guard
plate-L/R

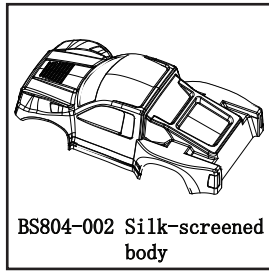

BS804-002 Silk-screened
body

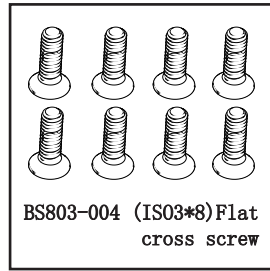

BS803-004 (IS03*8) Flat
cross screw

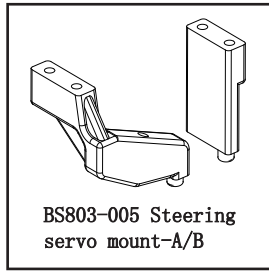

BS803-005 Steering
servo mount-A/B



BS803-036 Steering
servo horn linkage 1set

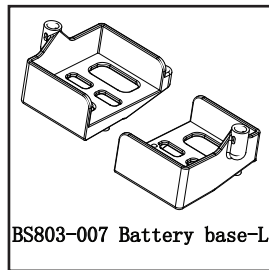

BS803-007 Battery base-L

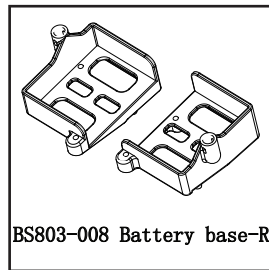

BS803-008 Battery base-R

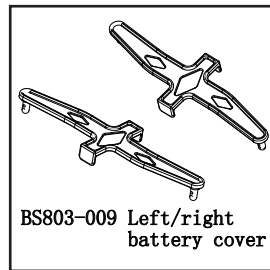

BS803-009 Left/right
battery cover

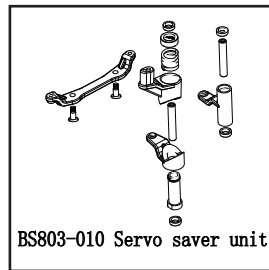

BS803-010 Servo saver unit

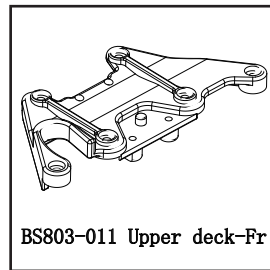

BS803-011 Upper deck-Fr

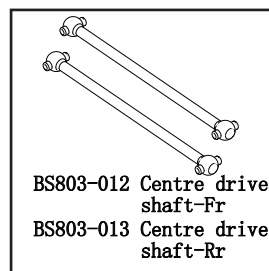

BS803-012 Centre drive
shaft-Fr
BS803-013 Centre drive
shaft-Rr

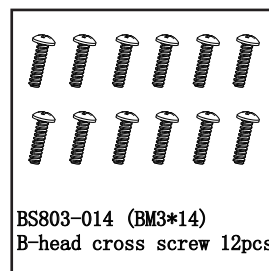

BS803-014 (BM3*14)
B-head cross screw 12pcs

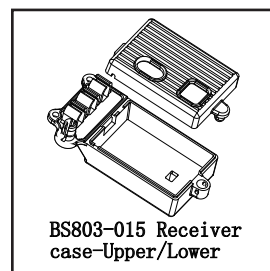

BS803-015 Receiver
case-Upper/Lower

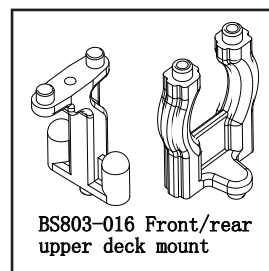

BS803-016 Front/rear
upper deck mount

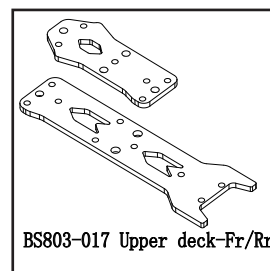

BS803-017 Upper deck-Fr/Rr

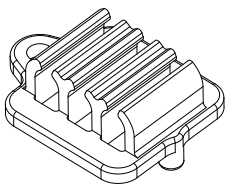

BS803-018 Wire mount

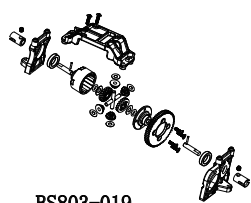

BS803-019
Centre diff. Unit

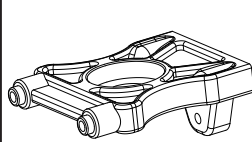

BS803-020
Centre diff mount

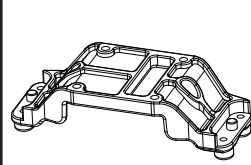

BS803-021
Centre Diff Cover

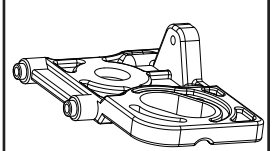

BS803-022 Motor mount

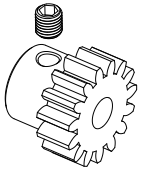

BS803-023 Motor gear
15T/M3 Grub screw

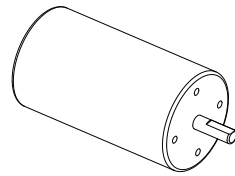

BS803-024 Brushless
motor KV:2230

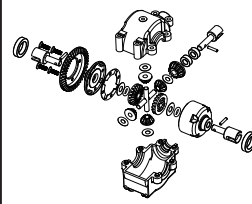

BS803-025
Diff. gearbox unit

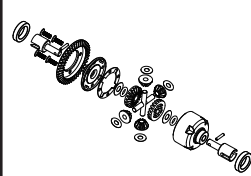

BS803-026 Diff. Unit

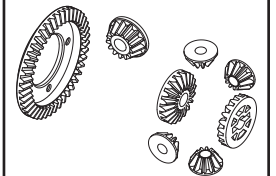

BS803-027 Driving/Driven
Gear, Diff. Gear/Bevel gears

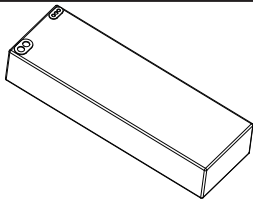

BS803-028 7.4V/20C
LiPo battery

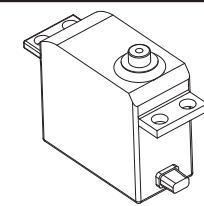

B7018W 9kg servo

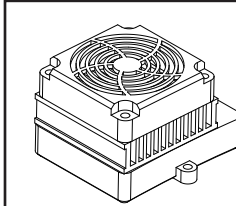

B7055W Brushless ESC 80A

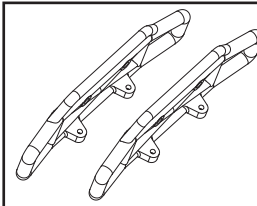

BS904-003 Bumper 2pcs

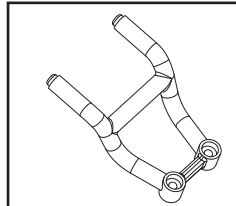

BS904-004 Bumper brace

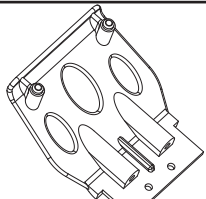

BS904-005 Bumper
chassis-Fr 1pc



B7055 transmitter complete



B7054W Receiver 1pcs

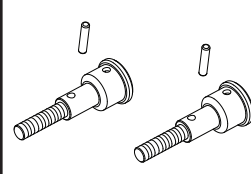

BS808-001 Axle w/pin
2pcs

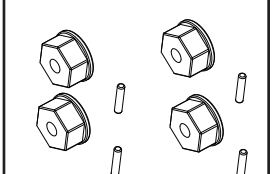

BS808-002 Rim hub w/pin
2*10 4pcs

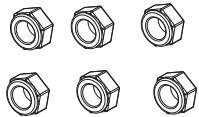

BS808-003 M5mm Nylon
lock-nut 6pcs

OPTIONAL PARTS/UPGRADE PARTS

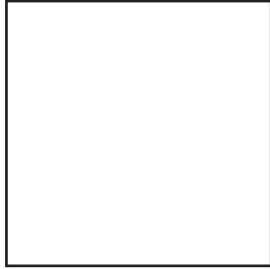
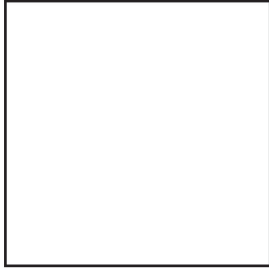
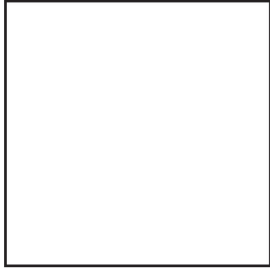
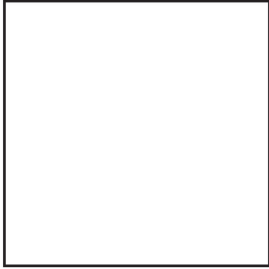
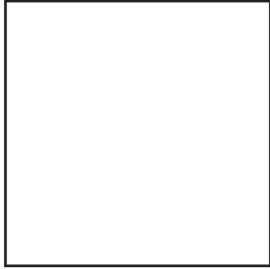
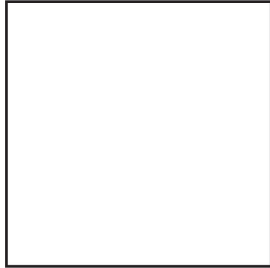
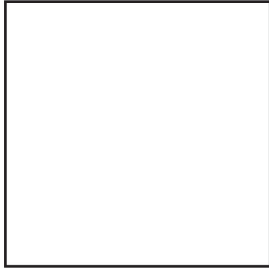
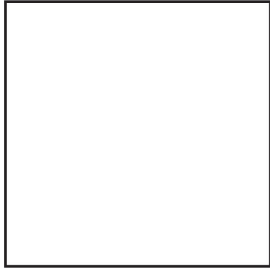
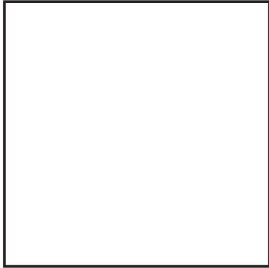
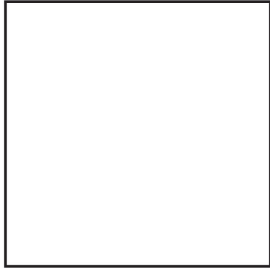
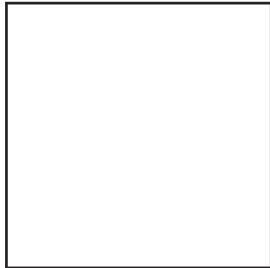
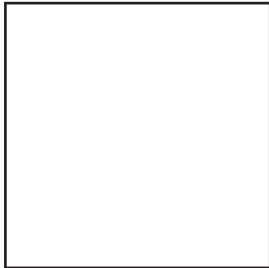
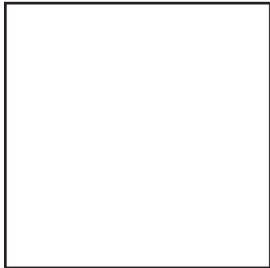
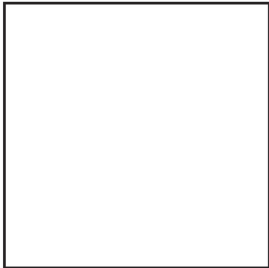
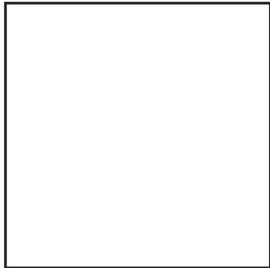
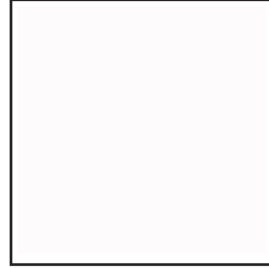
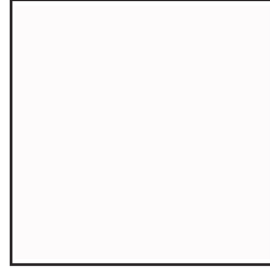
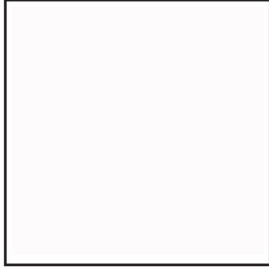
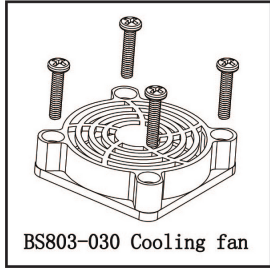
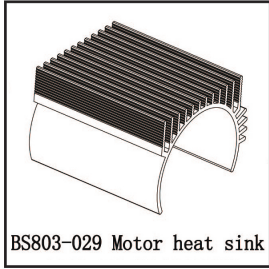
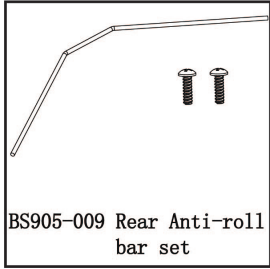

Precautions and Warnings for Use and Handling of Lithium Polymer Battery

Preface

In order to get the optimum performance and reliable safety, consumers shall read and take the following instructions and precautions when use and handle the Lithium Polymer (Li-Po) batteries.

1. Charging

1-1 Charging current should not be more than the maximum charge current specified in the Product Specification (normally 0.5C-1.0C or lower). Charging with higher current may damage the cell or even lead to safety problem, e.g. overheating or leakage.

1-2 Charging voltage shall not be more than that specified in the Product Specification (4.2V/cell). 4.25V is the maximum charging voltage for each cell. Never charge the battery in series and be sure that each single cell has a separated charging circuit with a max. charging voltage of 4.25V. Or the battery may be overcharged, and lead to fire or explosion. The user is fully responsible to the result of misusing the battery.

1-3 Charging temperature: The cell should be charged within the range of temperatures specified in the Product Specification. Stop charging immediately when the surface temperature of the battery is over 50°C.

1-4 Reverse charging: Please make sure the polarities of cells are connected properly before charging. Reverse charging is strictly prohibited. Reverse charging cannot charge the cells but will deteriorate their charging/discharging and safety characteristics, or even lead to fire or explosion.

2. Discharging

2-1 Discharging current: The cell shall be discharged at the current no more than the maximum discharging current specified in the Product Specification. Over current discharging may damage the battery and cause over-heat.

2-2 Operation temperature: Use the battery within the temperature range specified in the Product Specification. Stop using when temperature is over 70°C.

2-3 Over-discharging: Over-discharging will deteriorate the cell's performance and characteristics. Do not over-discharge a battery below 2.75V/cell.

3. Storage

If you intend to keep the battery for a long time (3 months or longer), it is strongly recommended that the battery shall be stored under the environment with temperature 10-25°C, low humidity and without corrosive gas. The battery should be charged every six months to ensure that each cell's storage voltage is 3.6~3.9V.

Others

>The aluminum packing foil is very soft that it will be easily left scratches. Please do not hit the cell with any sharp edge parts.

>Don't fall, hit or bend the battery. It may cause fire or explosion.

>Short circuit the battery is strictly prohibited, it may damage the battery seriously.

>Never disassemble the battery. It may cause fire.

>Never dispose of the battery in fire. It is very dangerous and strictly prohibited.

>To place the battery into liquid such as water is strictly prohibited.

>Always remove battery from car when charging. Charging the battery in a car is forbidden and is dangerous.

>Avoid vibration, shock or extruding the battery. Handle carefully when moving it.

Redcat Racing

<http://www.redcatracing.com>